

IPD-DM11

Hyper Wide Light Dynamic IP Network Dome Camera



FEATURES



Ikegami has been a world leader in analog camera technology for over half a century. The IPD line of network cameras represents the same quality and craftsmanship you have come to expect from the Ikegami in an Internet Protocol (IP) platform.

The IPD-DM11 combines the benefits of an IP network camera with our Hyper Wide Dynamic technology. The resulting sub-megapixel camera captures more useful information from a given scene than megapixel cameras with much greater bandwidth requirements.

IP network cameras produce images previously unimaginable with analog cameras, and allow for modern low-voltage integration at an unprecedented level. If there is one "Achilles heel" to traditional IP technology, it would be the challenge of uneven illumination (i.e. window areas, lobby entrances of buildings, or any location where intense bright and dark areas coincide). With the IPD-DM11 images are clear and natural, regardless of lighting conditions. The sub-megapixel camera delivers a perfect balance of resolution and bandwidth usage for video surveillance.



Conventional Model

IPD-DM11

Engineered Dome Camera

The low-profile The IPD-DM11 is designed to complement the surrounding architecture with its smooth lines and soft curves. The IPD-DM11 features 3 axis adjustment and is equipped from the factory with a choice of 2.8-10mm or 9-22mm varifocal lens to cover a full range of installations.

IP Network Camera

The IPD-DM11 is a full feature network camera with H.264/M-JPEG video compression support and standard power over Ethernet (PoE) capability. The IPD-DM11 is ONVIF compliant and fully integrated with a large number of network platforms.

More Usable Pixels

In a typical light-challenged security environment, a standard megapixel camera can lose a large number of pixels to illumination issues. The camera may collect 1,400,000 pixels from a given scene, but only 500,000 will be useful. The IPD-DM11 produces more usable pixels per image in difficult lighting conditions and does not waste bandwidth transmitting unusable pixels.

High-quality Picture

The camera is designed for smear-free imaging and low noise. The Digital Signal Processor enhances details producing crisp images with a high signal-to-noise ratio.

Scene File Function and Field Setup

The advanced internal menu of the IPD-DM11 allows for precision image adjustment. 4 preset scene files cover the most common lighting challenges and act as a baseline for quick setup. The IPD-DM11 features an analog BNC service port-delivering a true 520TVL image to a local monitor analog for simplified setup and service. No network connection is needed!

Hyper Wide Light Dynamic IP Network Dome Camera

IPD-DM11

SPECIFICATIONS

Image Sensor	1/3" DPS CMOS sensor		
Effective Pixels	Approx.410,000 pixels, Effective 758(H) x 540(V)		
Scanning System	NTSC : 525 lines at 59.94Hz, 2:1 interlace PAL : 625 lines at 50Hz, 2:1 interlace		
Synchronization System	Internal Crystal Lock		
Analog Video Output	VBS 1.0Vp-p/75Ω(for adjusting angle of view) Horizontal Resolution 520 TV Line or better		
S/N Ratio	50dB or better (p-p/rms)		
Minimum Illumination (AGC ON)	Type 31		Type 92
	In color mode : Electronic Sensitivity Up OFF		
	0.22lx/F1.2[50IRE]		0.35lx/F1.5[50IRE]
	In color mode : Electronic Sensitivity Up ON 32x		
	0.007lx/F1.2[50IRE]		0.017lx/F1.5[50IRE]
	In monochrome mode : Electronic Sensitivity Up OFF		
	0.022lx/F1.2[25IRE]		0.035lx/F1.5[25IRE]
Wide Dynamic Range	Built-in, and Variable		
	ON(AGC/HYPER-AGC) / OFF(LOW/MID/HIGH) selectable		
	Built-in, ON /OFF selectable(Up to 32 times)		
AGC (Automatic Gain Control)	Built-in, ON /OFF selectable(Up to 32 times)		
Electronic Sensitivity Up	Built-in, True Day/Night, Auto/Manual selectable		
Day/Night Function	Built-in (Up to 4 times)		
Digital Zoom	DC Iris		
Auto Iris Function	Built-in		
Detail Correction	ATW/ATWex/AWC/MANU selectable		
White Balance	Built-in, ON/OFF selectable (FFD Function)		
Flicker Reduction Function	Built-in (Maximum 8 zones)		
Privacy Masking	Built-in, ON/OFF selectable (DNR Function)		
Digital Noise Reduction	CRT/LCD selectable		
Monitor Output Selection	Up to 24characters (alphanumeric and symbols)		
Camera ID	Codec		
Image Compression	Image Size	H.264 / M-JPEG selectable	
	Image Size	NTSC : 720x480, 720x240, 352x480, 352x240 PAL : 720x576, 720x288, 352x576, 352x288	
	Frame Rate	NTSC : Up to 30fps PAL : Up to 25fps	
	Bit Rates(H.264)	64Kbps ~8Mbps	
	Image Set-up(M-JPEG)	5 steps	
	Transmission Mode	VBR/CBR	
	Audio Function	Built-in, AUDIO Input 1, AUDIO Output 1	
Network	Ethernet 10Base-T/100Base-TX		
Protocol	TCP, UDP, RTP/RTCP, RTSP, HTTP, FTP, NTP, ONVIF support (Multicast Delivery available.)		
Monitoring	Viewer or NVR		
Focus EZ	Built-in		
Built-in Lens	Type 31		Type 92
	Focal length	ƒ2.8 ~10mm	ƒ9 ~22mm
	Angle of View (Horizontal)	28.8° ~94.6°	13.0° ~30.6°
Power Requirement	DC12(10.5 ~15V)		
	PoE (IEEE 802.3af) CLASS 0		
Power Consumption	4W approx.		
Operating Ambient Temperature	-10°C ~+50°C		
Operating Ambient Humidity	30% ~90% RH (non-condensing)		
External Dimensions	Ø148 x H120mm (without projection)		
Weight	600g		
Input/ Output Connectors	LAN -- RJ-45(Auto-MDI/MDIX)		
	DC12V Input -- 2P		
	Service Monitor Out -- BNC		
	AUDIO Input -- Mini Jack		
	AUDIO Output -- Mini Jack		
Standard Accessories	Instruction Manual		

DIMENSIONS (Unit: mm)

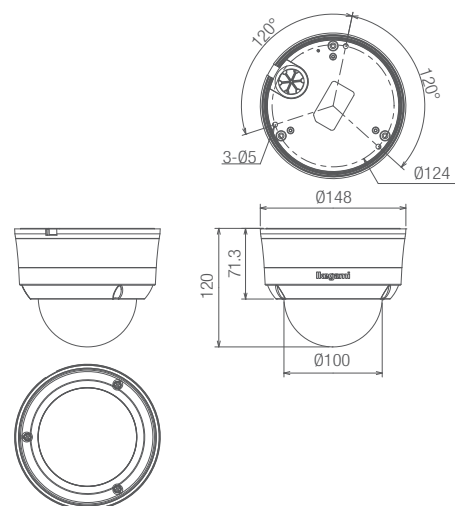

OPTIONAL ACCESSORIES

Wall Mount



■ XHG-1139

Pendant Mount



■ XHG-1119

Design and specifications are subject to change without notice.

Ikegami Tsushinki Co.,Ltd.

■ URL : <http://www.ikegami.co.jp/en/>

■ Head Office : 5-6-16 Ikegami, Ohta-ku, Tokyo 146-8567, Japan TEL.03-5700-1111 / FAX.03-5700-1137
 ■ Overseas Sales Division : 5-6-16 Ikegami, Ohta-ku, Tokyo 146-8567, Japan TEL.03-5700-4117 / FAX.03-5748-2200
 ■ Beijing Office : No.417 Jia Tai International Mansion, No. 41 East Fourth Ring Road, Chaoyang District, Beijing, China TEL.010-85711804 / FAX.010-85711804

Ikegami Electronics (U.S.A.), INC.

■ URL : <http://www.ikegami.com>

■ Headquarters : 37 BROOK AVENUE, MAYWOOD, NJ 07607 TEL.(201) 368-9171 / FAX.(201) 569-1626

Ikegami Electronics (Europe) GmbH ■ URL : <http://de.ikegami.co.jp>

■ Headquarters : Ikegami Strasse 1, D-41460 Neuss, Germany TEL.02131-1230 / FAX.02131-102820
 ■ U.K. Branch : Unit E1 Cologne Court, Brooklands Close, Windmill Road, Sunbury-on-Thames, Middlesex TW16 7EB, England TEL.01932-769700 / FAX.01932-769710

U273A135-IB



Certified JQA-0755 Certified JQA-EM3888

