

INSTRUCTION MANUAL

Network Camera

MODEL

IPD-BX11



OUTDOOR USE WARNING

WARNING – TO PREVENT FIRE OR ELECTRIC SHOCK, DO NOT EXPOSE THIS APPLIANCE TO RAIN OR MOISTURE.

The apparatus shall not be exposed to dripping or splashing and that no objects filled with liquids, such as vases, shall be placed on the apparatus.

Ikegami

Ikegami Tsushinki Co., Ltd.

Thank you for choosing this Ikegami Network Camera.

Please read this Instruction Manual carefully to keep your Ikegami camera at peak performance for longer service period.

This unit is a cube-type 1 CMOS Network Camera and making use of a 1/3" type digital pixel sensor system (DPS).

This Ikegami product is made of ECO friendly components based upon the Company policy and corporate social responsibility to contribute towards the Global Environmental Solution for energy conservation and environmental sustainability, all the components used in this product are Non-hazardous, Toxic Free, Non-Lead and conform with Japan's Green Product regulation, EU's RoHS directive and other Environmental and hazardous chemical substances related regulations and laws.

Contents

	Page
1. Introduction	1
1-1. Handling precautions	1
1-2. Disclaimer	1
1-3. Protection of personal information	1
1-4. Cautions Concerning Network Connections	2
1-5. Limitations on Equipment Use	2
1-6. License for third party software.....	3
2. General	4
3. Features	5
4. Name of each section and its function	6
5. Operating Procedure.....	9
5-1. User Setup.....	9
6. Warranty and after-sale service	19
7. Specifications.....	20
8. External Appearance	22
9. Setup Flow Chart.....	23



The exclamation point within an equilateral triangle is intended to alert the user to the presence of important operating and maintenance (servicing) instructions in the literature accompanying the appliance.

NOTE:

This equipment has been tested and found to comply with the limits for a Class A digital device, pursuant to part 15 of the FCC Rules. These limits are designed to provide reasonable protection against harmful interference when the equipment is operated in a commercial environment. This equipment generates, uses, and can radiate radio frequency energy and, if not installed and used in accordance with the instruction manual, may cause harmful interference to radio communications. Operation of this equipment in a residential area is likely to cause harmful interference in which case the user will be required to correct the interference at his own expense.

CAUTION;

ANY CHANGES OR MODIFICATIONS NOT EXPRESSLY APPROVED BY THE PART RESPONSIBLE FOR COMPLIANCE COULD VOID THE USERS AUTHORITY TO OPERATE THE EQUIPMENT.

Instructions for Disposal of Electrical and Electronic Equipment in Private Households



**Disposal of used Electric and Electronic Equipment
(Applicable in the European Union and other European countries with separated waste disposal and collection methods)**

This symbol on the product, or in the related documents in the package, indicates that this product shall not be treated as normal household waste.

Instead, it should be taken to a proper applicable collection point or depot for the recycling of electric and electronic equipment.

By ensuring this product is disposed of correctly, you will help prevent possible negative consequences for the environment and human health, which could otherwise be caused by inappropriate waste handling of this product. The recycling of materials will help to conserve natural resources.

For more detailed information about recycling of this product, please contact your local city authority, your household waste disposal service or the place where you purchased the product.

IMPORTANT SAFETY INSTRUCTIONS

- 1) Read these instructions.
- 2) Keep these instructions.
- 3) Heed all warnings.
- 4) Follow all instructions.
- 5) Do not use this apparatus near water.
- 6) Clean only with a dry cloth.
- 7) Do not block any of the ventilation openings. Install in accordance with the manufacturer's instructions.
- 8) Do not install near any heat sources such as radiators, heat registers, stoves, or other apparatus (including amplifiers) that produce heat.
- 9) Do not defeat the safety purpose of the polarized or grounding type plug. A polarized plug has two blades with one wider than the other. A grounding type plug has two blades and a third grounding prong. The wide blade or the third prong is provided for your safety. When the provided plug does not fit into your outlet, consult an electrician for replacement of the obsolete outlet.
- 10) Protect the power cord from being walked on or pinched particularly at plugs, convenience receptacles, and the point where they exit from the apparatus.
- 11) Only use the attachments/accessories specified by the manufacturer.
- 12) Use only with a cart, stand, tripod, bracket, or table specified by the manufacturer, or sold with the apparatus. When a cart is used, use caution when moving the cart/apparatus combination to avoid injury from tip-over.



- 13) Unplug this apparatus during lightning storms or when unused for long periods of time.

- 14) Refer all servicing to qualified service personnel. Servicing is required when the apparatus has been damaged in any way, such as power supply cord or plug is damaged, liquid has been spilled or objects have fallen into the apparatus, the apparatus has been exposed to rain or moisture, does not operate normally, or has been dropped.
- 15) CAUTION - These servicing instructions are for use by qualified service personnel only. To reduce the risk of electric shock, do not perform any servicing other than that contained in the operating instructions unless you are qualified to do so.

CAUTION

Danger of explosion if battery is incorrectly replaced.
Replace only with the same or equivalent type.

1. Introduction

1-1. Handling precautions

- Do not expose the internal mechanism of the camera in a water-splashed or highly humid environment.
- Do not use the camera where the ambient temperature drops below -10°C or rises above +50°C. The images and component parts may be adversely affected or the camera may not function correctly.
- Do not open the case of the camera, unless it is absolutely necessary for setup or installation because there are precision electrical and electronic components inside and accident may result.
- Be sure to turn off the power before installing or making connections.
- Be careful not to drop or give a strong shock to the camera while transporting it.
- Do not touch the image sensor
- Do not orientate the camera directly towards the sun.
- Because of the digital image device characteristics, images may look unnatural at high temperatures, this does not mean the camera is faulty.

1-2. Disclaimer

- (1) This equipment is used to take images as a surveillance camera. It is not to be used for the purpose of crime prevention.
- (2) Ikegami assumes no responsibility for the following matters.
 - ① System impediment, malfunction or breakdown as a result of connecting with equipment from other companies.
 - ② Accidents or breakdowns due to mistaken usage or negligence.
 - ③ Disassembly or repair of equipment that is not recognized by Ikegami.
 - ④ Improper use by a third party of the surveillance images produced by this equipment, or damages resulting from such use.
 - ⑤ Loss of the setting contents.
 - ⑥ In addition, all damages resulting directly or indirectly in connection with this device.

1-3. Protection of personal information

If it is possible to identify individuals with the image information obtained with this device, this amounts to personal information as determined in the Act on the Protection of Personal Information. Image information of this sort should be handled properly in accordance with the law.

The contents of information recorded on the SD memory card used with this device may correspond in some cases to private information. If this device is given to a third party due to disposal, transfer or repairs, please be especially careful about handling.

1-4. Cautions Concerning Network Connections

This equipment is connected to a network for use. To protect the system from damage unique to network connections, the customer should act on personal responsibility to carry out security measures.

Damage unique to networks includes leaking/outflow of information obtained with this device, damages due to illegal access and system stoppage.

Countermeasures include the following. The customer should additionally take personal responsibility to insure sufficient countermeasures.

- Do not install in locations where cables can be easily exchanged.
- Insure network security (firewalls, etc.)
- Carry out periodic virus checks on computers connected to the system.
- Computers connected to the system should have limitations on users (password setting).
- The system should be managed to insure that there is no leaking of authentication information.

1-5. Limitations on Equipment Use

This equipment has its usage regulated by the **VC-1 and AVC/H.264 Patent Portfolio Licenses Concerning Personal and Non-Commercial Use**. This license should be observed in limiting use of this equipment to private use or uses that are non-profit.

For details consult the following:

<http://www.mpegla.com>

Reference: Actions permitted by VC-1 and AVC/H.264 images for private and non-commercial uses.

- (1) Only encoding of images to the VC-1 and AVC/H.264 for private uses or uses not having profit for purposes.
- (2) To be used for encoding for private applications or applicant that do not have profit as a goal, and for decoding of VC-1 and AVC/H.264 images from a supplier who has obtained a patent.

1-6. License for third party software

We are licensed to use the software made by third parties for this product. The license for each software shall be applicable to the software in question respectively and not to the whole software of this product.

Certain software used in this product and made by third parties are used based on the following licenses:

- * GNU General Public License Version 2 (GPL)

<http://www.gnu.org/licenses/old-licenses/gpl-2.0.html>

- * GNU Lesser General Public License Version 2.1 (LGPL)

<http://www.gnu.org/licenses/old-licenses/lgpl-2.1.html>

- * OpenSSL License

<http://www.openssl.org/source/license.html>

This product includes software developed by the OpenSSL Project for use in the OpenSSL Toolkit. (<http://www.openssl.org/>)

- * Original SSLeay License

<http://www.openssl.org/source/license.html>

This product includes cryptographic software written by Eric Young (eay@cryptsoft.com)

- * GoAhead License

<http://embedthis.com/products/goahead/>

The text of the license is included in the Instruction manual (Application Instructions).

Distribution of source code of free software

If you would like to purchase the GPL/LGPL software used in this product, please contact our sales division. In accordance with the licence terms, we will provide this at cost.

2. General

This Network camera is provided with a 1/3-inch DPS CMOS sensor. The CCTV camera features wide dynamic range, high sensitivity and high resolution, and is equipped with the color/black-and-white switching, back-light compensation, automatic iris control, line lock and other functions. The unit is best suited for general surveillance.

3. Features

- (1) Hyper Wide Light Dynamic Range (Hyper WDR)
The WDR function provides for very effective compensation of high light and dark areas in screen. This situation may occur generally outside or viewing from indoor to outdoor scenes. Even in large light fluctuations, bright-and-dark subjects can be captured and viewed clearly with a natural appearance.
- (2) Small-size cube shape
The small-size cube shape of the camera allows it to be most suitable to be installed into various devices such as ATM units.
- (3) High-quality picture and high resolution
The camera is designed for smear-free imaging and low noise. The well-designed DSP, Digital Signal Processor, effectively enhances details, which achieves crisp and sharp images with a high signal-to-noise ratio.
- (4) Automatic white balance
Thanks to the automatic follow-up white balance control (ATW), the white balance adjusts itself no matter how great the subject's color temperature fluctuates.
- (5) Automatic Sensitivity Control
In conjunction with the wide dynamic control by the multi-sampling system, the camera incorporates the automatic sensitivity control function that always provides adequate and bright images even through its fixed-iris lens.
- (6) Scene File
In addition to normal setting (NORMAL), there are four patterns for scene files (setting files) that are preset beforehand to a particular scene. By selecting those patterns, it is easy to carry out image setting suited to the scene without having to carry out specialized image adjustment.

4. Name of each section and its function

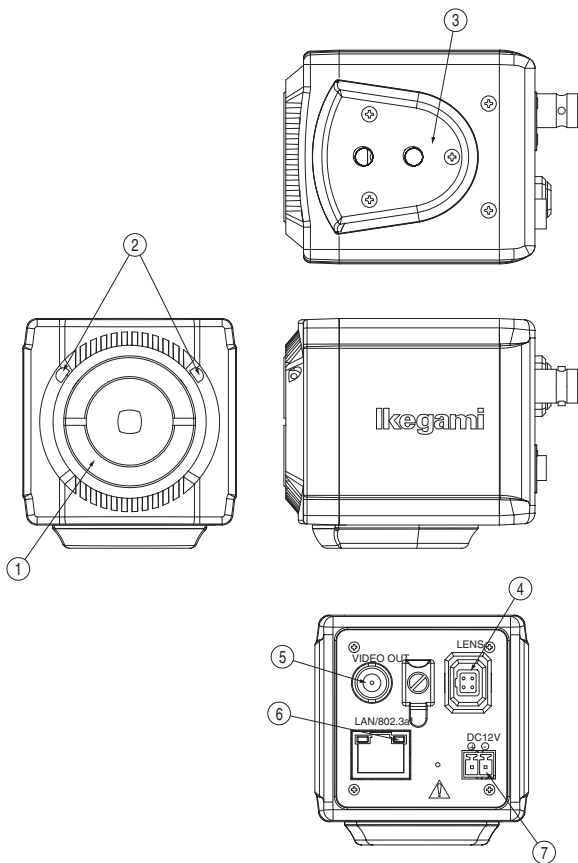

- ① Lens mount (CS mount)
This is used to mount the lens on the camera. Many types of CS mount lens can be attached.
- ② Back focus lock screw
After completing the flange back adjustment of the camera, use the supplied Allen wrench to tighten the screw until it is fully fixed.
- ③ Holder mounting screw holes
These holes are used to install and fix the camera on the camera mounting or bracket. They can be also applicable to general use tripods which have a quarter inch thread.

Note

To use these holes to attach the camera on a tripod or other mount, make sure you use suitable size mounting bolts as follows (1/4" -20UNC), they should not be longer than 5.5 mm to avoid an un-stable installation.

- ④ Auto iris lens connector
Specifically used to connect the auto iris lens.
Applicable connector: E4-191J-100 or equivalent

● DC Iris System

— Connector cable leads —

- 1. Damping coil (-)
- 2. Damping coil (+)
- 3. Driving coil (+)
- 4. Driving coil (-)

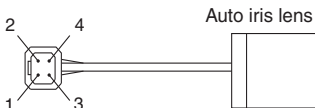

* Connect the leads as shown above.

Please refer also to the instructions of the lens to be used.

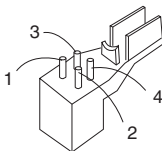

Connector pin assignment

- ⑤ Video output terminal (VIDEO OUT)
To be used to give out the video signal. Connect this to the video input terminal of a monitor, switcher etc. (To be terminated with 75-ohm impedance.)
- ⑥ Power indicator (POWER)
The LED indicator stays on in green while the camera power is on.

⑦ DC12V power input terminal
Keep the input power at DC10.5-15.0 V.

* This installation should be made by a qualified service person and should conform to all local codes.

5. Operating Procedure

5-1. User Setup

This camera is provided with user setup function for picture quality, and camera ID. In order to set up, use coaxial multiple controller (optional). The setup menu is a tree type on-screen-display.

When installing the camera it is possible to set up the various functions.

5-1-1. SETUP MENU 1/4

* New settings can be saved, if EXIT is selected to quit the menu.

SETUP MENU		
→PAGE		1/4
SCENE		NORMAL
DAY/NIGHT		AUTO ↓
SENS UP		ON
LIGHT CONTROL ↓		
GAIN		AGC ↓
WHITE BALANCE		ATW
EXIT	CANCEL	RESET

(1) PAGE

Possible to change pages.

(2) SCENE

Possible to easily set the image quality to fit the photography environment without making fine settings of the picture quality.

- ① NORMAL: This is a standard image quality setting that can be used for almost all photographic subjects.
- ② INDOOR1: Suited to indoor photography.
- ③ INDOOR2: Suited to reverse light indoors.
- ④ OUTDOOR1: Suited to outdoor photography.
- ⑤ OUTDOOR2: Suited to reverse light outdoors.

* Is not always suited to all photography environments. Depending on the photography environment, carry out adjustment of the picture quality without selecting SCENE. When the Menu concerned with picture quality changes from the initial setting value, unit goes to CUSTOM.

(3) DAY/NIGHT

Possible to switch between day and night.

- ① AUTO: Automatic switching is made: high-quality color images during the day, and high-sensitivity monochrome pictures at night. Press the E button, and the screen at right shows up.

- **SWITCHED LEVEL:**

The brightness level for switching to the day or night mode can be preset. The levels can be selected in the order of BRIGHT, MID and DARK.

- ② **COLOR:** The color mode can be selected.
- ③ **B/W:** The Monochrome (B/W) mode can be selected.

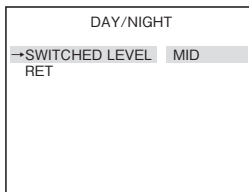

(4) **SENS UP**

Selection of electronic sensitivity increase mode. Possible to choose electronic sensitivity increase rate.

- ① **OFF:** Electronic sensitivity increase mode is OFF.
 - ② **ON:** Possible to set the maximum magnification during operation of electronic sensitivity increase.
- **SLOW SHUTTER:** x2, x4, x8, x16, x32

The higher the factor, the higher the sensitivity, but motions at maximum factor look unnatural.

(5) **LIGHT CONTROL**

The backlight compensation and sensing spot area modes can be selected. The wide dynamic level and DC type iris lens are adjusted.

Select LIGHT CONTROL on the main menu screen. Press the E button, and the screen at right shows up.

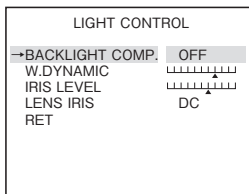

① **BACKLIGHT CMP.:**

The backlight compensation modes can be selected.

- **ON:** Normal backlight compensation mode is in effect.
- **1SPOT:** Select 1SPOT and press the E button, and the screen shown at right appears. Highlight ADJUST

ZONE and press the E button, and the BLC compensation sensing area setting screen comes up.

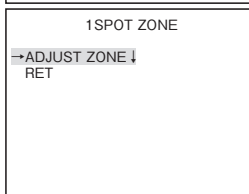

Each time the E button is pressed, the assigned area color changes in turn Blue, Green and Red in this order.

- In case of Blue:
 - Using the U, D, L or R button, the field can be moved wherever you like.
- In case of Green:
 - Using the U, D, L or R button, the field can be enlarged.

- In case of Red
Using the U, D, L or R button, the field can be reduced.
- To quit the field setting screen, hold down the E button longer than 2 seconds.
Once the 1SPOT ZONE screen appears, select RET and press the E button. The previous menu shows up.
- 2SPOT: As with the 1SPOT mode, two sensing areas can be preset. Take the same procedure as for the 1SPOT mode.
- OFF: The backlight compensation is off.
- ② W.DINAMIC: The hyper wide dynamic level can be varied. Adjust the marker while watching an actual scene to have an optimum result.
- ③ IRIS LEVEL: Adjust the diaphragm.
Move the marker to the right, and the lens opens (Brightness enhanced).
Adjust the marker while watching an actual scene to have an optimum result.
- ④ LENS IRIS: Select according to the type of lens used.
 - DC: Select when using an auto-iris lens.
 - MANUAL: Select when using an manual lens.

(6) GAIN

The gain control modes can be selected.

- ① AGC: This is an automatic sensitivity adjustment mode.
Select AGC and press the E button, and maximum gain setting can be achieved. To suppress the noise lower than at the HIGH (initial) setting, select MID or LOW.
- ② HYP-AGC: This mode is higher in sensitivity than AGC. But images may look rugged at higher sensitivities.
- ③ LOW: This fixed-gain mode keeps the sensitivity low for brighter spots.
- ④ MID: This fixed-gain mode keeps the sensitivity middle between HIGH and LOW.
- ⑤ HIGH: The fixed-gain mode keeps the sensitivity high for darker spots.

(7) WHITE BALANCE

The white balance mode can be selected. The manual white balance settings are also made.

- ① ATW: White balance is automatically changed to full time auto-tracking.
- ② ATW Ex: White balance is automatically changed to full time auto-tracking, but the covering area of color temperature range gets higher than the ATW mode.
Compared with the ATW mode, an accuracy of white tracking is not very good in this mode, but in certain conditions this may powerful to compensate color differences.

③ AWC: This is the so-called one-push automatic white balance control. Shoot a target white subject and press the E button, and the white balance will be adjusted.

④ MANUAL: Adjust manually
Select MANUAL, press the E button and the screen at left appears on screen.
R GAIN is used to adjust the reddish color. B GAIN is used to adjust the bluish color.

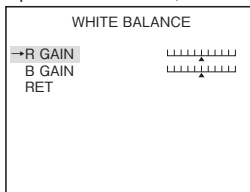

- (8) EXIT
Used to save the settings and to quit the menu.
- (9) CANCEL
Used to return the settings to the previously saved ones.
- (10) RESET
Used to return the settings to the factory ones.

5-1-2. SETUP MENU 2/4

* New settings can be saved, if EXIT is selected to quit the menu.

SETUP MENU	
→PAGE	2/4
CHROMA	██████████
DETAIL	██████████
PEDESTAL	7.5 IRE
VIDEO LEV.	██████████
DNR	OFF
CRR	OFF
EXIT	CANCEL
	RESET

- (1) PAGE
Possible to change pages.
- (2) CHROMA
Possible to adjust chroma level. Adjust while viewing the screen.
- (3) DETAIL
Possible to adjust details. Adjust while viewing the screen.
- (4) PEDESTAL
Possible to choose pedestal level.
- (5) VIDEO LEV.
Possible to adjust video level. Adjust while viewing the screen.
- (6) DNR (Digital Noise Reduction)
The noise reduction function can be switched on or off.
When DNR is ON, the SENS UP is set ON forcibly.
- (7) CRR
Possible to switch CRR (color-rolling restrain) function on and off.
① OFF: CRR (color-rolling restrain) function is OFF
② ON: CRR (color-rolling restrain) function in operation.
- (8) EXIT
Used to save the settings and to quit the menu.
- (9) CANCEL
Used to return the settings to the previously saved ones.
- (10) RESET
Used to return the settings to the factory ones.

5-1-3. SETUP MENU 3/4

* New settings can be saved, if EXIT is selected to quit the menu.

SETUP MENU		
→PAGE		3/4
CAMERA ID		OFF
VIDEO FLIP		OFF
PRIVACY MASK ↓		
DIGITAL ZOOM ↓		
VIDEO MODE		NORMAL
PROGRES. SCAN		OFF
EXIT	CANCEL	RESET

(1) PAGE

Possible to change pages.

(2) CAMERA ID

Up to 24 characters can be displayed on screen.

① OFF: No screen display.

② ON: Screen display.

● ID characters setting

Keep CAMERA ID highlighted and press the E button. The screen at right shows up.

- ID: Press the E button on ID, and the cursor appears. With the L or R button, select a character. Press the E button to save it, and the character box advances to the next one. To delete a character, press the E button to go through the code and place the cursor in the character to delete. Press the L or R button to get the box blank.
- ID ALL CLEAR: Highlight this item and press the E button. The ID code is cleared.
- ID POSITION: Highlight this item and press the L or R button. In this way, the ID code can be positioned up or down.

* Note: If the camera ID is displayed on the same line as the privacy mask, the mask becomes transparent. Set so that the camera ID and mask do not overlap.

ID EDIT	
→ID	
ID ALL ERASE	
ID POSITION	TOP
RET	

(3) VIDEO FLIP

Set Video Flip

① OFF: No video flip.

② HORIZ: Flips the image to right or left.

③ VERT: Flips the image up or down.

④ BOTH: Flips the image up and down or right and left.

(4) PRIVACY MASK

Possible to set up to 8 privacy masks.

Move to the Privacy Mask item and press the E button to display screen to the right.

PRIVACY MASK SETUP	
→PRIVACY MASK	OFF
PAINT	GRAY
RET	

* Note: If the camera ID is displayed on the same line as the privacy mask, the mask becomes transparent. Set so that the camera ID and mask do not overlap.

With this screen, make On or Off of the privacy masking and desired color of masking with PAINT, in three colors, Grey, Black or White.

While the privacy masking ON and push E button, an individual setup screen comes out.

ENABLE MASKS	
→MASK 1	ON ↓
MASK 2	ON ↓
MASK 3	OFF
MASK 4	OFF
MASK 5	OFF
MASK 6	OFF
MASK 7	OFF
MASK 8	OFF
RET	

With this screen, eight (8) different individual masking can be set.

It is possible to press the E button and set the mask position and size for the mask of the numbers set to ON.

● Mask setting procedure

- ① Move the blue semitransparent cursor to the above left of the location you wish to mask and press the E button. (If other masks are ON, the masks other than the one being set are displayed as grey semitransparent).
- ② When the cursor changes to blue, use the U, D, R, L buttons to adjust the size.

Each button is for;

- U : Moves a mask bottom line to above (Shrink height)
- D : Moves a mask bottom line to below (Enlarge height)
- R : Moves a mask bottom line to below (Enlarge height)
- L : Moves a mask bottom line to below (Enlarge height)

- ③ Press the E button to display the mask section as blue semitransparent.

If you want to change the mask position, push E button and change the screen to a translucent sky blue screen.

If you want to change the mask size, push E button and change the screen to a translucent blue screen.

When multiple mask displays are ON, each time the E button is pressed for a mask whose display is ON, the selection condition changes in the following order (masks whose display is OFF are skipped).

Mask1 Sky blue → Mask1 blue → Mask2 Sky blue → Mask2 blue →
Mask3 Sky blue → Mask3 blue → Mask4 Sky blue and so on.

- ④ Hold E button more than 2 seconds, the screen changes to the Privacy Mask Setting. This process shall be made after finishing mask setting.

(5) DIGITAL ZOOM

Set the zoom.

- ① ZOOM: Possible to choose among OFF, 2 magnification, 4 magnification and 8 magnification
- ② PAN: Move the zoom range to the right or left. Adjust to the desired position while viewing the screen.
- ③ TILT: Move the zoom range up or down. Adjust to the desired position while viewing the screen.

(6) VIDEO MODE

Set the resolution.

- ① NORMAL: This sets the camera to the normal resolution.
- ② HI-RES: This sets the camera to the high resolution.
* If HI-RES is selected, the screen may appear to be reduced to a smaller size. This is not a malfunction.
- ③ 16:9: Changed aspect ratio from 4:3 to 16:9.
* Please use a monitor which able to display 16:9.

(7) PROGRES.SCAN

This switches ON or OFF of the progressive scan.

(8) EXIT

Used to save the settings and to quit the menu.

(9) CANCEL

Used to return the settings to the previously saved ones.

(10) RESET

Used to return the settings to the factory ones.

5-1-4. SETUP MENU 4/4

* New settings can be saved, if EXIT is selected to quit the menu.

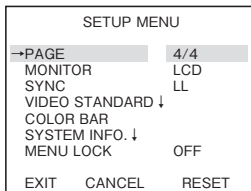

(1) PAGE

Possible to change pages.

(2) MONITOR

The optimum picture quality can be selected according to the monitor used.

① CRT: To be used when the camera is connected with a CRT (cathode ray tube) monitor.

(3) SYNC

The Sync systems, AC line Lock, internal Lock or Gen-lock mode are selected.

① INT: The internal sync mode is selected.

* This camera use INT mode.

(4) VIDEO STANDARD

This changes video standard between NTSC and PAL.

After selecting this video standard and push E button, then the following warning message will appear on a screen.

① CANCEL: goes back to the Setup Menu screen.

② OK: Selection screen will appear, as shown right.

NTSC or PAL can be selected.

* Ever time changing the standard, all the parameters of video related items goes back to the factory setting position

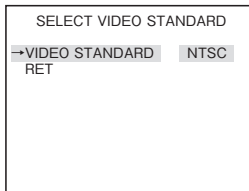
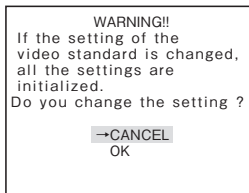

***Note** : Select the video signal method according to your TV system. If the wrong selection is made, the image may be distorted or not displayed. This does not indicate a malfunction.

(5) COLOR BAR

Press the E buttons to get the color displayed. Press the E button again to go back to the Setup Menu screen.

(6) MENU LOCK

The menu lock function protects saved settings against accidental modifications.

① To Lock

Get the saved settings locked with the L and R buttons to ON.

② Operation

When locked, EXIT alone is effective and all the other actions are invalid.

③ Unlocking

Press the button in the order U → R → D → L → U → D → E in the set-up mode.

If a wrong button is pressed halfway, start all over again.

(7) EXIT

Used to save the settings and to quit the menu.

(8) CANCEL

Used to return the settings to the previously saved ones.

(9) RESET

Used to return the settings to the factory ones.

6. Warranty and after-sale service

A warranty accompanies this product. Read and fill out the warranty card that you have received at your dealer. Keep this card in a safe place.

- Please consult Ikegami Electronics (U.S.A.) Inc. or Ikegami Electronics (Europe) GmbH or your dealer for full warranty information. Your dealer will repair or replace free of charge within the warranty period according to the warranty coverage.
 - For repairs after the expiration of the warranty period, consult your dealer or sales representative. It will first be judged whether the fault is repairable or not. Charged servicing will then be made upon request of the user.
 - Before you ask for servicing, please ensure you read the Instruction Manual. If the unit still fails, take note of the model number, date of purchase, problem, etc. in detail, and inform your dealer or sales representative.
 - If you have questions about the after-sale service, contact your dealer or sales representative.
- * We suggest you ask for preventive inspection as soon as possible.

7. Specifications

- | | |
|--|--|
| (1) Image Sensor: | 1/3-inch Pixim DPS CMOS sensor |
| (2) Pixel Number: | Approx. 410,000 pixels, 758 (H) x 540 (V) |
| (3) Scanning system: | NTCS: 525 TV lines / 59.94Hz , 2 : 1 interlace |
| (4) Sync system: | Internal synchronization: Crystal-lock |
| (5) Analog video output: | VBS 1.0Vp-p/75 ohms |
| (6) Resolution: | Horizontal; 520 TV lines |
| (7) S/N ratio: | Over 50dB (p-p/rms) |
| (8) Minimum subject illuminance: | |
| (Color) | 0.22Lx/F1.2 (electron sensitizing OFF, VBS output 50%)
0.007Lx/F1.2 (electron sensitizing 32, VBS output 50%) |
| (BW) | 0.022Lx/F1.2 (electron sensitizing OFF, VBS output 25%)
0.0007Lx/F1.2 (electron sensitizing 32, VBS output 25%) |
| (9) Wide Dynamic Range: | Built-in |
| (10) AGC: | ON (AGC, HYPER-AGC)/OFF (LOW, MID, HIGH) switching possible |
| (11) Electronic Sensitivity Control: | Built-in, On or Off Selectable Maximum 32 times |
| (12) Day-night switching: | True Day/Night, auto/manual switching possible |
| (13) Digital zoom function: | Included (max. 4 power) |
| (14) Auto iris function: | Compatible with DC iris |
| (15) DETAILED correction: | Built-in |
| (16) White Balance Control: | ATW/ATWex/AWC/MANUAL, Selectable |
| (17) Color rolling reduction function: | Built-in, On or OFF, Selectable (CRR function) |
| (18) Private Mask Setting: | Built-in. Up to 8 areas |
| (19) Digital Noise Reduction: | Built-in, On or OFF, Selectable(DNR function) |
| (20) Optimum Monitor Output Selection: | Built-in, CRT or LCD types, Selectable |
| (21) Camera ID: | 1 Line, up to 24 characters(alphanumeric and symbols) |
| (22) Camera setup: | Possible |
| (23) Lens mount: | CS mount(C-mount adapter attachment possible) |
| (24) Lens flange back adjustment: | Built-in |
| (25) Image setting | 2 pattern setting possible |
| • Compression technology | H.264 or MJPEG |
| • Image size | NTSC 720x480,720x240,352x480,352x240 |
| • Frame rate | NTSC max. 30 fps, PAL max. 25 fps |
| • Bit rate (H. 264) | 64Kbps-8Mbps |
| • Image setting (MJPEG) | 5 stages |
| • Transfer mode | VBR/CBR |
| (26) Audio function | None |

(27) Network:	Ethernet 10Base-T/100Base-TX
(28) Protocol:	TCP, UDP, RTP/RTCP, RTSP, HTTP, FTP, NTP, ONVIF support Multicast delivery possible
(29) Monitoring:	Dedicated viewer or Dedicated recorder
(30) Power Requirement:	DC 12 V (+10.5V ~ + 15V) PoE (IEEE 802.3af) CLASS 0
(31) Power Consumption:	Approx. 4.5W
(32) Operating Temperature and Relative humidity:	-10 to +50°C, RH 30% to 90% (No Condensation)
(33) Outer dimensions:	60(W)×58(H)×70(D) mm(no protrusion included)
(34) Weight:	Approx. 310g
(35) Input/output connectors:	<ul style="list-style-type: none"> • LAN: RJ-45(Auto-MDI/MDIX) • DC 12V input: 2-pin terminal block • MONITOR OUT: BNC(Angle adjustment) • LENS: 4P(E4-191J-100 or equivalent)
(36) Supplied accessories:	<p>Instruction Manual</p> <p>Allen wrench (for flange back adjustment)</p> <p>Power input connector</p>

* Specifications and design are subject to change for product improvements without notice.

8. External Appearance

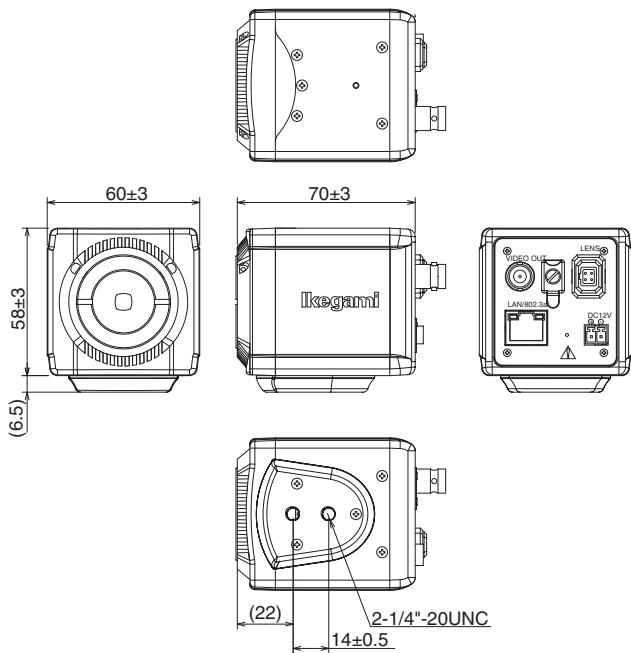

9. Setup Flow Chart

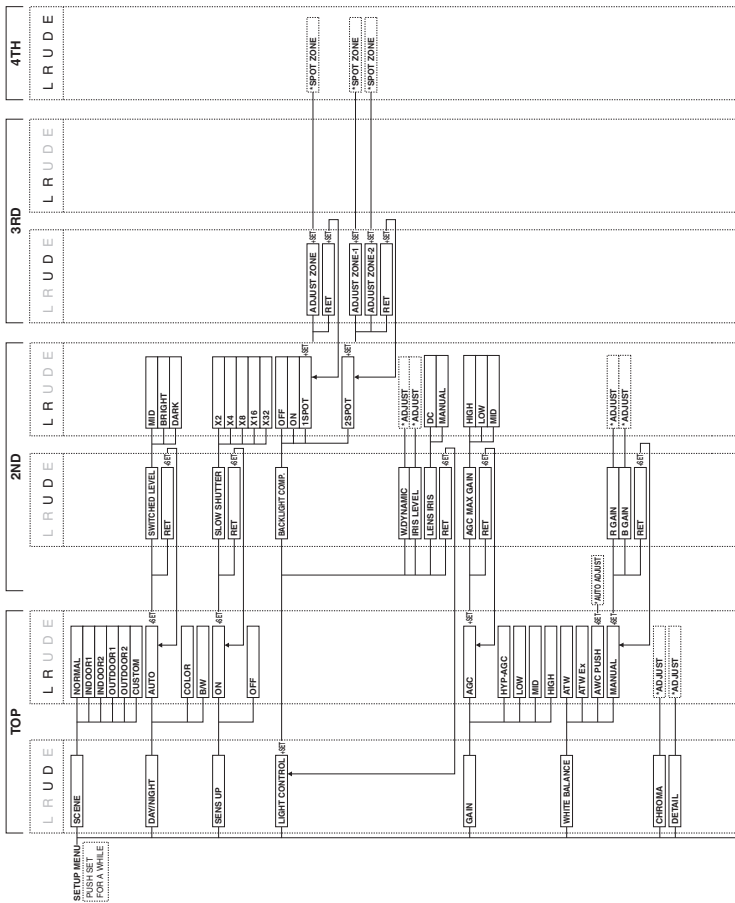



MEMO

A series of horizontal dashed lines for writing.

Ikegami

■ **Ikegami Electronics (U.S.A.), Inc.**

37 Brook Avenue, Maywood, N.J. 07607, U.S.A.
Phone: (201) 368-9171, FAX (201) 569-1626
www.ikegami.com

or

■ **Ikegami Electronics (Europe) GmbH**

Ikegami Strasse 1, D-41460 Neuss, Germany
Phone : 02131-123-0, FAX 02131-102820
www.ikegami.de

■ **Ikegami Electronics U.K. Office:**

Unit E1, Cologne Court, Brooklands Close,
Windmill Road, Sunbury-on-Thames,
Middlesex, TW16 7EB, U.K.
Phone:01932-769700 FAX 01-92-769710
www.ikegami.co.uk



Ikegami Tsushinki Co., Ltd.
NNA004272-01