

Specifications

Recording Media	
Internal	HDD (Data capacity 1 TB)
External	USB drive (Flash Memory or HDD)*1
Input Signal	
Digital (High Resolution Video)	
SDI	1080p, 1080i, 720p, 480i, 576i
DVI-D	640 x 480 - 1920 x 1200 (1920 x 1200 will be reduced to 1728 x 1080)
Analog (NTSC/PAL)	
Composite	1.0 Vp-p 75 ohm
S-Video	1.0 Vp-p 75 ohm luminance signal NTSC 0.286 Vp-p 75 ohm chrominance signal PAL 0.3 Vp-p 75 ohm chrominance signal
Digital	
Embedded (SDI input)	
Analog	
Audio	-9.4 dBv 10 kohm or more, unbalance φ3.5 stereo mini-jack
MIC	φ3.5 stereo mini-jack
Output Signal	
Digital (High Resolution Video)	
SDI	1080p, 1080i, 720p, 480i, 576i
DVI-D	640 x 480 - 1920 x 1200
Analog (NTSC/PAL)	
Composite	1.0 Vp-p 75 ohm
S-Video	1.0 Vp-p 75 ohm luminance signal NTSC 0.286 Vp-p 75 ohm chrominance signal PAL 0.3 Vp-p 75 ohm chrominance signal
Digital	
Embedded (SDI input)	
Analog	
Audio	-6 dBv 1 kohm unbalance φ3.5 stereo mini-jack

*1 Operation of attached third-party USB HDDs and USB drives is not guaranteed.
*2 Input/output of analog audio is not available when audio is embedded in the SDI signal.

Interface	
LAN	RJ45 (10Base-T/100Base-TX/1000Base-T)*3
USB-A	For recording x 2 (Front USB2.0) For inputting patient information x 1 (Rear USB2.0)
USB-B	For PC connection x 1 (Rear USB2.0)
REMOTE	φ2.5 mini-jack
External Switch	φ3.5 mini-jack for video x 1, photo x 1
External Recording Media	
USB Drive	Flash Memory or HDD
Format	FAT32
Video Data Process	
Still Image	JPEG
Video Compression	H.264
File Format	mov
Recording Time	180 hours (EQ: Economy Quality)
Audio Data Process	
Compression	LPCM
Sampling Freq	48 KHz
Quantifying Bit Number	16 bit

Safety Regulation/EMC

Safety Regulation	CB (IEC60601-1), CE (EN60601-1), NRTL/C (UL/CSA60601-1)
EMC	IEC60601-1-2, CSA60601-1-2, EN60601-1-2, FCC class B
Certified	FDA/Medical Class1

General

Display	3.5-inch, Full Color LCD	
Power	AC 100V - 240V ±10% 50/60 Hz 0.62A - 0.35A	
Operating Environment	Temperature	5 °C - 40 °C (+41 °F to +104 °F)
	Humidity	5 % - 80 % RH (non-condensing)
Dimension	W210.5 x H88.5 x D235 mm (W8.3 x H3.5 x D9.6 inches) (incl.rubber foot)	
Weight	Approx. 2.6 kg (5.7 lbs)	
Standard Accessory	Power cord x 1, Instruction Manual x 1	

*3 Data transmission speeds are limited to maximum of 100 Mbps in order to prioritize recording reliability.

Rear Panel



Dimensions (Unit:mm)

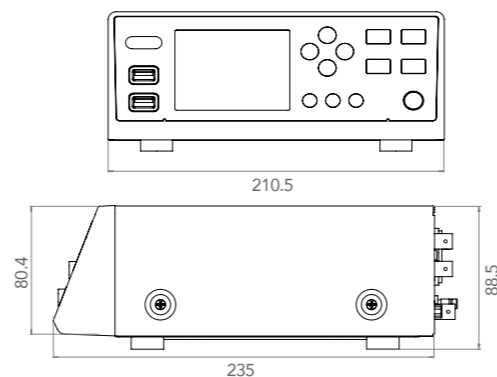

Optional Unit



[Precautions]

- Safety Precautions
Please read the instruction manual carefully before use to ensure safe operation.
- Copyright Notice
When recording video or audio, copying data to external media, or distributing content over a network using this product, please ensure full compliance with copyright laws and obtain permission from the copyright holder. We assume no responsibility for any copyright infringement by the user.
- Disclaimer on Recorded Content
We do not guarantee the integrity of recorded content. In the event that recording is not possible due to a product or external storage device malfunction, or if recorded content is lost or damaged for any reason, we will not provide compensation for restoration or repair, regardless of the warranty status.
- Product Specifications
To improve product quality, firmware updates may be made without prior notice.

Design and specifications are subject to change without notice.

Ikegami Tsushinki Co., Ltd.

URL: www.ikegami.co.jp/en/

Headquarters : 5-6-16 Ikegami, Ohta-ku, Tokyo 146-8567, Japan TEL.+81-(0)3-5700-1111
Beijing Office : Tower A Room No.823-824 Jia Tai International Mansion No.41
East Fourth Ring Road,Chaoyang District,Beijing ,China TEL.+86-10-8571-0350

Ikegami Electronics (U.S.A.), INC.

URL: www.ikegami.com

Headquarters : 300 State Route 17S, Mahwah, NJ 07430 USA TEL.+1-201-368-9171

Ikegami Electronics (Europe) GmbH

URL: www.ikegami.de

Headquarters : Ikegami Strasse 1, D-41460 Neuss, Germany TEL.+49-(0)2131-1230

Ikegami Electronics Asia Pacific Pte.Ltd.

URL: sg.ikegami.co.jp

Headquarters : 1 Tampines Central 5, #06-04 CPF Tampines Building, Singapore 529508 TEL.+65-6260-8820

U562A253-IB



Ikegami

Medical Grade Digital Video Recorder MDR-600HD-A

◆ High Quality - Full HD

◆ User Friendly - Simple Operation

◆ High Reliability - Triple Recording

◆ Network Transfer

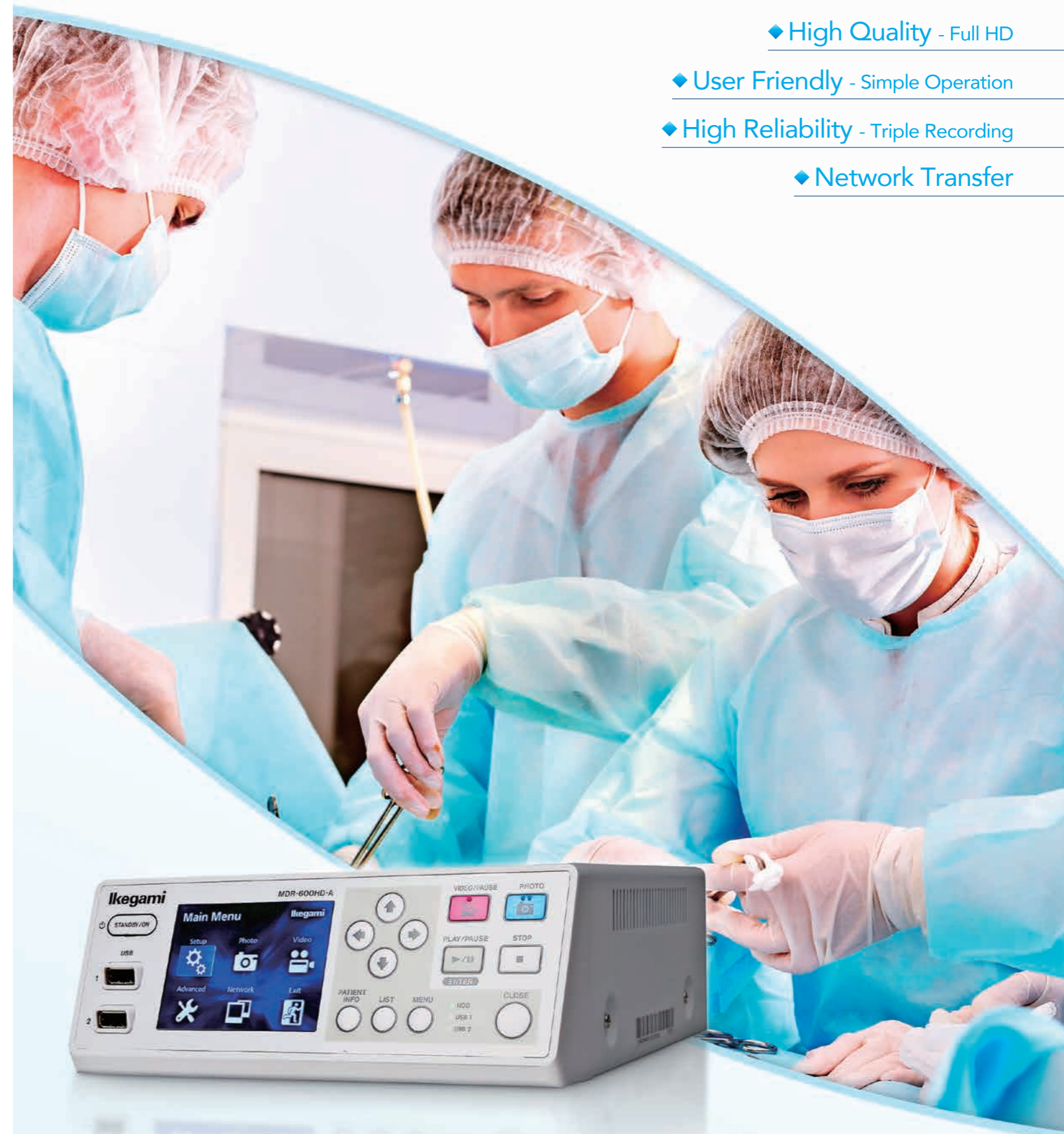

Trusted Performance and Ease of Use Capturing High-Quality Videos & Images for Healthcare

The MDR-600HD-A captures signals at various resolutions (640 x 480 to 1920 x 1080) from medical cameras with effortless operation and records to internal HDD and external USB storage media. Designed for reliability, it supports simultaneous video and still image recording and playback.



High Quality
Full HD

User Friendly
Simple Operation

High Reliability
Triple Recording

Network Transfer

Key Features

High Quality Video and Still Image

High quality SD/HD video and still image (640 x 480 to 1920 x 1080) can be recorded and played back.

Triple Recording

Experience effortless operation and unmatched data reliability. With the ability to record to three channels (internal HDD and two USB media), the MDR-600HD-A provides maximum flexibility and peace of mind for your important data management.

* Internal HDD can backup data.

Auto-Signal Detection & Auto-Resolution Following

The system automatically detects the signal type and resolution of a connected input device, allowing instant recording.

Network Function

Automatic and simultaneous recording to an FTP server/CIFS server via LAN. Copies of recorded images can also be transferred.*2

*2 Transfers are performed by folder.

Various Search Function

Easily search videos and still images by patient ID, name, or recording date for quick and efficient playback.

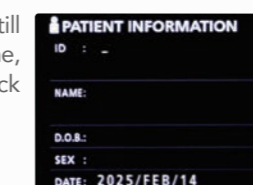

Simultaneous Recording and Playback

Still image can be saved and/or replayed during video recording.

Simple Operation

Just one button can start recording video, also just button can start recording still image.

Built-in LCD Monitor

The built-in LCD monitor allows you to preview inputs and playback images precisely. Stay informed of real-time status updates and remaining capacity, ensuring flawless and efficient operation.



Easy Recording with External Controller

Connecting external controllers such as a foot switch to the MDR-600HD-A allows convenient video recording, pausing and still image capture, providing greater control and flexibility during operation.

Compact Design

A compact body packed with powerful features for maximum performance and efficiency.

System Configuration (example)

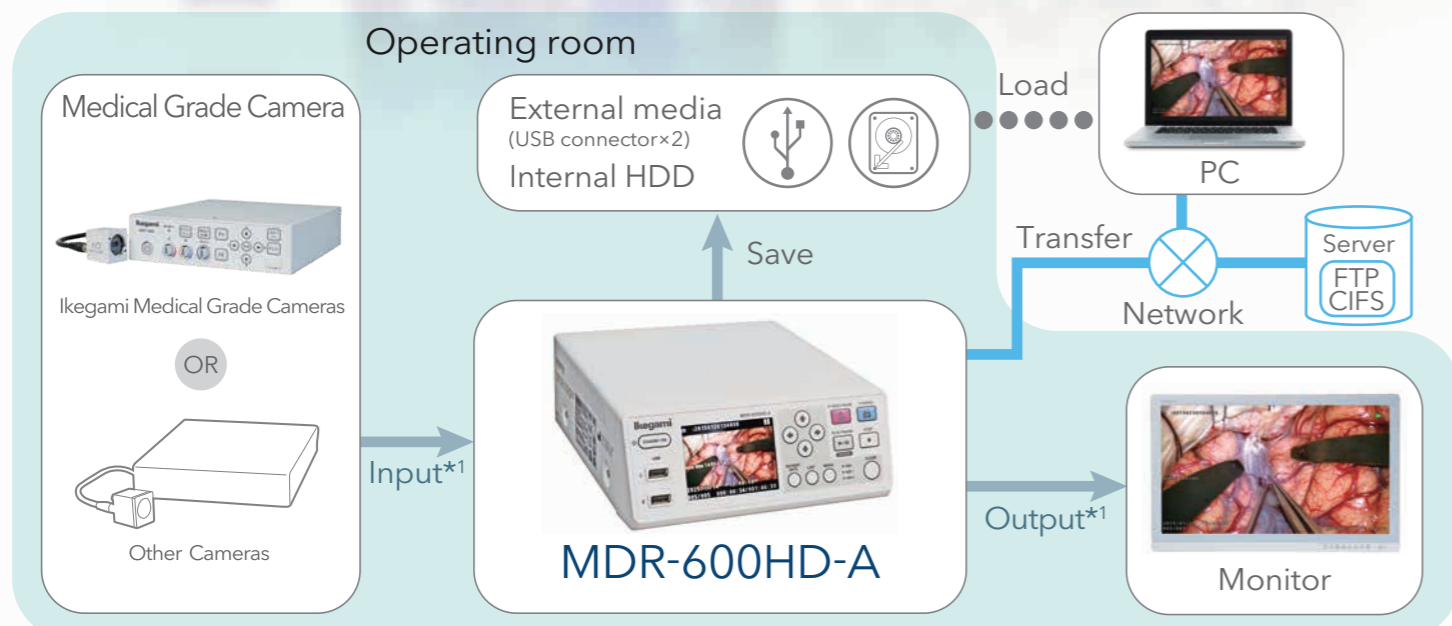

*1 Digital: SD-SDI/HD-HDI/DVI-D | Analog: Composite/S-Video
Input signal and output signal format must be the same.

Recording Time

HD (1920 x 1080)

Media	LQ (12 Mbps) without audio signal	EQ (12 Mbps)	SQ (18 Mbps)	HQ (24 Mbps)
HDD (1 TB)*5	200 hours	180 hours	120 hours	90 hours
External Media (1 TB)	200 hours	180 hours	120 hours	90 hours

SD (640 x 480)

Media	LQ (2 Mbps) without audio signal	EQ (5 Mbps)	SQ (8 Mbps)	HQ (10 Mbps)
HDD (1 TB)*5	1100 hours	360 hours	270 hours	200 hours
External Media (1 TB)	1100 hours	360 hours	270 hours	200 hours

*3 Recording time in EQ, SQ, HQ mode is the time for simultaneous recording of video and audio.

*4 Recording time in LQ mode is the time for video recording only.

*5 If free space is less than 100 GB, data will be deleted from the oldest files.