

HC-HD300 (FA-300)

**HIGH DEFINITION CAMERA SYSTEM
OPERATION MANUAL**

Ikegami

HC-HD300 (FA-300)

HIGH DEFINITION CAMERA SYSTEM OPERATION MANUAL

OUTLINE

1

NAME and FUNCTION

2

INSTALLATION and
CONNECTION

3

OPERATION

4

CAMERA SETTINGS and
ADJUSTMENT

5

TROUBLE SHOOTING and
MAINTENANCE

6

SPECIFICATIONS

7

CHANGING INFORMATION

English

Instructions for Disposal of Electric and Electronic Equipment in Private Household



Disposal of used Electric and Electronic Equipment
(Applicable in the European Union and other European countries with separate collection systems)

This symbol on the product, or in the related documents in the package, indicates that this product shall not be treated as normal household waste. Instead, it should be taken to a proper applicable collection point or depot for the recycling of electric and electronic equipment.

By ensuring this product is disposed of correctly, you will help prevent possible negative consequences for the environment and human health, which could otherwise be caused by inappropriate waste handling of this product. The recycling of materials will help to conserve natural resources.

For more detailed information about recycling of this product, please contact your local city authority, your household waste disposal service or the place where you purchased the product.

Deutsch

Vorschriften für die Entsorgung von elektrischen und elektronischen Geräten in Privathaushalten



Entsorgung von gebrauchten elektrischen und elektronischen Geräten
(In der Europäischen Union und anderen europäischen Ländern mit separaten Sammelsystemen anwendbar.)

Das auf dem Produkt angebrachte Symbol, bzw. die Symbole in den in der Packung beiliegenden Dokumenten, weisen darauf hin, dass dieses Produkt nicht als normaler Haushaltsmüll behandelt werden darf. Es muss deshalb an einer dafür vorgesehenen Sammelstelle abgeliefert werden, in der das Recycling von elektrischen und elektronischen Geräten durchgeführt wird.

Durch die ordnungsgemäße Entsorgung dieses Produkts tragen Sie dazu bei, dass unsere Umwelt und unsere Gesundheit nicht durch unsachgemäße Entsorgung negativ beeinflusst wird. Mit dem Recycling von Materialien tragen wir zur Bewahrung der natürlichen Ressourcen bei.

Für nähere Informationen hinsichtlich des Recyclings für dieses Produkt sprechen Sie bitte mit Ihrer zuständigen Behörde, Ihrer Hausmüll-Entsorgungsstelle oder dem Geschäft, wo Sie das Produkt gekauft haben.

Français

Consignes de mise au rebut des appareils électriques et électroniques dans les foyers privés



Mise au rebut des appareils électriques et électroniques
(Applicable dans l'Union Européenne et autres pays d'Europe ayant un système de récupération séparé)

Ce symbole apposé sur le produit ou dans les documents liés se trouvant dans l'emballage indique que ce produit ne doit pas être traité comme un déchet ménager normal. Il doit être porté à un point de récupération correct ou à un dépôt pour le recyclage des appareils électriques et électroniques.

En vous assurant que ce produit est correctement mis au rebut, vous aiderez à empêcher les conséquences possibles pouvant affecter l'environnement et la santé humaine, pouvant être causées par une mauvaise manipulation des déchets de ce produit. Le recyclage des matériaux favorise la conservation des ressources naturelles.

Pour des informations plus détaillées concernant le recyclage de ce produit, veuillez contacter les autorités locales, votre service de mise au rebut des déchets ménagers ou le lieu d'achat de votre produit.

Español

Instrucciones para eliminar equipos eléctricos y electrónicos de una casa privada



Eliminación de equipos eléctricos y electrónicos usados
(Normas aplicables en la Unión Europea y en otros países europeos con diferentes sistemas de recogida)

Este símbolo en el producto, o en los documentos relacionados, indica que este producto no deberá ser tratado como un residuo doméstico normal. En cambio, deberá ser llevado a un punto o lugar donde los equipos eléctricos y electrónicos sean recogidos para ser reciclados.

Asegurándose de que este producto sea eliminado correctamente, usted ayudará a impedir las posibles consecuencias negativas sobre el medio ambiente y la salud humana que podrían ser causadas por el manejo inapropiado de este producto como residuo doméstico. El reciclado de los materiales ayudará a conservar los recursos naturales.

Para conocer una información más detallada acerca del reciclado de este producto, póngase en contacto con las autoridades de su localidad, con su servicio de recogida de residuos domésticos o con el comercio donde adquirió el producto.

PRODUCTS CONFORMING TO RoHS DIRECTIVE

Following products described in this manual are products conforming to RoHS directive.

· HC-HD300	Color Camera
· VFL200HD, VFL-P700	Viewfinder
· BSF-300	Base Station
· OCP-10	Operation Control Panel
· MCP-170	Maintenance Control Panel
· BSH-300	Base Station Hub
· PSU-300	Power supply unit

Products conforming to RoHS directive include products that do not contain specified hazardous substances such as lead, mercury, cadmium, hexavalent chromium, polybrominated biphenyl (PBB) and polybrominated diphenyl ether (PBDE) in electrical and electronic equipment excluding following exemption applications based on the EU directive (Directive2002/95/EC).

* About RoHS Directive

The RoHS directive stands for "the Restriction of the Use of Certain Hazardous Substances in Electrical and Electronic Equipment" and is one of environmental directives in Europe. This directive restricts the use of specified hazardous substances in electrical and electronic equipment.

● Applications exempted from RoHS directive compliance

Followings applications are permitted as exemptions from RoHS directive compliance.

- Mercury in compact fluorescent lamps not exceeding 5mg per lamp
- Mercury in straight fluorescent lamps for general purposes not exceeding:
 - halophosphate 10mg
 - triphosphate with a normal lifetime 5mg
 - triphosphate with a long lifetime 8mg
- Mercury in straight fluorescent lamps for special purposes
- Mercury in other lamps not specifically mentioned in this Annex
- Lead in the glass of cathode ray tubes, electronic components and fluorescent tubes
- Lead as an alloying element in steel containing up to 0.35% lead by weight, aluminum containing up to 0.4% lead by weight and as a copper alloy containing up to 4% lead by weight
- Lead in following items
 - Lead in high melting temperature type solders (i.e. tin-lead solder alloys containing more than 85% lead)
 - Lead in solders for servers, storage and storage array systems
 - Lead in solders for network infrastructure equipment for switching, signaling, transmission as well as network management for telecommunication
 - Lead in electronic ceramic parts (e.g. piezoelectronic devices)
- Cadmium plating except for applications banned under Directive 91/338/EEC amending Directive 76/769/EEC relating to restrictions on the marketing and use of certain dangerous substances and preparations
- Hexavalent chromium as an anti-corrosion of the carbon steel cooling system in absorption refrigerators
- Lead used in compliant pin connector systems
- Lead as a coating material for the thermal conduction module C-ring
- Lead and cadmium in optical and filter glass
- Lead in solders consisting of more than two elements for the connection between the pins and the package of microprocessors with a lead content of more than 80% and less than 85% by weight
- Lead in solders to complete a viable electrical connection between semiconductor die and carrier within integrated circuit Flip Chip packages
- Decabrominated diphenyl ether (Deca-BDE) in polymeric applications

MAINTENANCE OF PRODUCTS CONFORMING TO RoHS DIRECTIVE

Work with care about followings for maintenance of products conforming to RoHS directive.

1. Identification

- For products conforming to RoHS directive, the letter "E" is appended at the end of the serial number on the label. For models that the letter cannot be appended to the serial number, the letter "E" will be described in a distinguishable position on the label. A description example on a main label is shown below.

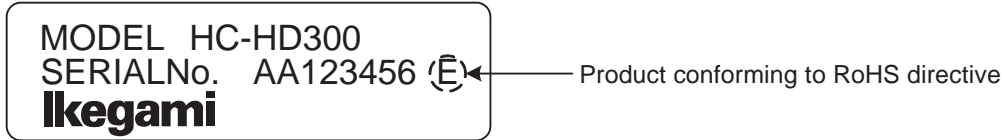

Label

- Print-circuit board of the products conforming to RoHS directive is manufactured by following methods.
 - [1] Blue resist ink is used for the print-circuit board. (The color of conventional print-circuit board is green.)
 - [2] Either one of the following marks is indicated by a serigraph or label.



Phase 3A



Phase 3

2. Soldering

Since the melting point of lead-free solder used for the products conforming to RoHS directive is 20 to 45 degrees Celsius higher than that of conventional solder with lead (Sn-Pb eutectic solder), a high temperature needs to be set to a soldering iron. Taking allowable temperature limit of the parts and stable work into consideration, use a soldering iron with excellent thermal recovery characteristics.

- Recommended solder composition is "Sn/3.0Ag/0.5Cu" or equivalent.
- Separate the soldering iron exclusively for RoHS products and the soldering iron for conventional use.
- Set the temperature of the soldering bit to 350 to 370 degrees Celsius.
 - The temperature may need to be adjusted according to the size of the copper foil land on the print-circuit board and the tip width of the soldering bit.
- Finish by a lead-free solder looks dull or whitish compared to conventional solder with lead.
- If the customer mixed the lead-solder with the main body wiring or the circuit board, it becomes guarantee off the subject. Ikegami doesn't guarantee to do the repair work. Because the solder polluted with lead cannot be removed.

3. Parts

Be sure to use parts conforming to RoHS directive.

INFORMATION TO THE USER



1. This equipment has been tested and found to comply with the limits for a Class A digital device, pursuant to Part 15 of the FCC Rules. These limits are designed to provide reasonable protection against harmful interference when the equipment is operated in a commercial environment. This equipment generates, uses, and can radiate radio frequency energy and, if not installed and used in accordance with the instruction manual, may cause harmful interference to radio communications. Operation of this equipment in a residential area is likely to cause harmful interference in which case the user will be required to correct the interference at his own expense.
Changes or modifications not expressly approved by the party responsible for compliance could void the user's authority to operate the equipment.
2. Declaration of conformity
The CE mark means that the following products will meet the Directive 2004/108/EC, 2006/95/EC and the Standards EN55103-1 E4-E5, EN55103-2 E4-E5 (for EMC), EN60950-1 (for LVD).
For European customer.
3. Rated current value of the camera when BSF-300 are used for the system operation is shown below.

		Rated current value
· BSF-300	DC50V	: 1.1A





SAFETY PRECAUTIONS

This manual describes the precautions using various pictorial symbols for you to use the product safely. Please read these precautions thoroughly before use. The symbols and meanings are as follows:

The following hazard alert symbols are used to indicate the level of impact on the body or property when you do not follow the precautions.

 WARNING	Indicates that mishandling of the product by ignoring this label may lead to a danger resulting in a serious injury or death.
 CAUTION	Indicates that mishandling of the product by ignoring this label may lead to a danger resulting in an injury or property damage.

The following symbols are used to indicate the expected injury or hazards when you do not follow the precautions.

	Indicates general cautions on such matters as safe work, procedure, and installation location. Mishandling may not directly lead to death, injury, or property damage.
	Indicates that mishandling may cause an electric shock.
	Indicates that mishandling may cause a fire.
	Indicates that mishandling may cause injury.

The following symbol is used to indicate other precautions to prevent damage or hazard from occurring:

	Indicates prohibited action.
---	------------------------------

■ Handling Precautions

WARNING

Regarding the Product



Do not disassemble or modify the product which is not described in this manual. Doing so may cause fire, electric shock, or injury.

Regarding the Power



When you disconnect the cable, be sure to hold the plug and pull. Failure to do so may cause a fire or electric shock due to a damaged cable.



To inspect or operate on the inside of the equipment, turn off the power and wait for one or two minutes before starting work. High voltage is present in some modules and connectors of this product.

When you want to intercept a power supply surely, I pull a fiber cable of the camera side, or, please pull an AC plug of the BS/CCU side.

CAUTION

Regarding the Product



Do not lift or hold the camera by the projection parts.

If you lift or hold the camera by the viewfinder or the lens, you are prone to dropping it. Moreover, the connection parts between the camera and the viewfinder, or the camera and the lens may be exposed to unnecessary pressure, which may cause equipment damage.

Always install the accessories or connect the cables after placing the camera on a fixed position.

When installing such accessories as lens or microphone, fix the camera on a stable place (e.g. on a table, a tripod, etc.).



Avoid use or storage in the following conditions:

- Extremely high/low temperature
- In direct sunlight for a long time, or near a heater
- High humidity or dusty
- Exposed to water or other liquid
- Strong vibration or shock
- Strong magnetic field or radio waves
- lightning
- In rain without the rain cover

Regarding the Product

Be sure to hold the plug and pull when you disconnect the cable.
Failure to do so may cause a fire or electric shock due to a broken cable.

Avoid moving the equipment suddenly from an extremely cold place to a warm place.
Condensation may occur in the CMOS image sensor or other parts.

Do not drop or insert a metal object such as a pin or a foreign object into the equipment.

Do not spread or spill water or other liquid on the equipment.

Do not subject the equipment to a strong shock or vibration.
Doing so may cause damage or malfunction of the equipment.

Since semiconductor pixels are adapted in CMOS image sensor, image burn-in will not occur in normal operation. When you shoot subjects with an excessive amount of light (e.g. sun, laser beam, etc.) for a long time, pay attention to temperature rise inside the CMOS sensor.

Before connecting a VTR or accessories, make sure that the camera and equipment to be connected are powered off. Also, be sure to use dedicated cables.

Laser beams may damage the CMOS image sensors. If you shoot a scene that includes a laser beam, be careful not to let a laser beam become directed into the lens of the camera.

Excessive sound pressure from the headset may cause a hearing loss.

Regarding the Power and the Lithium Battery

Use the product in compliance with the rating of the fuse within the product and that within the Camera Control Unit (BS). Otherwise, a fault can occur.



Do not use an unspecified battery.
Wrong usage of batteries may cause liquid leak, explosion, and heat, and at worst injury or fire.
When changing or discarding a battery, please contact Ikegami's sales and service centers.
Risk of explosion if battery is replaced by an incorrect type. Dispose of used batteries according to the instructions.

Regarding the Fiber Connector and the Fiber Optic Cable

Fiber optic cable connectors are quite similar to each other in shape. Before connecting fiber optic cables, thoroughly check male or female, the diameter, type and manufacturer of connectors.

If the ferrule is dirty, wipe the dirt off with cotton swabs soaked in alcohol.

The fiber optic cable supplies DC50V power from the BS to the camera.
Although safety measures are fully taken such as the safety circuit that stops the power supply from the BS within a short time after an optical fiber cable is removed or short-circuited, never force to bend, twist, or damage the cable, and take great care when handling.

Regarding the Fiber Connector and the Fiber Optic Cable



Take care for the following:

- When disconnecting the fiber optic cable from the camera or from the BS, always hold the fiber connector (plug) and not the cable.
- Do not crush the cable.
- Since there can be various obstacles (such as a corner of a building, glass, rough ground surface) in places where the cable is connected, do not drag the cable without winding.
- Turn off the power before removing the fiber optic cable.
- The allowable radius of curvature of fiber optic cables is approximately six times of the outer diameter of cables (approx. 60 mm for a $\phi 9.2$ mm-wide cable). Do not force to wind less than specified. Forcible winding can break fiber leads within the cable.

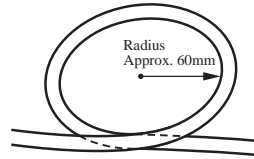

Fiber Optic Cable

- When connecting a fiber optic cable to a fiber connector, anchor the fiber optic cable with a cable clamp.

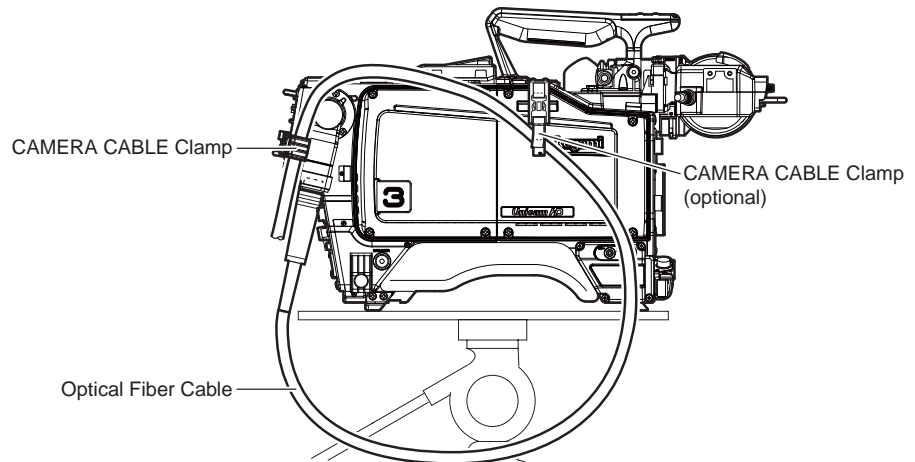

■ Environmental Cautions

Regarding the product



When continuously operating the product in a rainy, cold or hot conditions, use a rain cover, cold-weather cover, and shade cover respectively.

.....

Avoid storing the product in a dusty place for a long time. If unavoidable, use a dustproof cover.

.....

When shooting in places such as airports, military bases or transmitting stations where magnetic and radio fields are excessively strong, completely shield the camera by covering it with aluminum foil.

■ Maintenance

Regarding the product



Before performing maintenance on the product, be sure to turn off the power for safety and for protection against malfunction.

.....

Clean the product using a dry and soft cloth.

.....

If the stain is hard, soak the cloth with water or detergent, wring well and wipe. If you use detergent, wipe off the detergent with a cloth that is soaked in just water and wrung well.

■ Notice for Use

- When carrying or storing the product, always use a carrying case.
- Before shooting important subjects, take test shots to obtain the desired effect.
- After using the product, always turn off the power.

■ Regular Maintenance Recommended

This product includes parts that wear out and have a limited life even in proper use or storage. Therefore, regular maintenance is recommended to extend the life and safe use of this product for a long time. Please contact Ikegami's sales and service centers for the regular maintenance and repair of our products.

HOW TO READ THE OPERATION MANUAL

This page explains general notes on reading the HC-HD300 Operation Manual, and the symbols and notations used in the manual.

■ Notes on the Manual

- This manual is written for readers with a basic knowledge of handling broadcast cameras.
- The contents of this manual are subject to change without notice in the future.

■ Symbols

The symbols used in this manual are as follows:

CAUTION:	Things you have to be careful during operation. Be sure to read.
Note:	Supplementary information or guidance
Reference:	Sections where related information is available
Term:	Explains the meaning of a term you need to know.

■ Notations

The following notations are used in this manual.

This product, camera	Indicates HC-HD300. (Including FA-300)
BS	Indicate BSF-300 Base Station.
OCP	Basically indicates OCP-10 Operation Control Panel.
MCP	Basically indicates MCP-170 Maintenance Control Panel.
" " _ " " _ " "	Indicates the items enclosed by double quotes (") are to be selected and confirmed in the order shown.

■ Illustrations and Displays

The illustrations and displays in the text are provided for explanation and may be slightly different from the actual equipment or image.

■ Related Manuals

- BSF-300 Base Station Operation Manual
- OCP-10 Operation Control Panel Operation Manual
- MCP-170 Maintenance Control Panel Operation Manual
- BSH-300 Base Station Hub Setup Manual

■ **Structure of Operation Manual**

HC-HD300 High Definition Camera System Operation Manual is intended to both safely and smoothly operate the HC-HD300. The Operation Manual consists of seven chapters. By reading it in sequence, you can smoothly perform a series of steps, from connection to operation. Furthermore, by combination use of BSF-300 (base station), this product enables not only stand-alone VTR location shooting but also various shooting styles such as studio shooting and field shooting as a system camera. Refer to other manuals such as for the BSF-300.

Chapter 1	<p>OUTLINE</p> <p>Explains the features and the main operating systems of this product. If you are not familiar with HC-HD300 High Definition Camera System, please start with this chapter.</p>
Chapter 2	<p>NAME and FUNCTION</p> <p>Explains the name and function of each part of the Camera.</p>
Chapter 3	<p>INSTALLATION and CONNECTION</p> <p>Explains how to mount this product, lens, and viewfinder. Taking examples of studio shooting, stand-alone shooting, and VTR location shooting, explains how to connect this product to the peripheral equipment.</p>
Chapter 4	<p>OPERATION</p> <p>Explains setup before shooting. Before shooting for the first time, read this chapter and check that this product is operating normally.</p>
Chapter 5	<p>CAMERA SETTINGS and ADJUSTMENT</p> <p>This product realizes detailed settings to support a wide range of operations and various video expressions through the menu window. This chapter explains switch settings, menu settings, and DIP switch settings on the modules inside of the Camera.</p>
Chapter 6	<p>TROUBLE SHOOTING and MAINTENANCE</p> <p>When the alarm lamp lights during the operation of this product, read here to know the problem. This chapter also explains the regular maintenance such as cleaning of connectors and resetting of breaker.</p>
Chapter 7	<p>SPECIFICATIONS</p> <p>Explains the specifications of this product.</p>
	<p>CHANGING INFORMATION</p> <p>Contains revision information of design revision or customer-specific specification requested by customers. Read by comparing with the main text of the operation manual. ("CHANGING INFORMATION" may be sent to you later on.)</p>

HC-HD300 (FA-300)

High Definition Camera System Operation Manual

PRODUCTS CONFORMING TO RoHS DIRECTIVE . . .	i
MAINTENANCE OF PRODUCTS CONFORMING TO RoHS DIRECTIVE	ii
INFORMATION TO THE USER	iii
SAFETY PRECAUTIONS	iv
HOW TO READ THE OPERATION MANUAL	ix

Chapter 1. OUTLINE

1.1 Features of This Product	3
Fusion of High Quality CMOS and Superb Image Processing Techniques	3
Support for Picture Optimization	3
Pursuit for Superb Operation and Ease of Use . .	4
Equipped with Various Interfaces	4
Support Function for Data Setup	4
1.2 Operating Systems	5
1.3 Connection Diagram	9

Chapter 2. NAME and FUNCTION

2.1 Camera and Viewfinder	13
Camera Right View	13
Camera Left View	17
Camera Front View	19
Camera Rear View	21
Viewfinder (VFL200HD)	25
2.2 Displays in the Viewfinder	27
LED Indicator	27
Center Marker, Safety Marker, Frame Marker	27
Zebra Indicator	27
Side Mask Function	28
Display Mode	28
Viewfinder Display	28

Chapter 3. INSTALLATION and CONNECTION

3.1 Preparation	33
Product Use Environment	33
Make sure the Power Switch is OFF	33
Connection Examples for Typical Operating Systems	33
3.2 Camera and Peripheral Installation and Connection	41

Mounting/Removing the Camera on/from the Tripod	41
Mounting and Removing the Lens	43
Mounting and Removing the Viewfinder . . .	45
Attaching the Microphone	47
Connecting the Headset	48
Attaching the Shoulder Belt	48
3.3 Power Connection	49
Power Supply from AC Adapter	49
Power Supply from BS	50
3.4 Monitor Connection	52
Connecting Camera and Monitor	52
3.5 BS Connection	53
Connecting Camera and BS	53

Chapter 4. OPERATION

4.1 Operating Procedures	57
4.2 Switch Position Check	58
4.3 Turning ON Power	60
Power Supply from AC Adapter	60
Power Supply from BS	60
4.4 Viewfinder Adjustment	62
Diopter Adjustment and Screen Adjustment . .	62
Display Mode Check	62
4.5 Output Signal Check	63
Color-Bar Signal Check	63
Test Pulse (CAL Signal) Check	64
External Chart Check	64
4.6 Auto Setup	65
Auto White Balance	66
Auto Black Balance	67
4.7 Preparation for Shooting in Particular Environment	68

Chapter 5. CAMERA SETTINGS and ADJUSTMENT

5.1 Settings Using Switches on the Camera . . .	71
Adjusting Headset Volume	71
Selecting Shutter Speed	72
Enhancing the Vertical Resolution (Super-V Function)	74
Switching the GAIN	75
Allocating Functions to the P.FUNC Switch . .	76
Screen Detail Enhancement (DTL)	77
5.2 Settings from the Menu	78

Basic Operation of the Menu 78
Menu Configuration and content 81
5.3 Using the Memory Card 100

**Chapter 6.
TROUBLE SHOOTING and
MAINTENANCE**

6.1 Alarm Lamp on the OCP or MCP Flashes
ON and OFF 107
6.2 "TEMP!!" or "FAN!!" Appears on the
VF Screen 108
6.3 Initializing the Settings of this Product 109
6.4 Cleaning Camera Connectors 111
6.5 Reset the Breaker 114
6.6 Sensor defect correction 115

Chapter 7. SPECIFICATIONS

7.1 HC-HD300 Specifications 119
7.2 External Dimensions Diagram 121
7.3 External Connections 125
7.4 Scene File 135

CHANGING INFORMATIO 137

OUTLINE



■ HC-HD300

The Hc-HD300 realizes high quality pictures and advanced functions using intelligent digital techniques nurtured in the HDK series. Furthermore, we succeeded to create a small, light-weighted camera system whose weight and balance has been sought after for the improvement of the portable camera operation.

- A 16-bit processor produces pictures with a board range of gradation from dark parts to highlight parts.

1.1 Features of This Product

Fusion of High Quality CMOS and Superb Image Processing Techniques

■ 2.5 Million pixel 3CMOS

A 2.5-million pixel 1/3-inch CMOS sensors are employed to achieve superb picture quality with a horizontal resolution of 1,000 TV lines and an S/N ratio of more than 58dB.

■ Newly developed digital process IC

New digital processing within the camera digitizes not only video signals but also nonlinear image processing used for the white shading correction and Gamma correction. This achieves high quality pictures, advanced functions, and high reliability with stability.

Support for Picture Optimization

■ DTL Correction

Includes a horizontal and vertical DTL correction circuit in which red, green and blue video are independently digitally processed.

You can obtain the full resolution HDTV picture quality with little noise even in the stand-alone VTR shooting.

■ Wideband Digital DTL

Includes an advanced digital DTL circuit to improve reproduction, including texture and sheen. Furthermore, improves richer reproduction of details with little noise in dark background and details in skin tone.

■ Quick EZ Focus Assist Function

A focus assist area is provided in the VF image to aid the camera operator in finding the focus. The focus assist area can be set to display only when focusing, triggered by manual or motor drive movement of the lens focus.

■ Six-axis + Two-axis Color Corrector

Includes a color corrector function that enables you to adjust hue and saturation of three primary and three secondary colors (R, G, B, cyan, yellow, magenta). Also, includes a color corrector function to adjust two selected colors.

■ Super KNEE

Includes a super KNEE function which produces the KNEE process with less saturation loss, and without changing the hue of the highlights. Produces a more natural highlight appearance, rather than washing out the color.

■ Lens aberration correction function

It obtains correction data from corresponding lenses and automatically corrects the chromatic aberration on the basis of the position information of zoom and focus of the lens.

■ Advanced matrix function

It is possible to perform appropriate color conversion under special circumstances; for example, under monochromatic blue light source such as stages of concert and play, for which the color conversion range was exceeded with a conventional matrix function.

Pursuit for Superb Operation and Ease of Use

■ High Performance Color Viewfinders

A 2" 16:9 LCD HDTV color viewfinder is adopted for portable operation. Full color video monitoring is possible with QHD (960×540) high resolution. 7" LCD studio color viewfinders can be also selected as an option.

■ Low Center-of-Gravity, Light Weight, and Excellent Balance

Designed with a low center-of-gravity, light weight, and excellent balance, in consideration of the balance when shooting on the shoulder and holding at various angles.

■ On-Line Diagnostics

An on-line diagnostic system enables monitoring the status of circuits including video, control, fiber optic transmission, pulses and power supply. This enables you to always grasp the status information of the camera.

■ Rotating Camera Cable Connection

Employs a rotating fiber camera cable connector. This enables studio shooting and field shooting at various angles.

■ Return Switch

A switch to choose RET-1 or RET-2 is also equipped on the handle grip of the camera to easily switch when low angle shooting.

■ Dockable chassis structure

It has a basic structure that can be separated into camera and transmission parts and provides high extensibility and maintainability.

■ Adoption of NEUTRIK fiber connector

With adoption of NEUTRIK OpticalCON DUO connectors, the hybrid fiber/copper camera cable provides full signal interface with the base station with flexible cabling configuration.

Equipped with Various Interfaces

- The camera includes HD-SDI signal output.
- The camera has an interface for return video in HD-SDI signal form. (RET HD-SDI signal transmission)
- An 8-core composite fiber optic camera cable (two single-mold fibers, four power leads, two control signal leads) connects between the camera and the BSF-300, and the transmission complies with BTA S-004A (Japan standard) and SMPTE292M (International standard). Signal transmission and power supply are possible for a length up to 350 m. (If VFL-P900 is used for the viewfinder, the maximum length is 250 m.)
- DC12V (Maximum 0.5A) can be supplied for the camera.
- The transmission distance between the BS and the power supply unit, can be extended up to 10km by connecting a single mode fiber cable by installing a power supply unit (PSU-300) between the camera and BSF-300.
- When the camera is connected to the BSF-300, you can use the data trunk channel (RS-422) for virtual studio applications.

Support Function for Data Setup

The level adjustment and settings of each menu for the camera can be easily set up by calling up the ENGINEER SET FILE that is set by user engineer or the FACTORY SET FILE that is set at shipment according to environment and shooting conditions where the camera system is used. This enables quick initialization of the camera status even though the settings are changed.

Reference:

Refer to "6. TROUBLE SHOOTING and MAINTENANCE [Initializing the Settings of this Product]" (P109) for the ENGINEER SET FILE and FACTORY SET FILE.

**Example of Minimum Configuration of System Camera
(Up to 32 cameras and 1 MCP)**

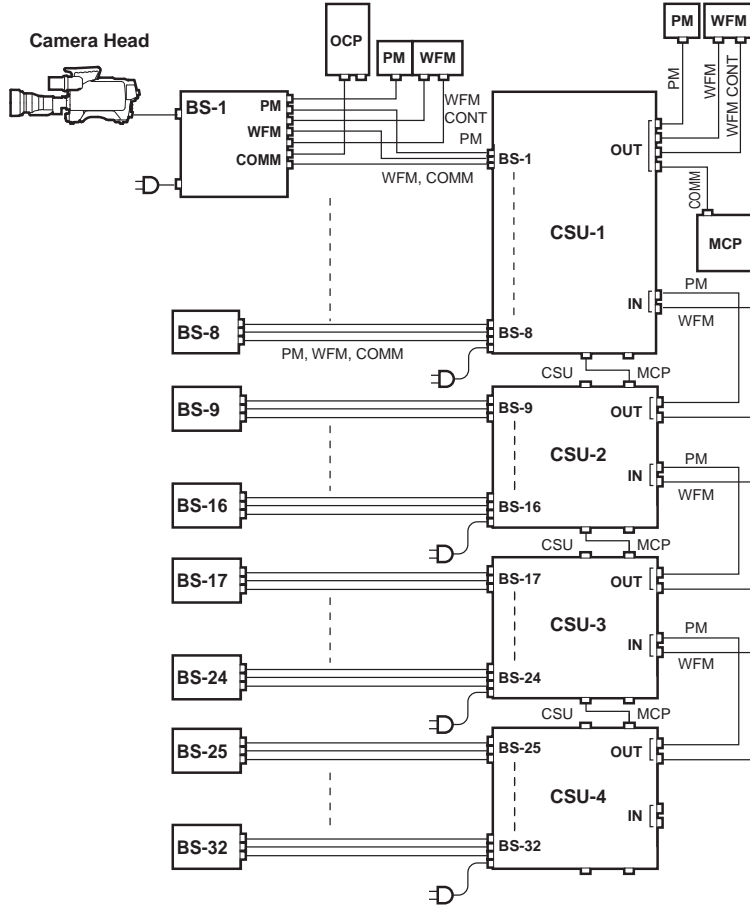

**Example of VTR Location Configuration
(Minimum Configuration of Camera, VTR, and PM)**

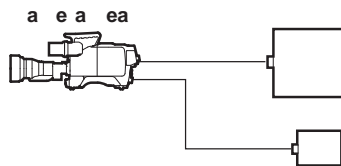

■ Network Connection (Basic bus connection)

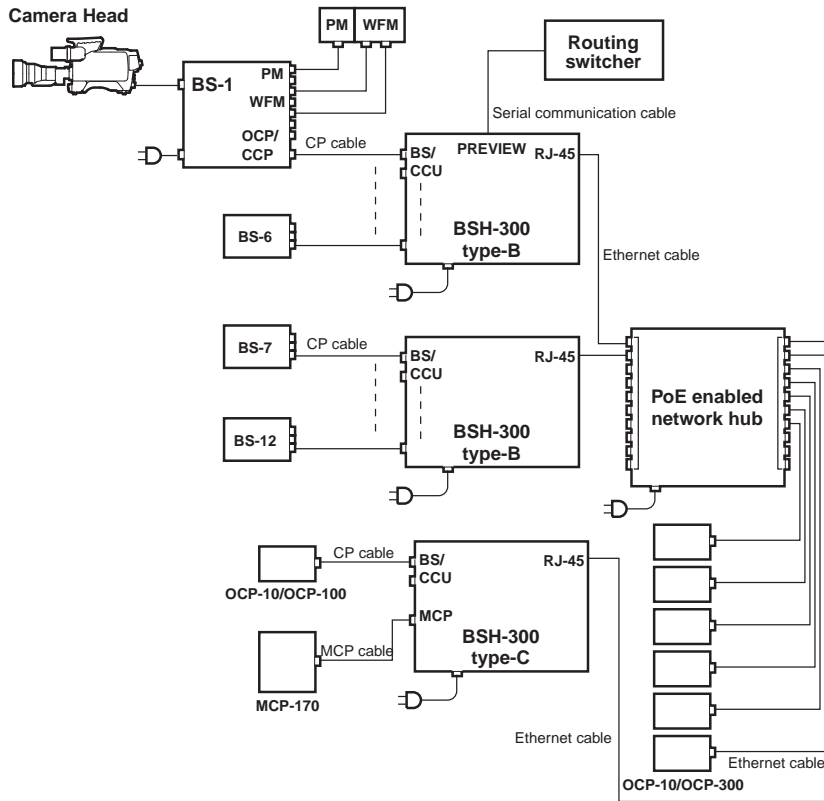

Term:

BSH (Base Station Hub)
It is designed as the HUB unit which employs command converter for Ikegami's non-network capable camera head/BS/CCU to use under network control system.

Note:

- The OCP/CCP connector and MCP/CCP connector on the CCU cannot be used with the network connector at the same time in this configuration.

Note:

- Ethernet compatibility is optional for the OCP-10.

1.3 Connection Diagram

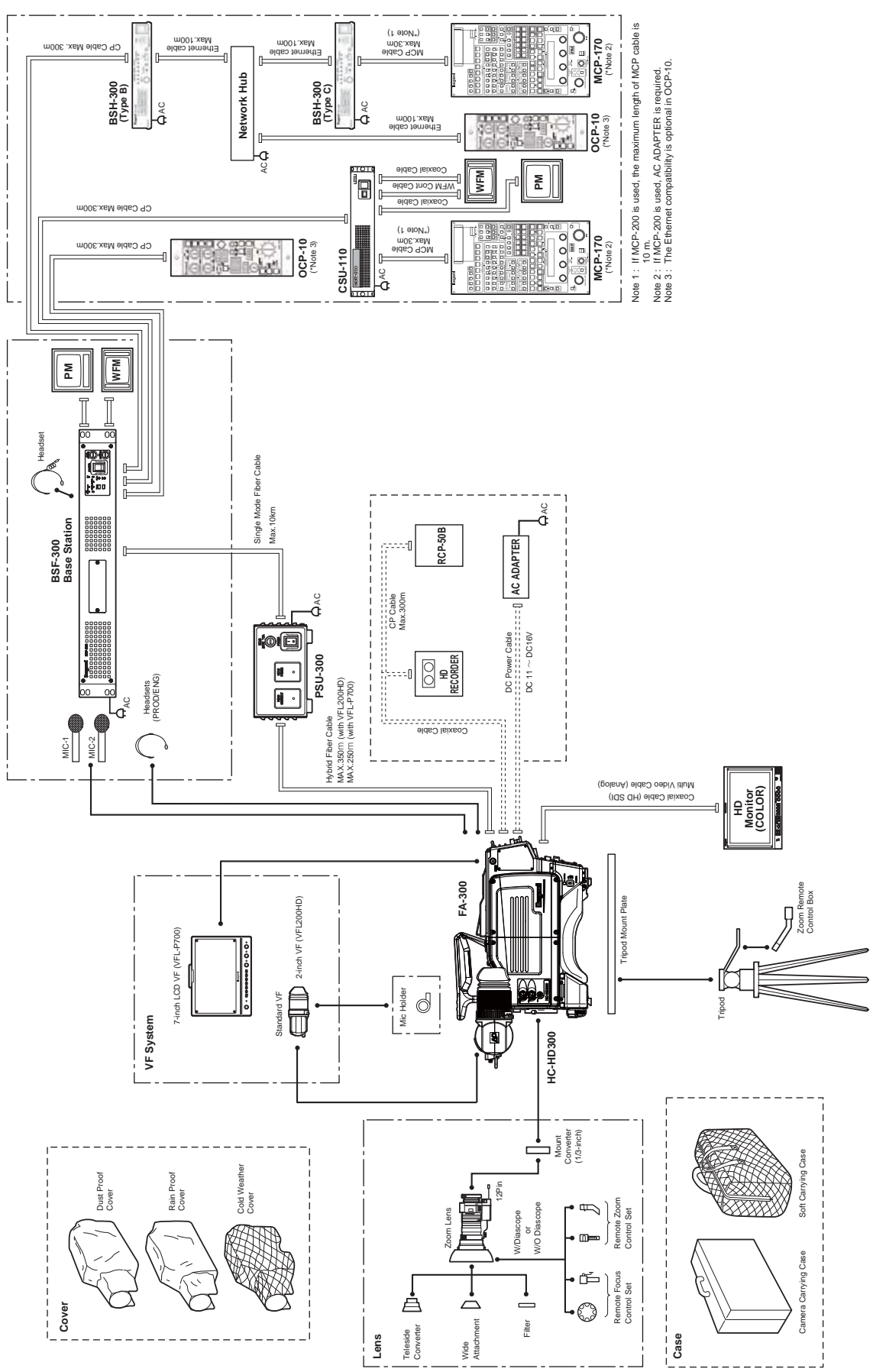

Note 1 : If MCP-200 is used, the maximum length of MCP cable is 0 m.
 Note 2 : If MCP-200 is used, AC ADAPTER is required.
 Note 3 : The Ethernet compatibility is optional in OCP-10.

NAME and FUNCTION



2.1 Camera and Viewfinder

This section explains the names and functions of the parts on the camera and viewfinder.

Camera Right View

2

NAME and FUNCTION

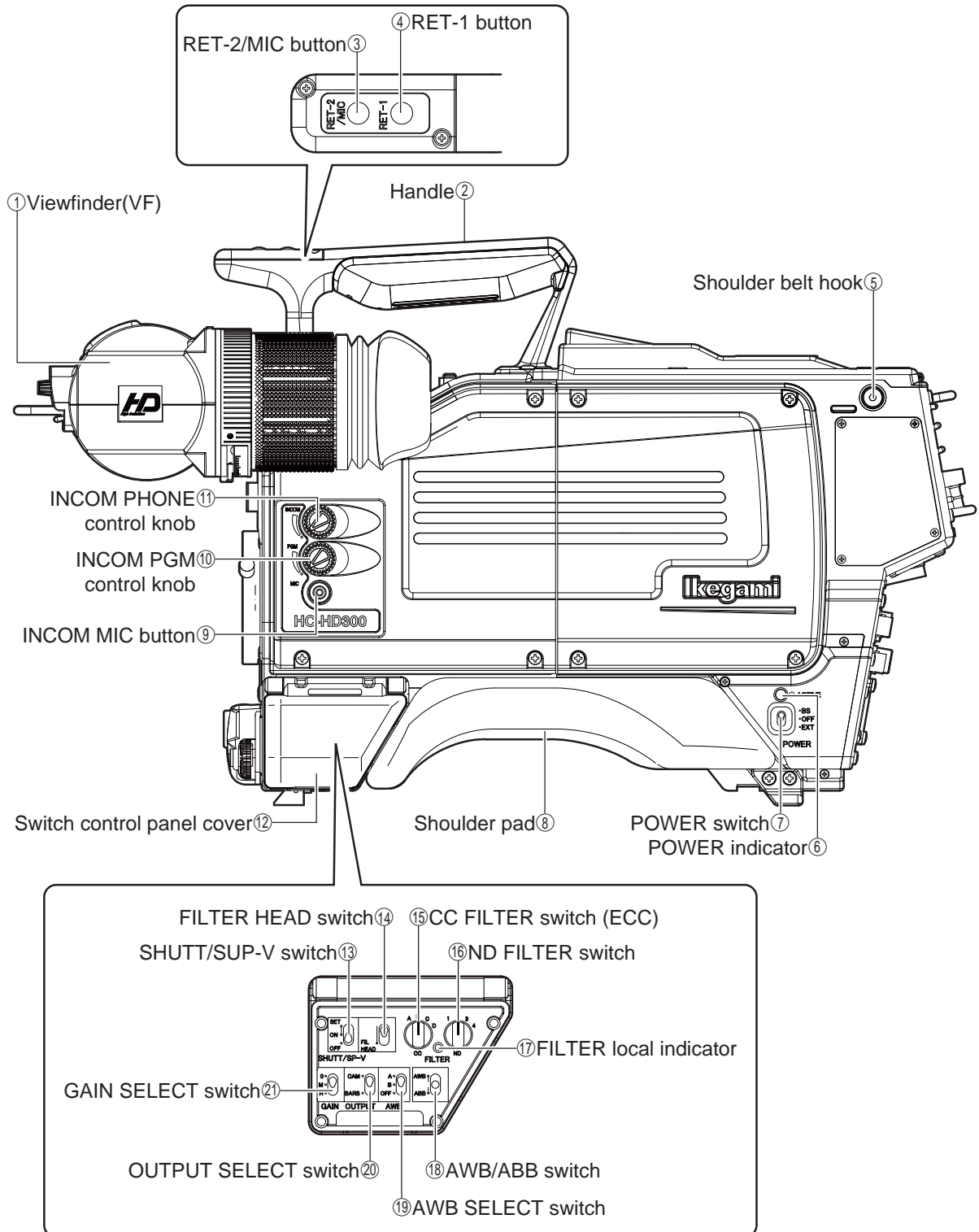

① Viewfinder (VF)

Displays camera image, return image, various characters and markers. 2" color viewfinder and 7" LCD studio viewfinder (optional) can be used.

② Handle

Grip this handle to carry the camera.

③ RET-2/MIC button

The RET-2 switch function or INCOM MIC switch function is allocated to this button. The button selects the function or turns ON/OFF the function.

● When set to RET-2

The viewfinder image is switched from the camera image to RET-2 image while this button is pressed.

● When set to INCOM MIC

Turns the intercom microphone ON/OFF when the INCOM FRONT VR SELECT switch on the rear of the camera is set to "ENG" or "PROD". The intercom microphone is turned ON while this button is pressed.

④ RET-1 button

Switches the viewfinder image from the camera image to RET-1 image. The viewfinder image is switched to the RET-1 image while this button is pressed.

⑤ Shoulder belt hook

Attaches the optional shoulder belt.

⑥ POWER indicator

Displays the status of power supply to the camera

Green LED : Indicates power is on

⑦ POWER switch

Turns ON/OFF the power of the camera or switches the power supply.

BS : Supplies power from the BS to the camera via fiber cable.

OFF : Turns power OFF.

EXT : Supplies power from external power supply. Set the POWER switch to EXT when power is supplied from external AC adapter through DC IN connector in the self-contained or VTR location operation.

⑧ Shoulder pad

Put the shoulder pad on your shoulder when you carry the camera on your shoulder.

⑨ INCOM MIC button

Turns the intercom microphone ON/OFF when the INCOM FRONT VR SELECT switch on the rear of the camera is set to "ENG" or "PROD". The intercom microphone is turned ON while this button is pressed.

⑩ INCOM PGM control knob

Controls the PGM volume of the intercom when the INCOM FRONT VR SELECT switch on the rear of the camera is set to "ENG" or "PROD".

⑪ INCOM PHONE control knob

Controls the volume of the intercom when the INCOM FRONT VR SELECT switch on the rear of the camera is set to "ENG" or "PROD".

⑫ Switch control panel cover

Protects the switch control panel.

Reference:

The functions are allocated using the menu. Refer to "5. CAMERA SETTINGS and ADJUSTMENT [Menu Configuration and content]" (P81) for setting.

⑬ SHUTT/SUP-V switch

Switches between the shutter speed and Super V function. The function working is displayed on the viewfinder.

- SET : Set Super V/Shutter mode.
- ON : Super V/Shutter mode is on.
- OFF: Shutter or Super V mode is off.

⑭ FILTER HEAD switch

Gives the camera the operational priority for the Electric Color Conversion (ECC) filter and Neutral Density (ND) filter settings. When the camera is connected to the BS and has the operational priority over the BS, an asterisk (*) will appear beside the selected ECC and ND filter on the viewfinder screen.

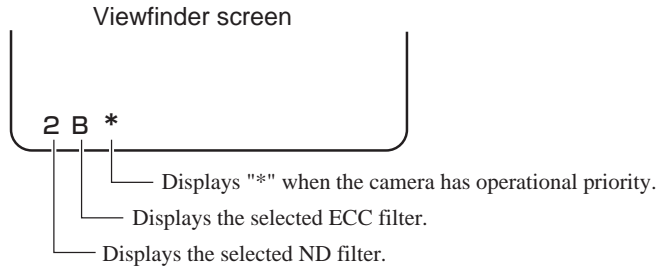

At the same time, the FILTER local indicator on the switch control panel lights, enabling you to select each filter using the CC FILTER switch (ECC) and ND FILTER switch.

⑮ CC FILTER switch (ECC)

Selects the ECC filter from the camera

- A : 3200K
- B : 4300K
- C : 6300K
- D : 8000K

⑯ ND FILTER switch

Selects the ND filter from the camera

- 1 : 100%
- 2 : 25%
- 3 : 6.2%
- 4 : 1.6%

⑰ FILTER local indicator

Lights when the ECC filter and ND filter are selected on the camera.

⑱ AWB/ABB switch

Automatically adjusts white balance, black balance, and black shading.

- AWB : By setting this switch to the AWB position, automatic adjustment of white balance starts. The adjusted value is stored in A-ch or B-ch memory.
- ABB : By setting this switch to the ABB position, automatic adjustment of black balance starts. The adjusted value is stored in memory.

⑲ AWB SELECT switch

Selects a memory for auto white balance. AWB settings can be stored in two memories, A-ch and B-ch, so they can be selectively used depending on different conditions.

- A : A-ch memory
- B : B-ch memory
- OFF: White balance adjustment is in the preset condition (3200K).

Reference:

The shutter speed is set from the menu. Refer to "5. CAMERA SETTINGS and ADJUSTMENT [Selecting Shutter Speed]" (P72) for setting.

⑳ OUTPUT SELECT switch

Switches between the picture shot by the camera and the color-bar signal.

CAM : Outputs the picture shot by the camera to the viewfinder or monitor.

BARS : Outputs the color-bar signal to the viewfinder or monitor.

㉑ GAIN SELECT switch

Selects the gain of the camera.

O : Normally selected (0dB value).

M : Gain value set by the menu is obtained. The set value is -6dB, -3dB, +3dB, +6dB
+9dB or +12dB.

H : Gain value set by the menu is obtained. The set value is -3dB, +3dB, +6dB, +9dB
+12dB or +18dB.

Camera Left View

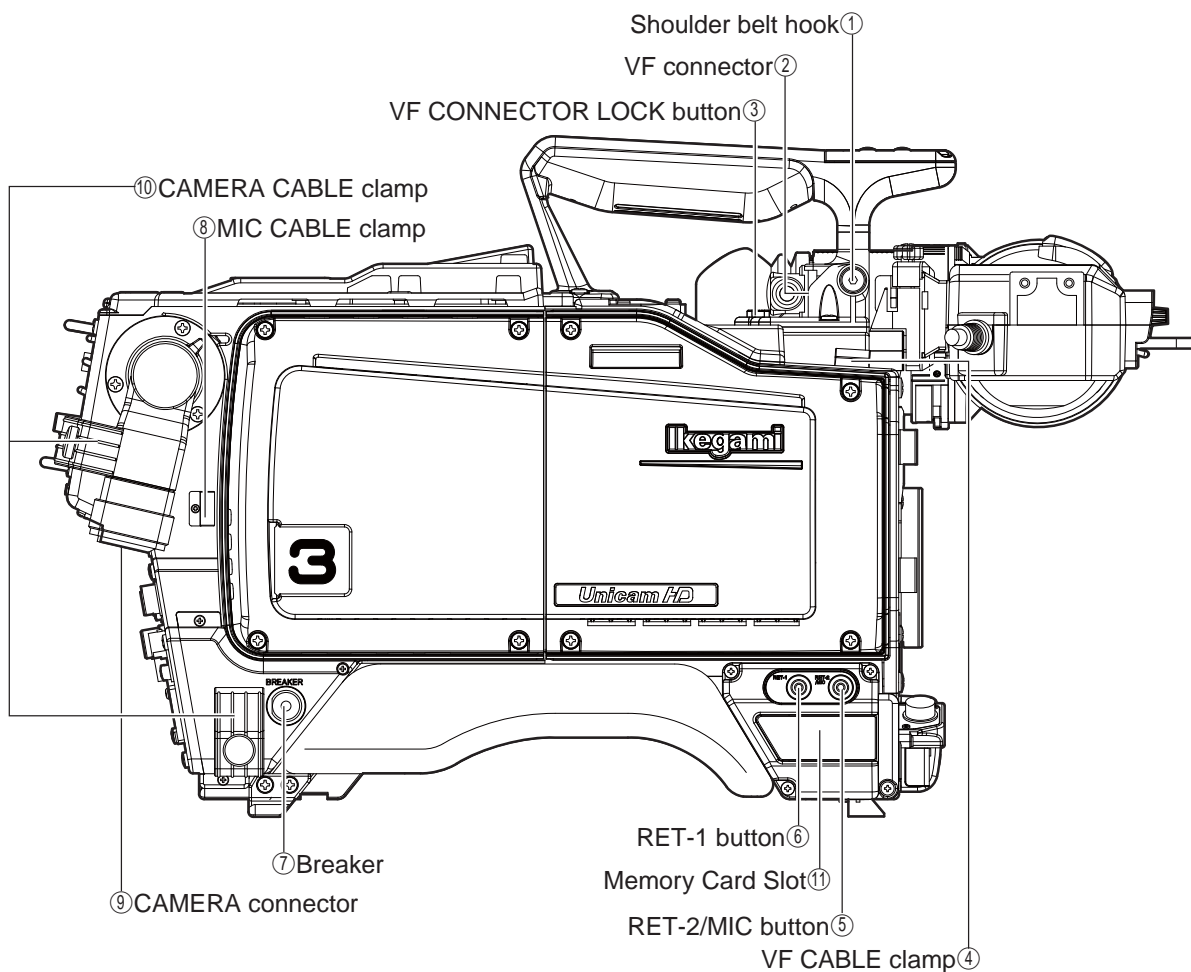

2

NAME and FUNCTION

① Shoulder belt hook

Attaches the optional shoulder belt.

② VF connector

Connects the VF cable

③ VF CONNECTOR LOCK button

Prevents the VF connector from being disconnected. To disconnect the VF cable, hold down this button.

④ VF CABLE clamp

Secures the VF cable.

⑤ RET-2/MIC button

The RET-2 switch function or INCOM MIC switch function is allocated to this button. The button selects the function or turns ON/OFF the function.

● When set to RET-2

The viewfinder image is switched from the camera image to RET-2 image while this button is pressed.

● When set to INCOM MIC

Turns the intercom microphone ON/OFF when the INCOM FRONT VR SELECT switch on the rear of the camera is set to "ENG" or "PROD". The intercom microphone is turned ON while this button is pressed.

⑥ RET-1 button

Switches the viewfinder image from the camera image to RET-1 image. The viewfinder image is switched to the RET-1 image while this button is pressed.

⑦ Breaker

A breaker (8A) for the camera

⑧ MIC CABLE clamp

Secures the microphone cable.

⑨ CAMERA connector

Connects the camera and BS with a fiber cable. It is compatible with NEUTRIK Optical CON DUO connector.

⑩ CAMERA CABLE clamp

Secures the fiber cable (9.2mm diameter).

⑪ MEMORY CARD slot

A slot for the memory card (SD card) used to store and recall setup data. When using the memory card, carefully insert the card in the slot until you hear a clicking sound.

When removing the card, carefully push in the upper part of the inserted card until you hear a clicking sound. The card will move up, making it possible to remove it.

When not using the memory card, attach the cover to prevent dust from accumulating.

When storing or retrieving data, the access indicator on the side of the the slot is lit. Do not remove the card if the access indicator is lit.

This could not only destroy the data on the card but also destroy camera data.

Reference:

The functions are allocated using the menu. Refer to "5. CAMERA SETTINGS and ADJUSTMENT [Menu Configuration and content]" (P81) for setting.

Reference:

Refer to "SAFETY PRECAUTIONS [Regarding the Fiber Connector and the Fiber Optic Cable]" (vii) for how to handle and secure the fiber cable.

Camera Front View

2

NAME and FUNCTION

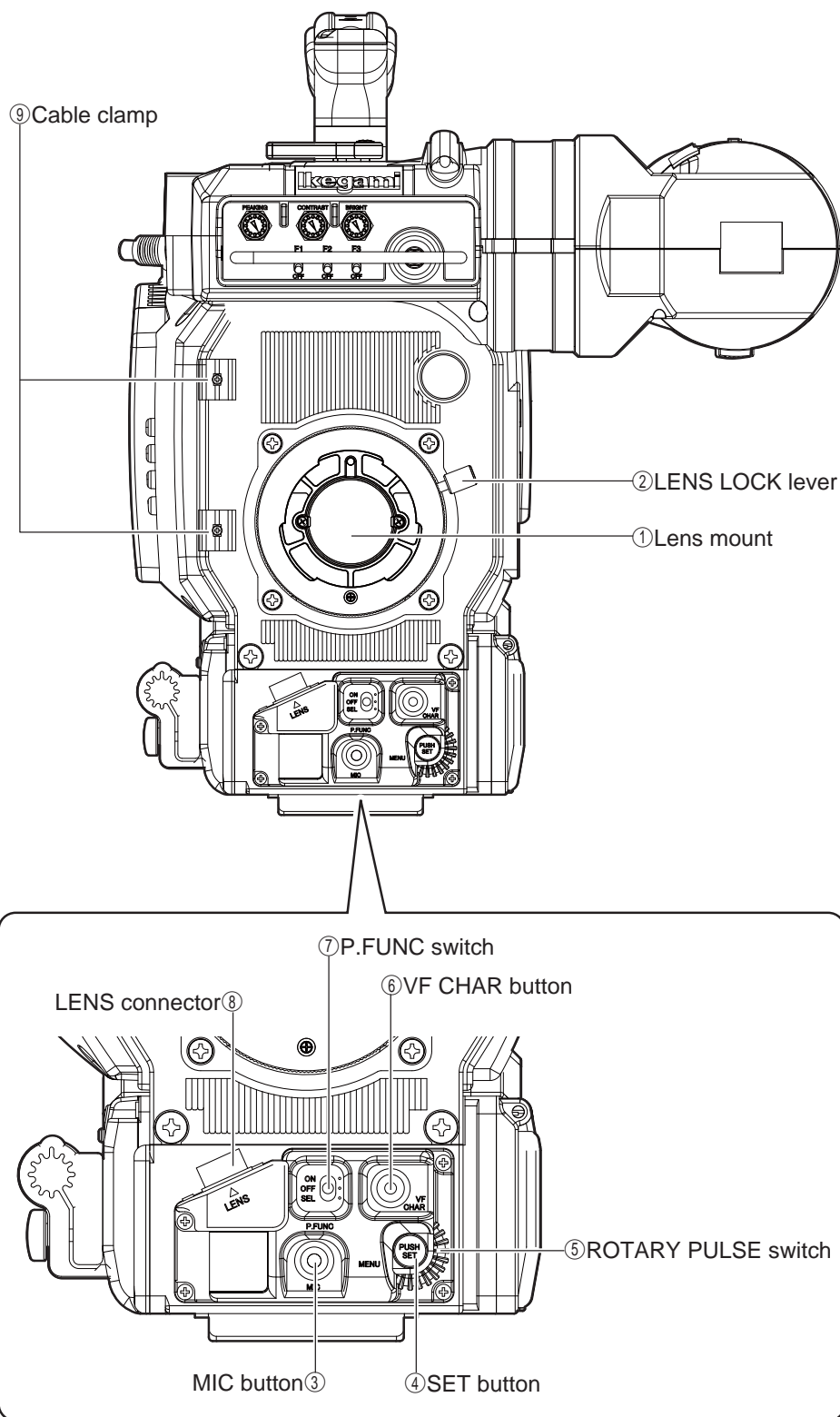

① **Lens mount**

Various 1/3" broadcast HD lenses can be mounted.

② **LENS LOCK lever**

Locks the lens mount. Turn the lens mount ring using this lever to secure the lens after the lens is inserted onto the lens mount.

③ **MIC button**

The intercom microphone is turned ON while this button is pressed.

④ **SET button**

Confirms the selected item or value on the menu.

⑤ **ROTARY PULSE switch**

Selects a shutter speed or other settings on the menu.

⑥ **VF CHAR button**

While this button is pressed, the camera status and various markers appear on the viewfinder. Also, using this button with the ROTARY PULSE switch will make the menu appear or disappear.

⑦ **P.FUNC switch**

Turns ON/OFF the functions allocated by the user. The user can allocate the following functions: IRIS CORR, IRIS CORR++, AUTO KNEE, SKIN DTL, SOFT DTL, and SCENE FILE

ON : Turns ON the allocated function.

OFF: Turns OFF the allocated function.

SEL: Set this switch to "SEL" when allocating the function.

⑧ **LENS connector**

Connects a 12-pin lens cable. It is compatible with BTA spec lenses..

⑨ **Cable clamp**

Secures the microphone cable and lens cable (pigtail cable).

Reference:

Refer to "5. CAMERA SETTINGS and ADJUSTMENT [Basic Operation of the Menu]" (P78) for how to open and close the menu.

Reference:

Refer to "5. CAMERA SETTINGS and ADJUSTMENT [Allocating Functions to the P.FUNC Switch]" (P76) for how to allocate functions to the P.FUNC switch.

Reference:

Refer to "7. SPECIFICATIONS [Lens Connector]" (P125) for the pin functions of the lens connector.

Camera Rear View

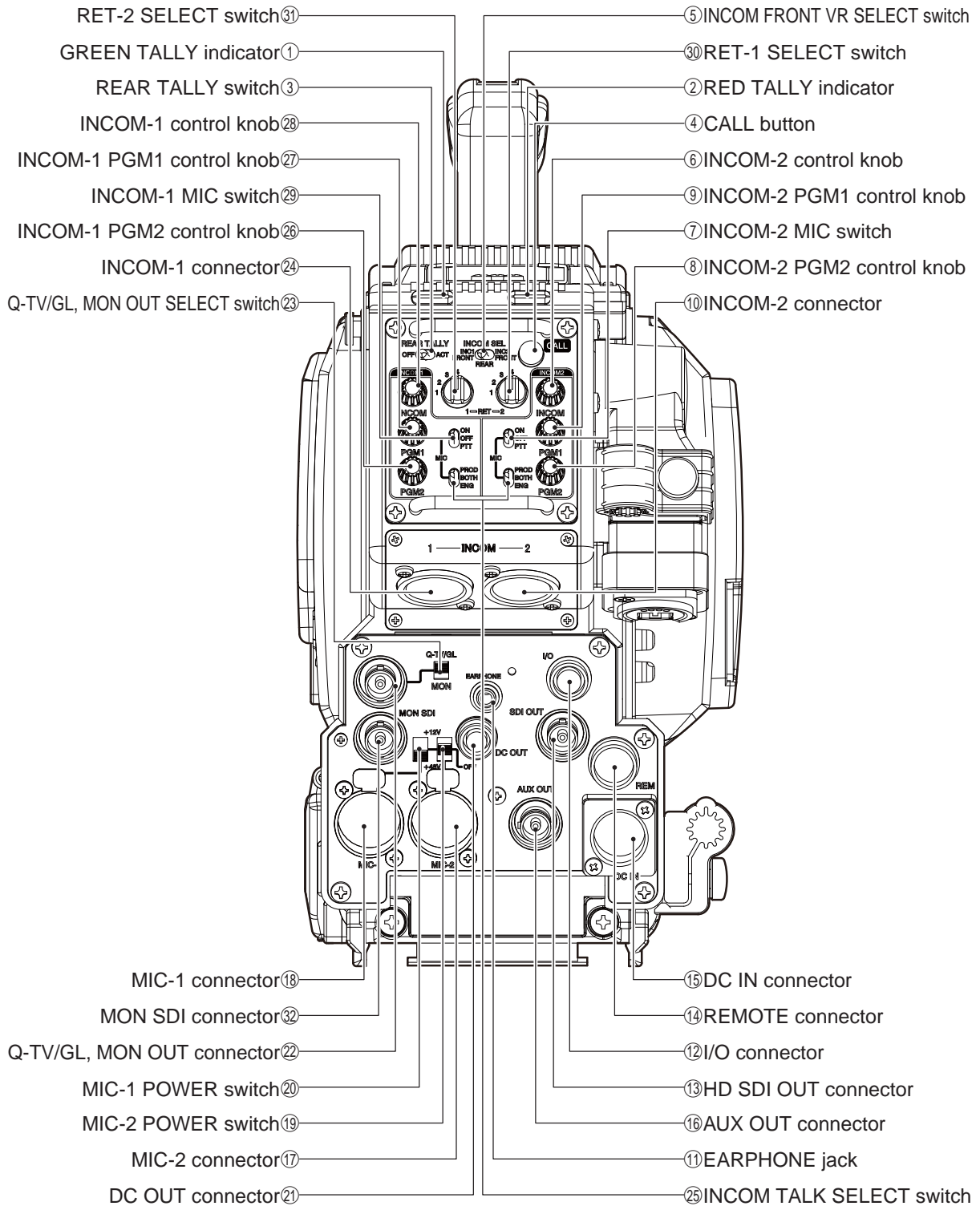

2

NAME and FUNCTION

① GREEN TALLY indicator

Lights when the GREEN TALLY signal is input to the BS.

② RED TALLY indicator

Lights when the RED TALLY signal is input to the BS. It also lights when the CALL button on the BS, or control panel is pressed.

③ REAR TALLY switch

Turns ON/OFF the GREEN TALLY and RED TALLY indicators.

ON : Activates lighting function of GREEN and RED TALLY indicators.

OFF: Deactivates lighting function of GREEN and RED TALLY indicators.

④ CALL button

Calls an operator. When this button is pressed, the RED TALLY lamps on the BS, and control panel light and a buzzer sounds.

⑤ INCOM FRONT VR SELECT switch

Specifies whether to use the right side controls (INCOM MIC switch, INCOM PGM control knob, and INCOM PHONE control knob) or the controls on the rear of the camera for controlling the intercom volume and push to talk functions.

INCOM-1 : Enables the use of the right side controls to control the INCOM-1 headset volume. The INCOM-2 headset volume is controlled by the controls on the rear of the camera.

OFF : Disables the use of the right side controls to control intercom. The volume is controlled by the controls on the rear of the camera.

INCOM-2 : Enables the use of the right side controls to control the INCOM-2 headset volume. The INCOM-1 headset volume is controlled by the controls on the rear of the camera.

⑥ INCOM-2 control knob

Controls the intercom volume of the channels allocated to the connector.

⑦ INCOM-2 MIC switch

Turns ON/OFF the INCOM-2 intercom microphone.

ON : Turns ON the intercom microphone.

OFF: Turns OFF the intercom microphone.

PTT: Turns ON the intercom microphone while this switch is pressed.

⑧ INCOM-2 PGM2 control knob

Controls the PGM2 volume of the INCOM-2 program intercom.

⑨ INCOM-2 PGM1 control knob

Controls the PGM1 volume of the INCOM-2 program intercom.

⑩ INCOM-2 connector

Connects the INCOM-2 intercom headset. It is compatible with XLR series or 110-type phone jack connectors.

⑪ EARPHONE jack

Connects the headset equipped with a mini plug. Voice can be heard when VTR is played back.

⑫ I/O connector

A multi-connector for input/output signals including GREEN/RED TALLY control output signals, RET-1/RET-2 control input signals, and RS-422 data control signals.

⑬ HD SDI OUT connector

Outputs the HD-SDI signal to an external system. It can be used as the main line signal connector when the camera is self-contained and it can be used as the MON OUT connector when the camera is connected to the BS.

⑭ REMOTE connector

Connects a remote control panel (OCP, MCP, or RCP) to send or receive various control signals when the camera is self-contained.

Reference:

Refer to "7. SPECIFICATIONS [I/O Connector]" (P134) for the pin functions of the I/O connector.

15 DC IN connector

Connects the AC adapter to supply +12V DC power to the camera.

16 AUX OUT connector

Outputs the Q-TV and VBS signals.

Select the Q-TV and VBS signals from the camera menu screen. The Q-TV signal output function only responds during BS operation.

17 MIC-2 connector

Connects microphone and input audio signals of line level.

18 MIC-1 connector

Connects microphone and input audio signals of line level.

19 MIC-2 POWER switch

Selects the type of power supplied to the microphone connected to the MIC-2 connection. The settings depend on the type of microphone used.

+12V : Supplies +12V AB power

OFF : Supplies no power. Applicable for a dynamic microphone or a microphone with built-in battery which requires no power supply

+48V : Supplies +48V Phantom power

20 MIC-1 POWER switch

Selects the type of power supplied to the microphone connected to the MIC-1 connection. The settings depend on the type of microphone used. Its settings are identical to the MIC-2 POWER switch.

21 DC OUT connector

DC 12V (0.5A) standard output connector for miscellaneous use (for example, a wireless mic receiver).

22 Q-TV/GL, MON OUT connector

Outputs the signal selected by the Q-TV/GL, MON OUT SELECT switch.

● When set to Q-TV/GL

Select the Q-TV and VBS signals from the camera menu screen. Outputs the analog video signal which is input to the Q-TV connector on the rear of the BS. The Q-TV, VBS video signal output function is available only when the camera is connected to the BS. Inputs a PS/S signal (tri-level sync) as external synchronization signal input (GENLOCK input). The external synchronization signal input is only available for the self-contained camera.

● When set to MON OUT

Outputs the monitor signal. Select the MON, SYNC signals from the camera menu screen.

23 Q-TV/GL, MON OUT SELECT switch

Selects the type of signal which is output from the Q-TV/GL, MON OUT connector.

24 INCOM-1 connector

Connects the INCOM-1 intercom headset. It is compatible with XLR series or 110-type phone jack connectors.

25 INCOM TALK SELECT switch

Selects a TALK line of INCOM.

PROD : Talks on Production intercom channel.

BOTH : Talks on both Production and Engineering channels.

ENG : Talks on Engineering intercom channel.

26 INCOM-1 PGM2 control knob

Controls the PGM2 volume of the INCOM-1 program intercom.

27 INCOM-1 PGM1 control knob

Controls the PGM1 volume of the INCOM-1 program intercom.

28 INCOM-1 control knob

Controls the INCOM-1 intercom volume.

⑳ **INCOM-1 MIC switch**

Turns ON/OFF the INCOM-1 intercom microphone.

ON : Turns ON the intercom microphone.

OFF: Turns OFF the intercom microphone.

PTT: Turns ON the intercom microphone while this switch is pressed.

㉑ **RET-1 SELECT switch**

Selects the input connected at the base station as the RET-1 signal sent to the camera.

㉒ **RET-2 SELECT switch**

Selects the input connected at the base station as the RET-2 signal sent to the camera.

㉓ **MON SDI connector**

Outputs the HD SDI signal for monitoring. MAIN, VF, or RETURN can be selected from the camera menu.

Viewfinder (VFL200HD)

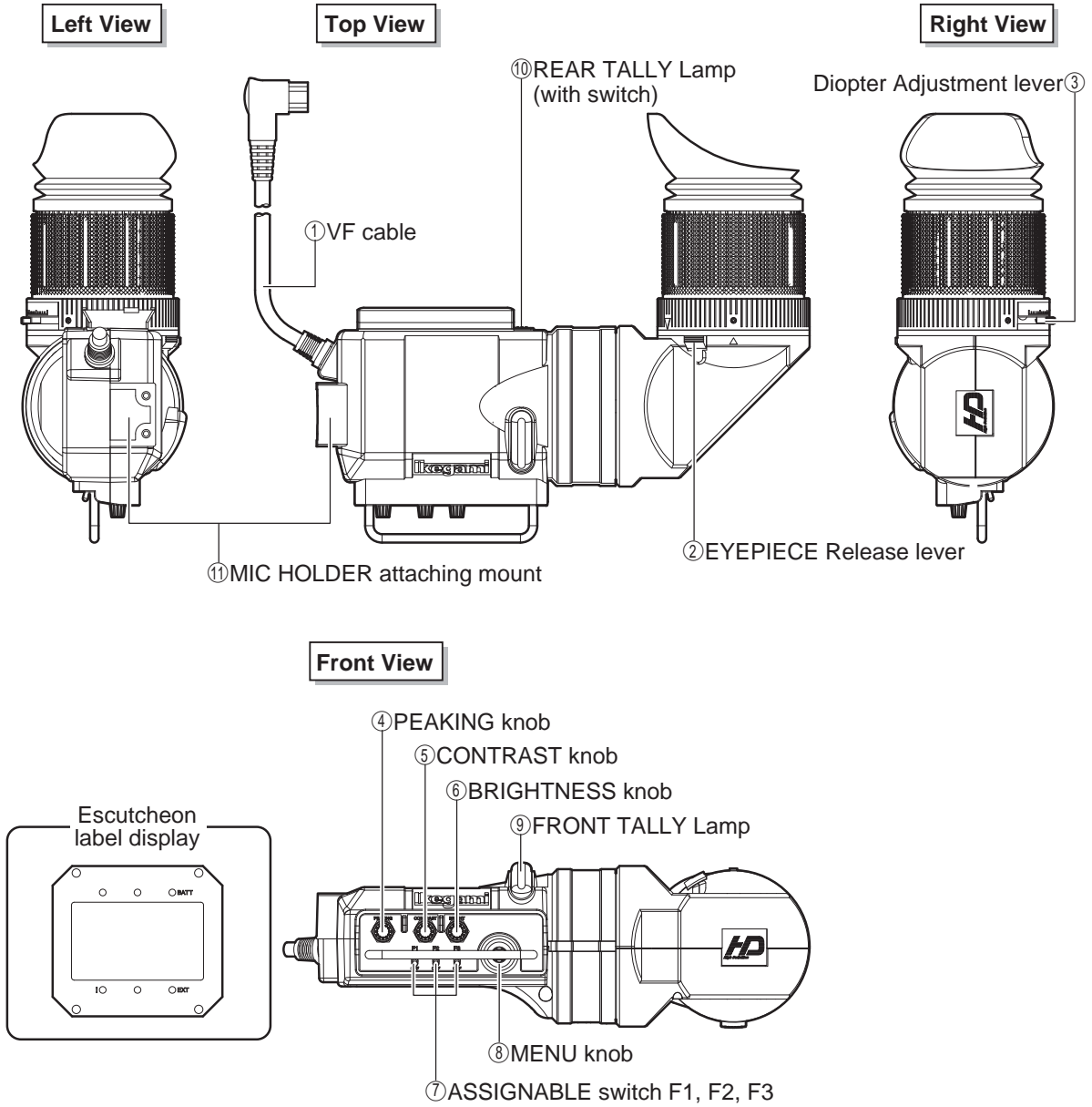

2

NAME and FUNCTION

① **VF cable**

Connects the viewfinder to the camera.

② **EYEPIECE Release lever**

Releases the eyepiece when the inside of viewfinder has to be cleaned.

③ **Diopter Adjustment lever**

Adjusts the focus so that images on the viewfinder can be sharpened according to the operator's eyesight. Adjustment is performed by sliding the lever to the left or right while pushing it in slightly.

④ **PEAKING knob**

Adjusts the PEAKING level to make images on the viewfinder sharper so that focus can be optimized. This adjustment has no effect on the output signal of the camera.

⑤ **CONTRAST knob**

Adjusts the contrast of images on the viewfinder. This adjustment has no effect on the output signal of the camera.

⑥ **BRIGHTNESS knob**

Adjusts the brightness of the image in the viewfinder. This adjustment has no effect on the output signal of the camera.

⑦ **ASSIGNABLE switch F1, F2, F3**

The toggle switches on the front side of viewfinder can be arranged to user preference in the menu settings.

⑧ **MENU knob**

Used to navigate the menu.

⑨ **FRONT TALLY Lamp**

Light is on when R-TALLY signal is input to from the camera. (During shooting videos or AIR ON)

⑩ **REAR TALLY Lamp (with switch)**

The REAR TALLY lamp is interlocked with the R TALLY indicator of the viewfinder, and lights during recording with the recorder or when R TALLY is input to various expansion devices. Since the REAR TALLY lamp serves as the switch, it can be turned ON/OFF by sliding.

⑪ **MIC HOLDER attaching mount**

Attaches an external microphone holder.

2.2 Displays in the Viewfinder

In addition to the LED indicators on the viewfinder, markers and characters are also displayed on the viewfinder screen. Details are provided below.

LED Indicator

- G TALLY : G TALLY indicator (Green).
- R TALLY : R TALLY indicator (Red).
- BATTERY : Lights when the battery voltage has fallen below the set value.
- ! : Lights when the camera settings are not standard. (Refer to Note.)
- EXT : Lights while the lens extender is being used.

Note:

The ! indicator lights when the following settings are made.

Switch/Function	Setting Status
AWB SELECT switch	OFF
KNEE MODE	MANUAL
SKIN DTL	ON
SHUTTER	ON
A. IRIS CORR	Other than OFF

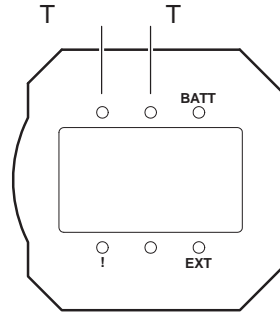

Center Marker, Safety Marker, Frame Marker

- The Center Marker is used to ascertain the center of the screen or align the camera horizontally and vertically.
- The Safety Markers are used to check the safe action area or safe title area. Switching between the action area and the title area is made from the menu.
- The Frame Marker is used to ascertain the frame of the image being shot.
- Aspect ratio (4:3/13:9/14:9/16:9) can be set to the Safety Markers and Frame Marker separately.

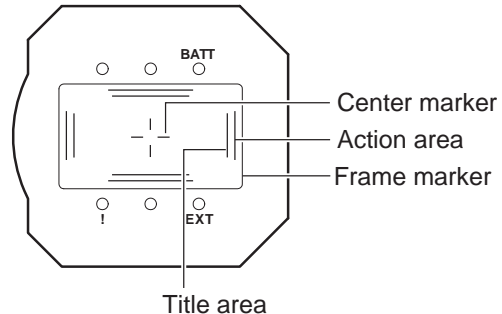

Reference:

Refer to "5. CAMERA SETTINGS and ADJUSTMENT [Menu Configuration and content]" (P81) for how to set each marker.

Zebra Indicator

The zebra signals are striped patterns that appear superimposed on the actual picture. There are two zebra signals: the zebra 1 signal which appears in the area where the video level of the subject is higher than the set value, and the zebra 2 signal which appears only in the area where the video level is the same as the set value. The zebra indicator is turned on/off by the assignable switch on front side of viewfinder. (The zebra function is assigned to the assignable switch F1 by default.)

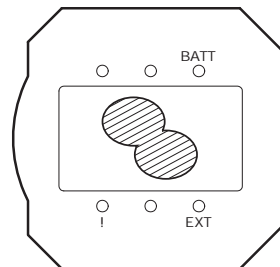

Reference:

Refer to "5. CAMERA SETTINGS and ADJUSTMENT [Menu Configuration and content]" (P81) for how to set the zebra signal.

Side Mask Function

When the camera output aspect ratio is set to 16:9, the picture on the viewfinder is displayed with a 16:9 aspect ratio. In consideration of converting to a 4:3 picture, the contrast of the picture outside the frame marker area can be adjusted. The side mask is displayed when the frame marker is set to the following ratio:

- With 16:9 mode: 4:3, 13:9, 14:9, 15:9
- With 4:3 mode: 13:9, 14:9, 15:9, 16:9

Reference:

Refer to "5. CAMERA SETTINGS and ADJUSTMENT [Menu Configuration and content]" (P81) for how to set the side mask.

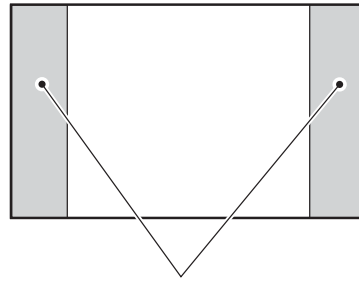

Brightness of the picture outside the frame marker can be adjusted.

Display Mode

The display mode sets the markers and characters to be displayed in the viewfinder.

Reference:

The display mode is set from the menu. Refer to "5. CAMERA SETTINGS and ADJUSTMENT [Menu Configuration and content]" (P81).

Viewfinder Display

■ **Status Display**

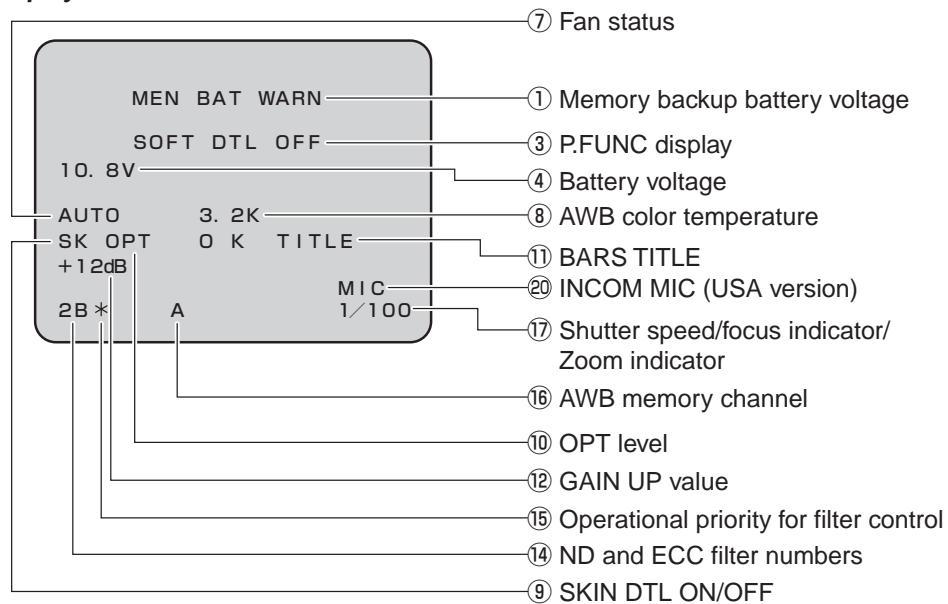

■ Warning Display

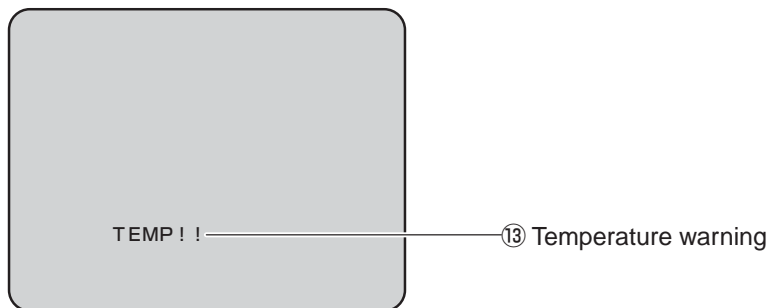

■ Auto Setup Display

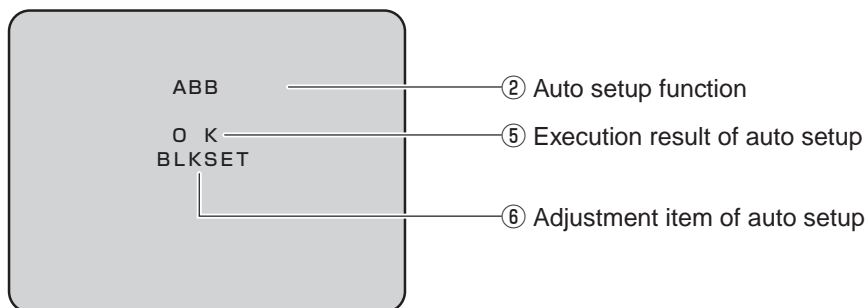

■ Return Video Channel Display

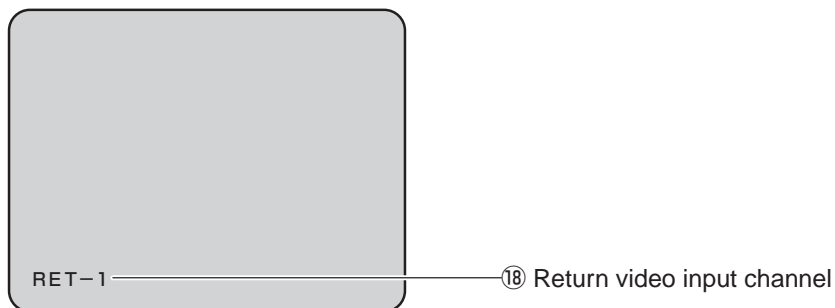

① Memory backup battery voltage

The warning message is displayed for 5 seconds when the voltage of the backup battery in the MPU module has dropped.

② Auto setup function

Executing auto setup function is displayed.

"AWB"

"ABB" etc.

③ P.FUNC display

Function assigned to the P.FUNC switch is displayed with its ON/OFF status

"IRIS+ CORR OFF"

"AUTO KNEE ON"

"SCENE-1 ON" etc.

④ Battery voltage

The present voltage is displayed flashing when the battery voltage has dropped below the set value. Battery voltage is set from the menu "BATTERY WARNING."

⑤ Execution result of auto setup

Execution result of auto setup (AWB and ABB, etc.) is displayed.

OK : Auto setup has been completed.
 NG : Auto setup was not completed.
 STOP : Auto setup was discontinued.
 LEVEL OVER : Input signal level is too high.
 LEVEL UNDER : Input signal level is too low.
 CHG FILTER : Optical filter is not appropriate.

⑥ Adjustment item of auto setup

The item to which adjustment is being made is displayed during auto setup.

"FLARE GAMMA GAIN"

"PED"

"IRIS" etc.

⑦ Fan status

The fan status is displayed.

AUTO : Fan is in the AUTO mode.

Displayed when the VF CHAR button is pressed.

SLOW : Fan is in the SLOW mode.

Displayed when the VF CHAR button is pressed.

QUIET : Fan is in the QUIET mode.

Displayed when the VF CHAR button is pressed.

STOP : Fan is in the STOP mode.

Displayed when the VF CHAR button is pressed.

FAN!! : Displayed flashing when the fan has stopped abnormally.

⑧ AWB color temperature

The color temperature stored in A-ch or B-ch memory is displayed for 2 seconds when the AWB/ABB switch is operated. (Selection between A-ch and B-ch is made by the AWB SELECT switch.) The AWB color temperature is also displayed when the FILTER switch is operated.

⑨ SKIN DTL ON/OFF

"SK" is displayed when the SKIN DTL function is ON.

⑩ OPT level

Optical signal level of the fiber cable is displayed when the BS is connected to the camera. When the optical signal level is normal, "OPT OK" is displayed for 2 seconds.

⑪ BARS TITLE

The bar title is displayed when the color bar is output.

⑫ GAIN UP value

The set Gain is displayed. "0dB" is displayed only when the GAIN SELECT switch is operated.

⑬ Temperature warning

This warning is displayed when the temperature of the inside of the camera is high.

⑭ ND and CC filter numbers

ND	1 100%	2 25%	3 6.2%	4 1.6%
ECC	A 3200K	B 4300K	C 6300K	D 8000K

⑮ Operational priority for filter control

"*" is displayed when the camera has the operational priority for the filter control.

⑯ AWB memory channel

The memory selected by the AWB SELECT switch is displayed.

A : A-ch memory

B : B-ch memory

O : White balance adjustment is in the preset condition (3200K).

⑰ Shutter speed/focus indicator/zoom indicator

The shutter speed or focus, zoom position is displayed.

⑱ Return video input channel

Input channel for return video is displayed.

RET-1 : Return video 1 is selected.

RET-2 : Return video 2 is selected.

RET-3 : Return video 3 is selected.

RET-4 : Return video 4 is selected.

⑲ INCOM MIC (USA version)

This is displayed when "MIC" is selected using the RET-2/MIC button.

INSTALLATION and CONNECTION

3

3.1 Preparation

Product Use Environment

Please read "SAFETY PRECAUTIONS" (iv) described at the beginning of this manual for precautions on use of this product.

Make sure the Power Switch is OFF

Please make sure that the power switch is "OFF" before connecting the camera and peripheral equipment such as the BS.

Camera right view

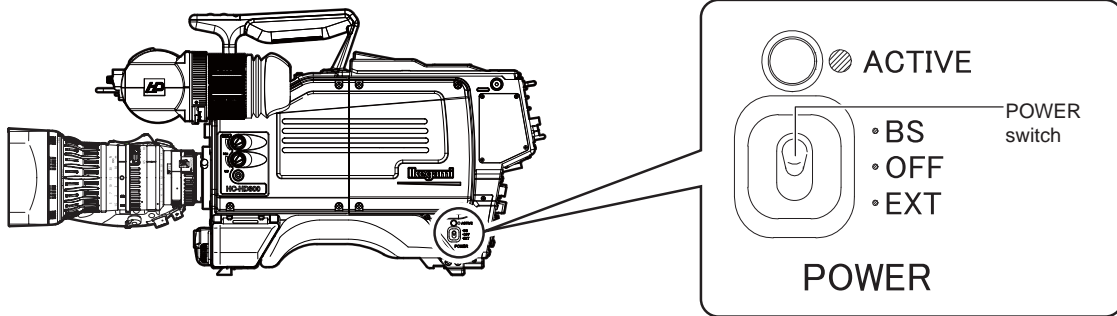

BS front view

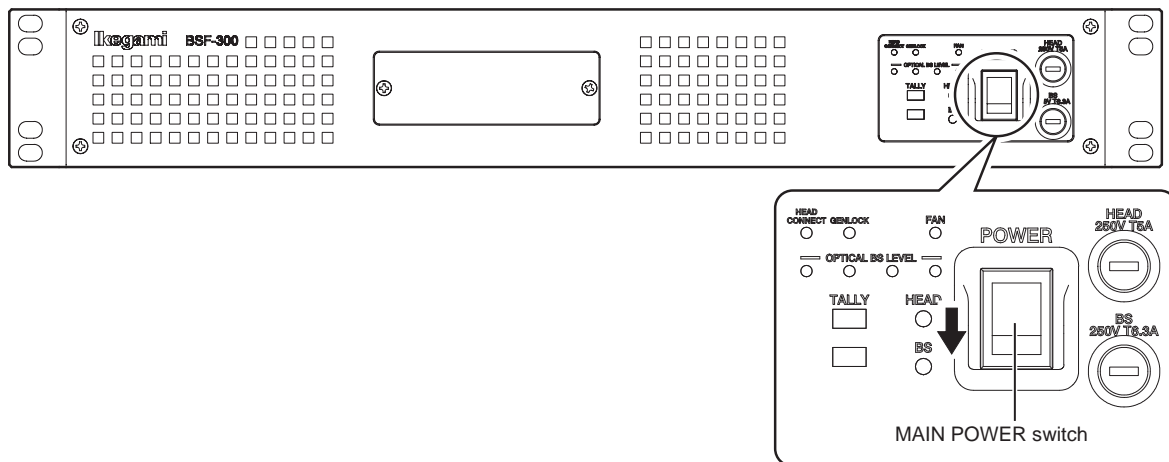

Connection Examples for Typical Operating Systems

Not only can the HC-HD300 be used stand-alone for video location operation, but it can also be used in various operating systems in studio and in field as a system camera in combination with peripheral equipment such as the BS. This section shows connection examples of typical operating systems. Please refer to these examples when you connect the camera, shooting equipment, and peripheral equipment.

Connection Example for Stand-Alone/HD RECORDER Location Operation

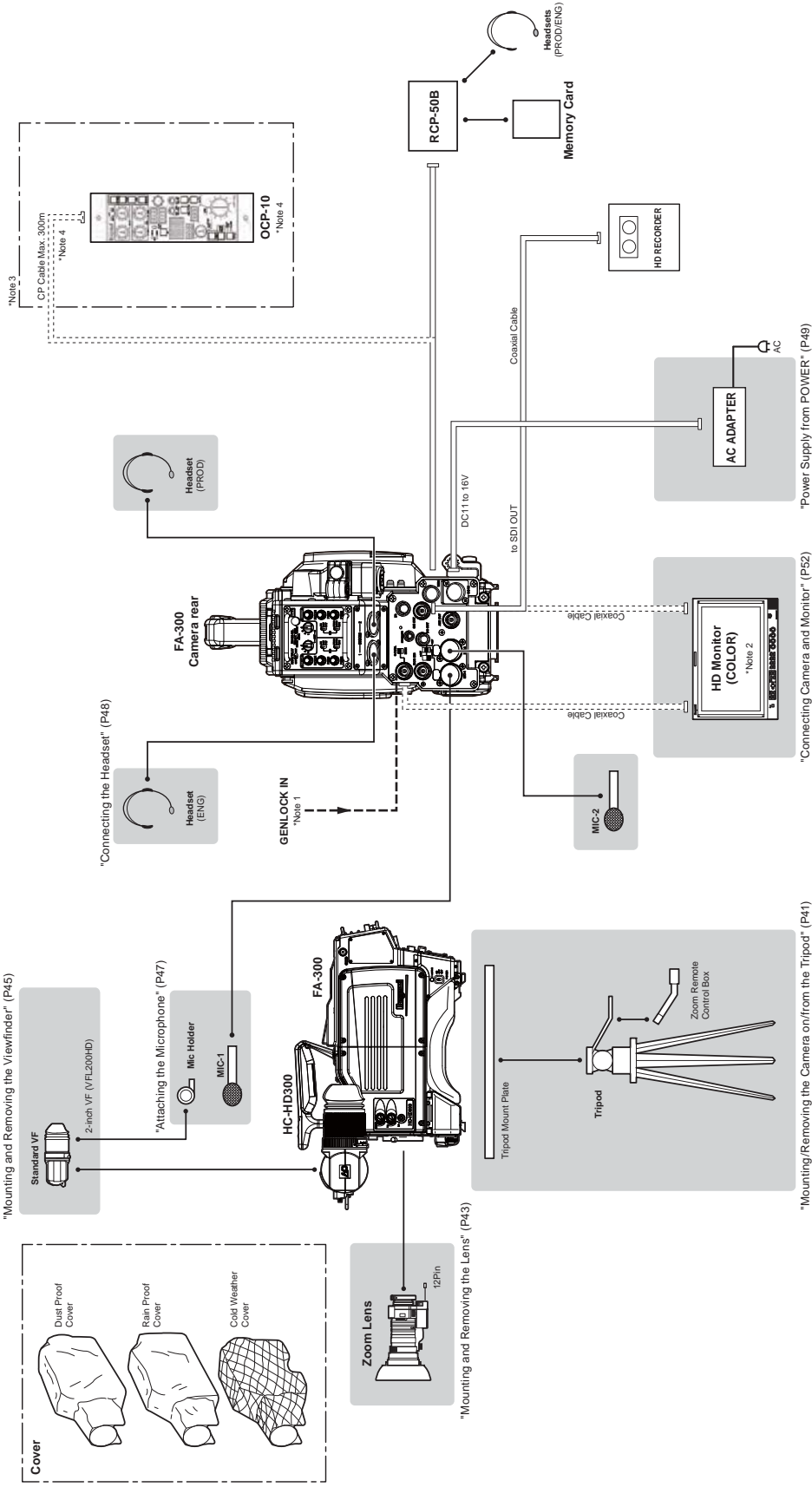

Note 1 : Only applicable for the self-contained system operation
 Note 2 : Selection between Q-TV/GL and MON OUT is made by the switch.
 Note 3 : OCP and MCP can be directly connected to the camera only in the self-contained system operation.
 Note 4 : The maximum length of CP cable depends on the OCP. Please refer to the operation manual of respective OCP.

■ Connection Example for Studio Operation (Using BSF-300)

For how to connect a PM, WFM, MCP, OCP, or CSU which is to be connected to BSF-300, refer to the instruction manuals attached to each equipment.

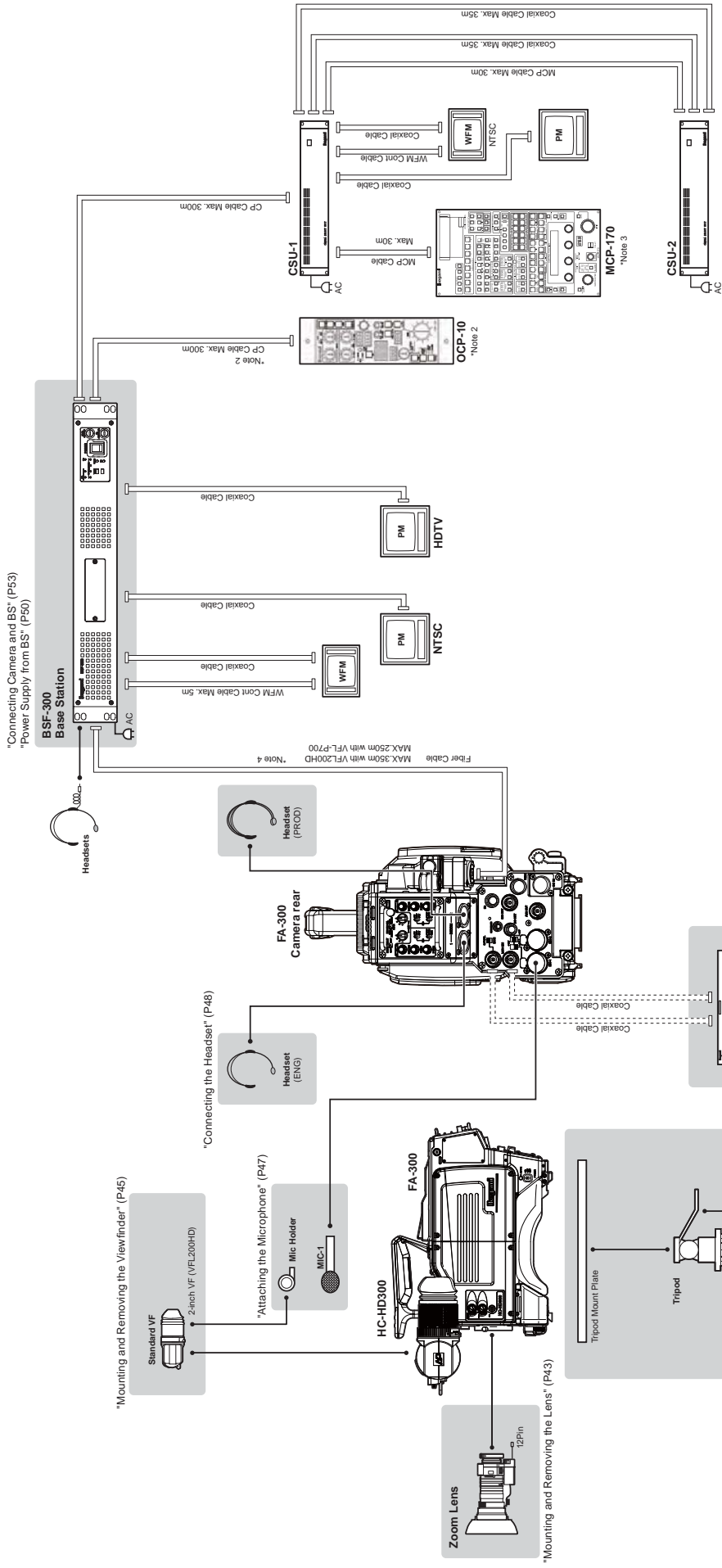

Connecting Camera and BS (P53)
 Power Supply from BS (P50)

Mounting and Removing the Viewfinder (P45)

Connecting the Headset (P48)

Attaching the Microphone (P47)

Mounting and Removing the Lens (P43)

Connecting Camera and Monitor (P52)

Mounting/Removing the Camera on/from the Tripod (P41)

Note 1 : Selection between Q-TV/GL and MON OUT is made by the switch.
 Note 2 : If OCP-200 is used, the maximum length of CP cable is 80m.
 Note 3 : If MCP-200 is used, AC Adapter is required.
 Note 4 : If an optical fiber cable is extended for 200m or more, an optional optical fiber cable and connection adapter (NAO2S-H1W-A) may be needed.

■ Connection example for Long-Distance Transmission Operation

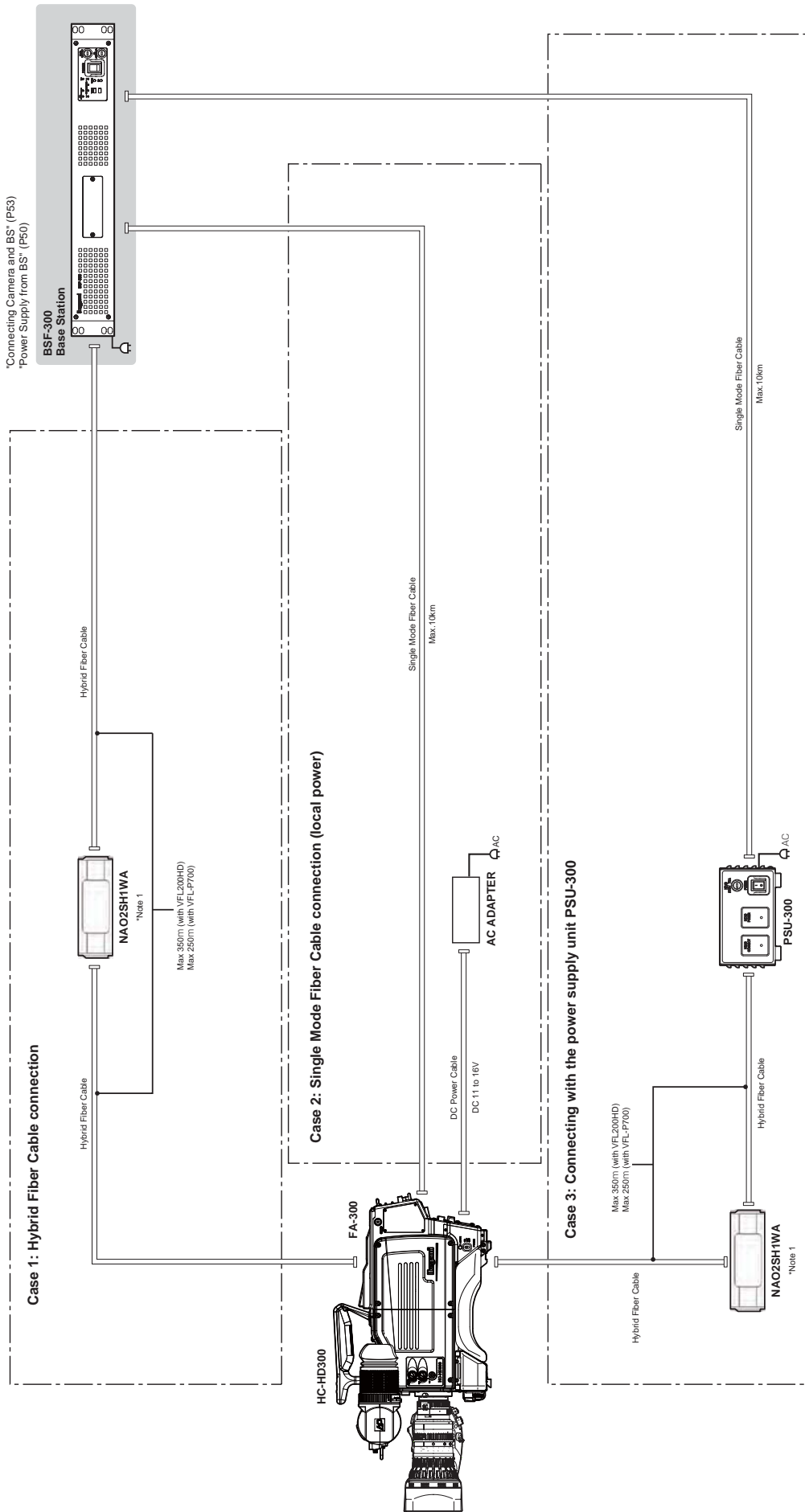

Note 1 : If an optical fiber cable is extended for 200m or more, an optional optical fiber cable and connection adapter (NAO2S-H1W-A) may be needed.

3.2 Camera and Peripheral Installation and Connection

Mounting/Removing the Camera on/from the Tripod

■ Mounting the Camera on the Tripod

This section explains how to mount the camera on a tripod. A number of different kinds of tripods are available to suit different applications and purposes. For details on the tripod, refer to the instructions accompanying the tripod to be used. Mounting on a VIDEO-18 will be described below as an example.

1 Loosen the lock knobs and extend the tripod legs.

Adjust the height of the tripod to the desired height.

2 Tighten the lock knobs to lock the tripod legs.

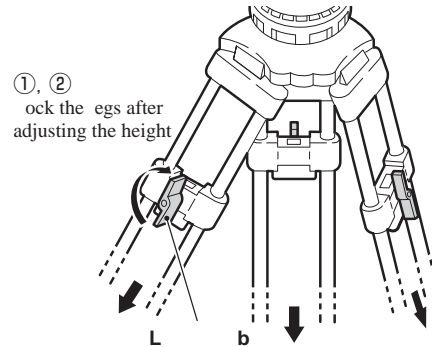

3 Make sure that the tilt lock and pan lock are locked.

If they are not locked and loose, tighten them.

CAUTION:

Be sure to tighten the lock knobs before mounting the camera on a tripod. If the tripod is unstable, the camera might fall when it is mounted on the tripod, resulting in a damage to the camera or injury to the user.

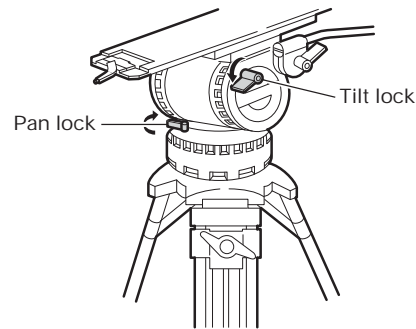

③ Make sure the tilt lock and pan lock are locked.

4 Insert the rear wedge of the camera into the groove of the tripod mount plate and move it backward slightly.

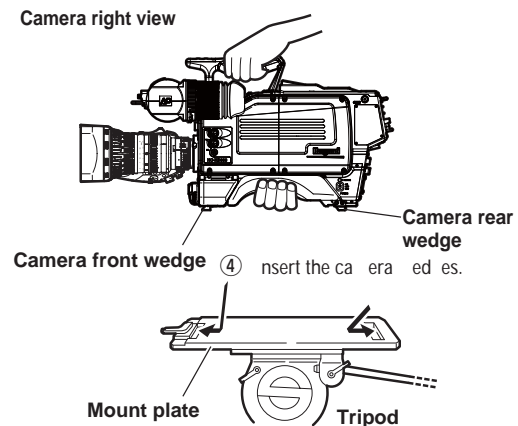

- 5** After inserting the front wedge of the camera, tighten the lock lever until the camera is completely fixed.

Turn the lock lever until it clicks. You will hear a click sound when the lock lever is locked.

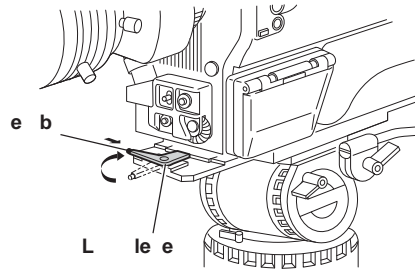

- ⑤ Tighten the lock lever until the camera is completely fixed.

- 6** Make sure that the camera is fixed to the tripod mount plate completely and does not wobble.

CAUTION:

Be sure to mount the camera on a tripod securely, or the camera might fall and get damaged and you can be injured.

- 7** Loosen the tilt lock and pan lock and adjust the pan and tilt of the camera.

Setting the pan brake and tilt brake to a low number will minimize friction and ensure smooth movement.

- 8** After positioning the camera to the desired pan and tilt, tighten the tilt lock and pan lock to lock the camera.

Camera right view

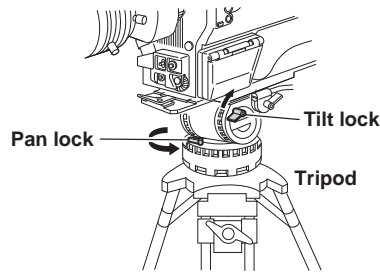

- ⑦ Loosen the tilt lock and pan lock and adjust the pan and tilt of the camera.

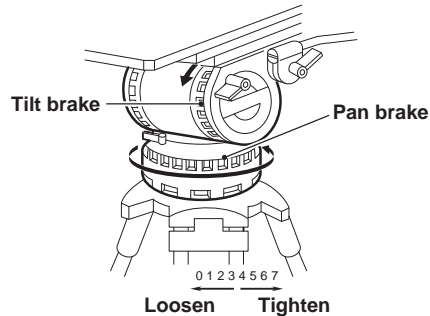

- ⑧ Tighten the tilt lock and pan lock to lock the camera.

■ Removing the Camera from the Tripod

This section explains how to remove the camera from the tripod.

- 1** Press the red button on the lock lever to unlock the camera.

Be sure to hold the handle while pressing the button to prevent the camera from falling.

- 2** Lift the camera and remove the wedges from the tripod mount plate.

Mounting and Removing the Lens

■ Mounting the Lens

This section explains how to mount the lens to the camera.

Be sure to place the camera on a tripod or on a flat, level, stable surface when you mount the lens. The lens can be mounted to the HC-HD300 using the BTA mounting method.

- 1 Before proceeding any further, remove the lens cap by pushing up the lens lock lever.

- 2 Align the pin of the lens with the notch of the camera lens mount, and horizontally insert the lens into the camera lens mount.

Support the lens with your hand to prevent it from falling.

- 3 Secure the lens to the camera.

Push down the lens lock lever to secure the lens to the camera. Make sure there is no play.

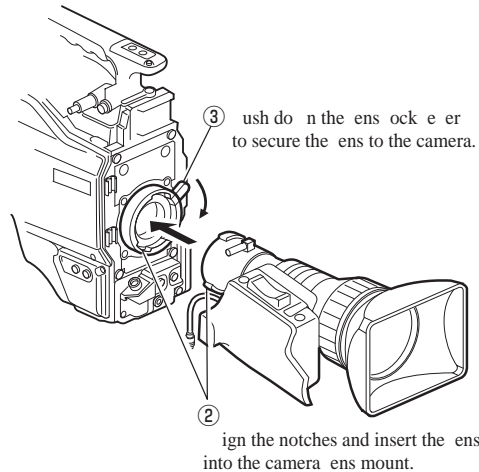

- 4 Connect the pigtail cable to the lens connector.

Align the pins on the pigtail cable with the lens connector and push until it is locked.

- 5 Secure the pigtail cable with the cable clamps to remove any slack.

CAUTION:

Do not hold the lens housing to support the entire camera. An excessive force applied to the mount will cause damage.

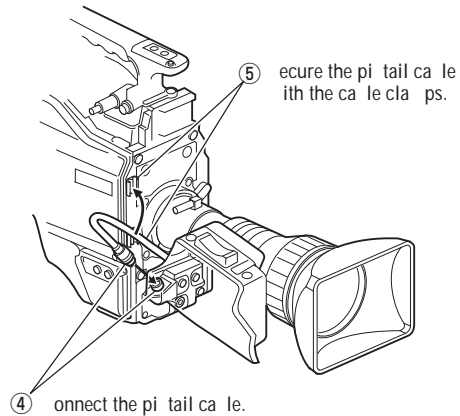

■ Removing the Lens

This section explains how to remove the lens.

Be sure to place the camera on a tripod or on a flat, level, stable surface when you remove the lens.

- 1** Disconnect the pigtail cable from the lens connector.
Hold the connector of the pigtail cable and pull to unlock and release it from the lens connector.

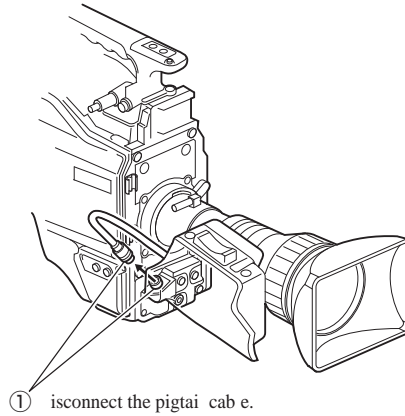

- 2** Remove the lens from the camera.
Rotate the lens lock lever Counter-clockwise to the end stop and remove the lens from the camera horizontally. Support the lens with your hand to prevent it from falling.

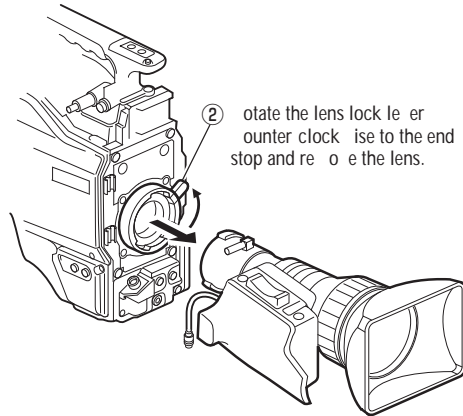

- 3** Remove the pigtail cable from the cable clamps.
- 4** Put the lens cap on the lens to protect the lens from dirt and scratches.
Put the lens cap on the camera if no other lens is to be mounted at this time.

Mounting and Removing the Viewfinder

■ Mounting the Viewfinder

This section explains how to mount the viewfinder (VFL200HD) to the camera.

- 1** Make sure the camera power switch is OFF.
If the power switch is set to BS or EXT, turn it OFF.
- 2** Tilt the viewfinder eyepiece upward 90 degrees.
- 3** Set the VF slide lock CCW. Slide the rail on the rear of the viewfinder into the guide on the front of the camera from the left-hand side.

Slide the viewfinder until it clicks into position. When the viewfinder is locked to the camera by the lock pin, it clicks.

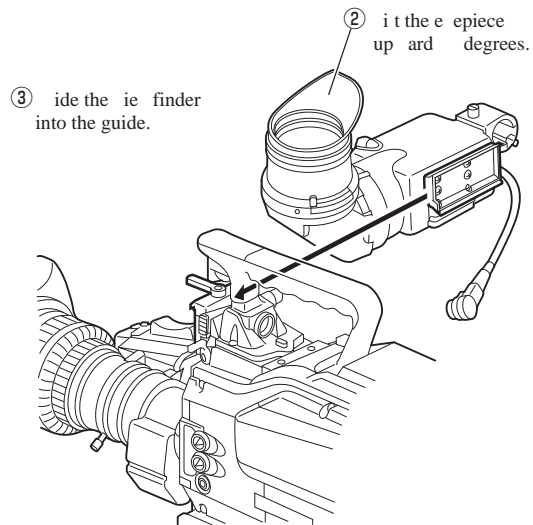

- 4** Set the VF slide lock CW to lock the viewfinder in position.
- 5** Connect the viewfinder cable to the viewfinder connector on the camera handle.

Align the pins on the viewfinder cable with the viewfinder connector and push until the connector lock button clicks.

CAUTION:

Be careful not to catch your fingers in the lock lever or guide-rail when attaching the viewfinder. Take caution to avoid injury.

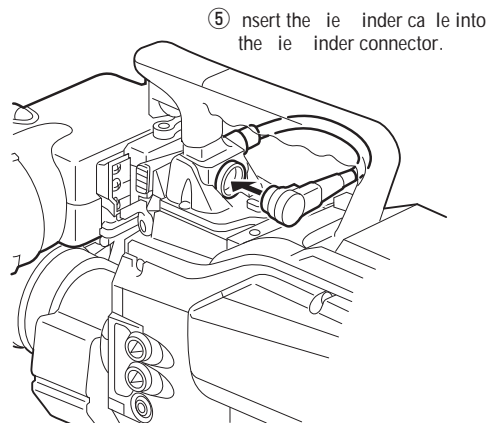

5 Adjust the viewfinder position.

● Adjust the left and right positions of the viewfinder

Turn the left-right lock lever on the camera counterclockwise to unlock the viewfinder. Move the viewfinder left and right to the desired position and lock.

● Adjust the front and back positions of the viewfinder

Loosen the front-back lock lever on the camera to unlock the viewfinder. Move the viewfinder back and forth to the desired position and lock.

● Adjust the eyepiece angle

Move the eyepiece to a proper position so that the image on the viewfinder is visible. The eyepiece can be rotated 160 degrees upward and 90 degrees downward. Adjust the eyepiece angle in accordance with the camera angle.

● Adjusting the eyepiece angle

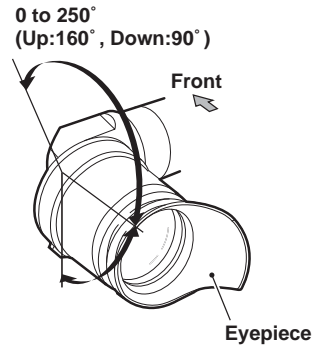

■ Removing the Eyepiece

This section explains how to remove the eyepiece from the viewfinder.

- 1 Pull the eyepiece release lever and rotate the eyepiece in the direction shown in the figure.

The eyepiece will be unlocked.

- 2 Pull out the eyepiece.

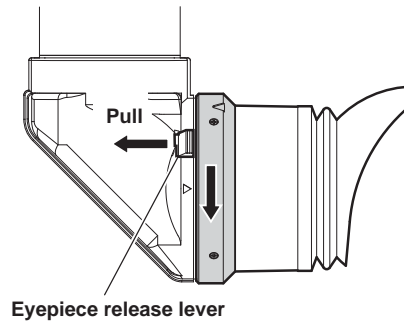

■ Attaching the Eyepiece

This section explains how to attach the eyepiece to the viewfinder.

- 1 Align \triangle mark on the viewfinder with \triangle mark on the eyepiece and insert the eyepiece into the viewfinder.

- 2 Rotate the eyepiece in the direction shown in the figure.

Rotate the eyepiece until it clicks. You will hear a click sound when the eyepiece is locked to the viewfinder.

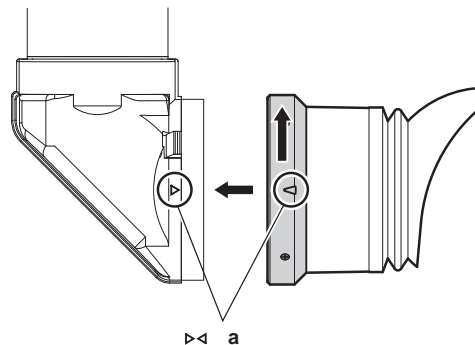

Attaching the Microphone

This camera is equipped with two microphone channels (MIC-1 and MIC-2). Please select depending on the operation. This section explains how to attach a microphone to the microphone holder on the viewfinder.

Note:

The microphone holder is optional.

- 1** Make sure the microphone holder is attached to the viewfinder.
If the microphone holder is not attached, attach it to the microphone holder attaching mount of the viewfinder.
- 2** Loosen the screw on the microphone holder to open it.
- 3** Put the microphone in the opened microphone holder and tighten the screw to secure it in place.
- 4** Connect the microphone cable to the MIC-1 connector on the rear of the camera.
(This step is the same if the MIC-2 connector is used.)
- 5** Secure the microphone cable with the cable clamp to remove any slack.

Reference:

Power supply methods depend on the type of microphone used. Be sure to set the power supply method for the microphone before the power is supplied to the camera. Refer to "4. OPERATION [4.2 Switch Position Check]" (P58) for how to select the power supply.

For details on the microphone, refer to the instructions accompanying the microphone to be used.

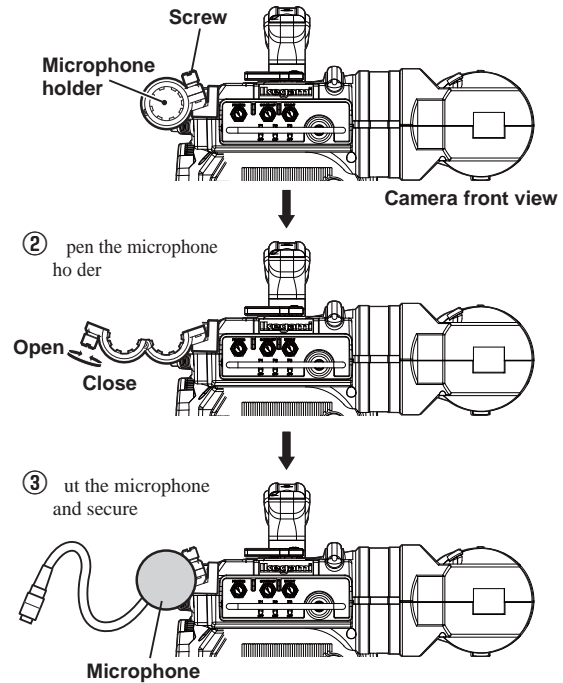

Connecting the Headset

Two intercom lines (1 and 2) can be connected to the HC-HD300. Please select the engineer intercom or producer intercom depending on the use. This section explains how to connect the engineer intercom to the camera.

- 1 Plug the headset connector into the INCOM-1 connector on the camera.
- 2 Turn the INCOM-1 MIC switch ON.

Note:

The ENG INCOM connector and PROD INCOM connector are compatible with the XLR series and 110-type phone jack connector.

CAUTION:

Do not set the volume of the intercom receiver to near maximum level from the beginning. Setting the volume too high with the intercom headset on your ears may damage your eardrums. Excessive sound pressure from the headset may cause a hearing loss.

Reference:

Adjust the volume when the sound from the intercom receiver is hard to hear or too loud. Refer to "5. CAMERA SETTINGS and ADJUSTMENT [Adjusting Headset Volume]" (P71) for how to control the intercom volume.

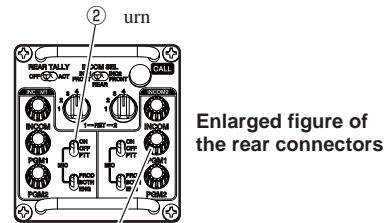
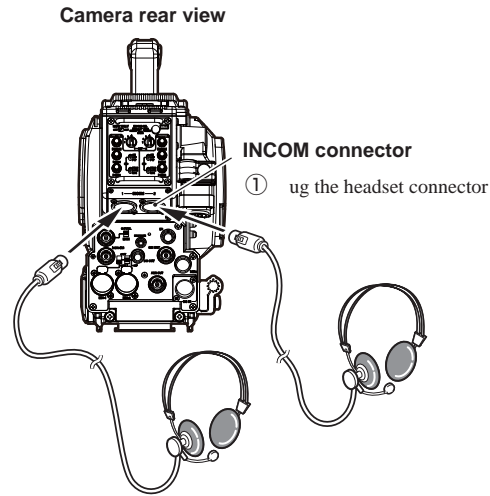

CAUTION: Ensure that the volume is initially set at a minimum level.

Attaching the Shoulder Belt

Attaching the Shoulder Belt

This camera is equipped with the hooks to attach the shoulder belt. Attach or remove the shoulder belt depending on how you use the camera.

- 1 Open the attachment by pressing the upper part of each shoulder belt tab.
- 2 With the attachment open, align the hole in the attachment with the hook on the camera and lift the shoulder belt upward.

Make sure that the shoulder belt attachments are securely attached to the hooks.

CAUTION:

If the shoulder belt attachments are not securely attached to the hooks on the camera, the camera may fall while you are carrying or operating it, resulting in a damage to the camera or injury to the user.

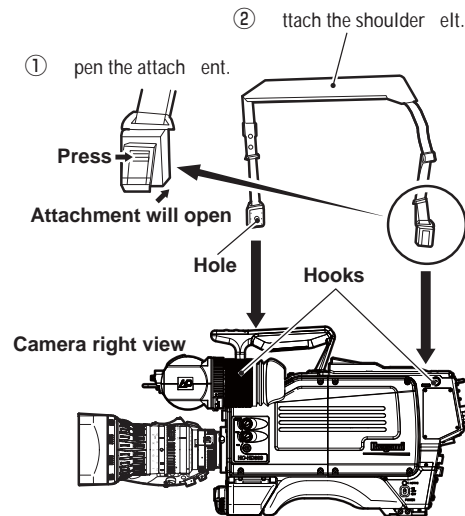

3.3 Power Connection

There are two ways to supply power to the camera. Select the power supply according to the system configuration and operating system.

● To supply from an AC Adapter (External power)

Directly connect the camera and the AC Adapter via a DC POWER cable. Use the AC Adapter specified as DC11V to 16V (4A or more).

● To supply from the BS

Connect the camera and the BS via the fiber cable. The fiber cable contains a power conductor.

Note:

Make sure that the camera POWER switch is OFF before connecting the power. Refer to "Make Sure the Power Switch is OFF" (P33) for how to check the power.

Power Supply from AC Adapter

This section explains how to supply the power from an AC Adapter (external power). For the details on the AC Adapter, refer to the instruction manual accompanying the AC Adapter to be used. This section describes the AC Adapter which has the form as shown below.

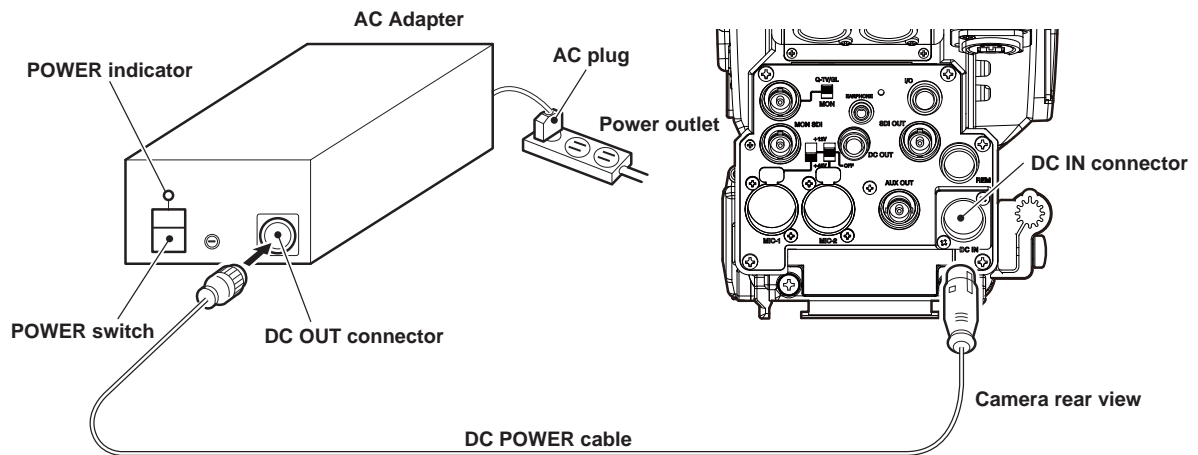

- 1** Make sure the POWER switch on the AC Adapter is OFF.
- 2** Insert the AC plug of the AC Adapter into the power outlet.
- 3** Connect the DC OUT connector on the AC Adapter and the DC IN connector on the camera via the DC POWER cable.
- 4** Turn the POWER switch on the AC Adapter ON.
The POWER indicator on the AC Adapter will light.

Power Supply from BS

Explains how to supply power from the BSF-300.

BSF-300 rear view

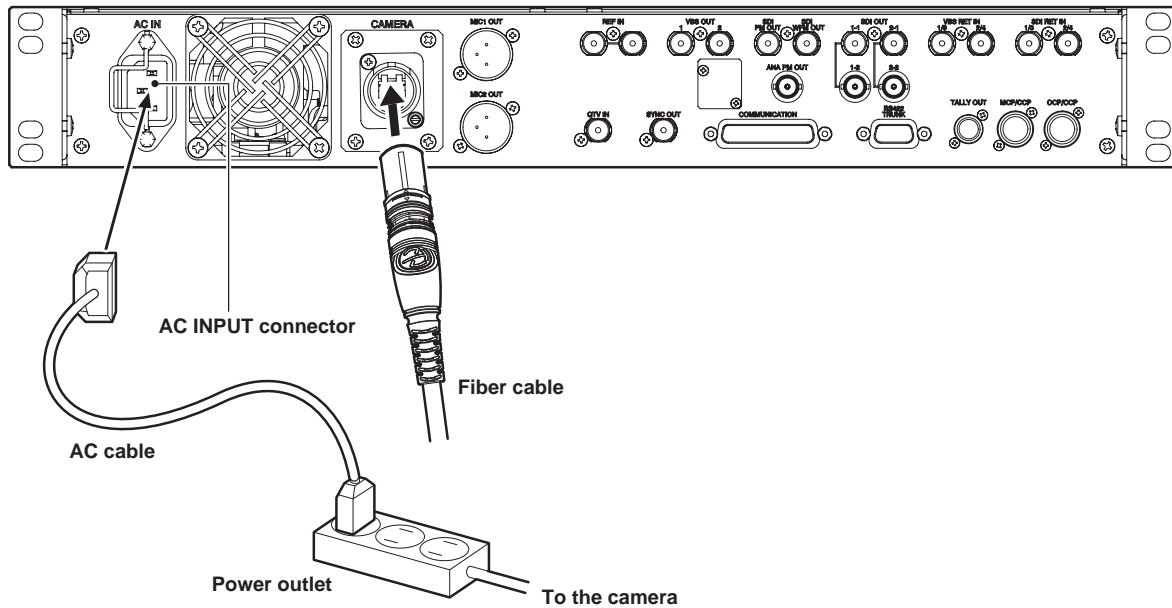

- 1** Make sure the BSF-300 MAIN POWER switch is OFF.
- 2** Connect the AC cable to the AC INPUT connector on the rear of BSF-300.
- 3** Insert the AC plug into the power outlet.
- 4** Connect the BSF-300 and the camera via a fiber cable.

This completes the procedure for connecting power from the BSF-300 to the camera.
There are two methods of switching power to the camera On/Off in this configuration:

- Operating the camera power from the BS.
- Operating the camera power from the OCP (remote control).

■ To Control Power ON/OFF from BS

You can control the power ON/OFF of the camera from the BS.

5 Set the BS MAIN POWER switch on the front of the BS to "ON".

This turns on the power of the BS and lights the BS MAIN POWER indicator. In addition, the status of the camera cable connection between the camera and the BS is automatically checked. When the connection status is determined as normal, power is supplied to the camera, and the HEAD POWER indicator also lights.

BSF-300 front view

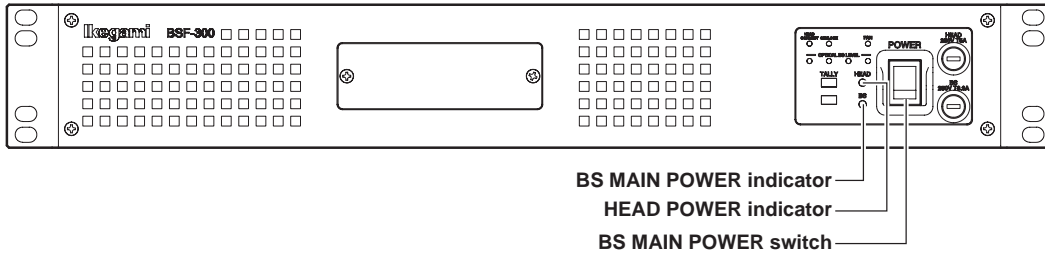

3.4 Monitor Connection

This section explains how to connect the HC-HD300 to the monitor.

Connecting Camera and Monitor

There are three connectors on the rear of the camera to output various video signals. The type of video signal output from each connector is different. Be sure to connect to a correct connector via a coaxial cable in accordance with the monitor to be used.

- Q-TV/GL, MON OUT connector : Selection between Q-TV/GL and MON OUT is made by the Q-TV/GL, MON OUT SELECT switch.
If Q-TV/GL is selected, this connector outputs the Q-TV OUT/VBS signal when the camera is connected to the BS, or it inputs an external synchronization signal (GENLOCK) when the camera is used stand-alone.
When MON is selected, this becomes the monitor output of the camera images, and the same image signals are output as the viewfinder.
- SDI OUT connector : Outputs the digital serial video signal. Applicable to the HD-SDI signal (not applicable to the SD-SDI signal).
- MON SDI connector : Outputs the digital serial video signal. Applicable to the HD-SDI signal (not applicable to the SD-SDI signal).

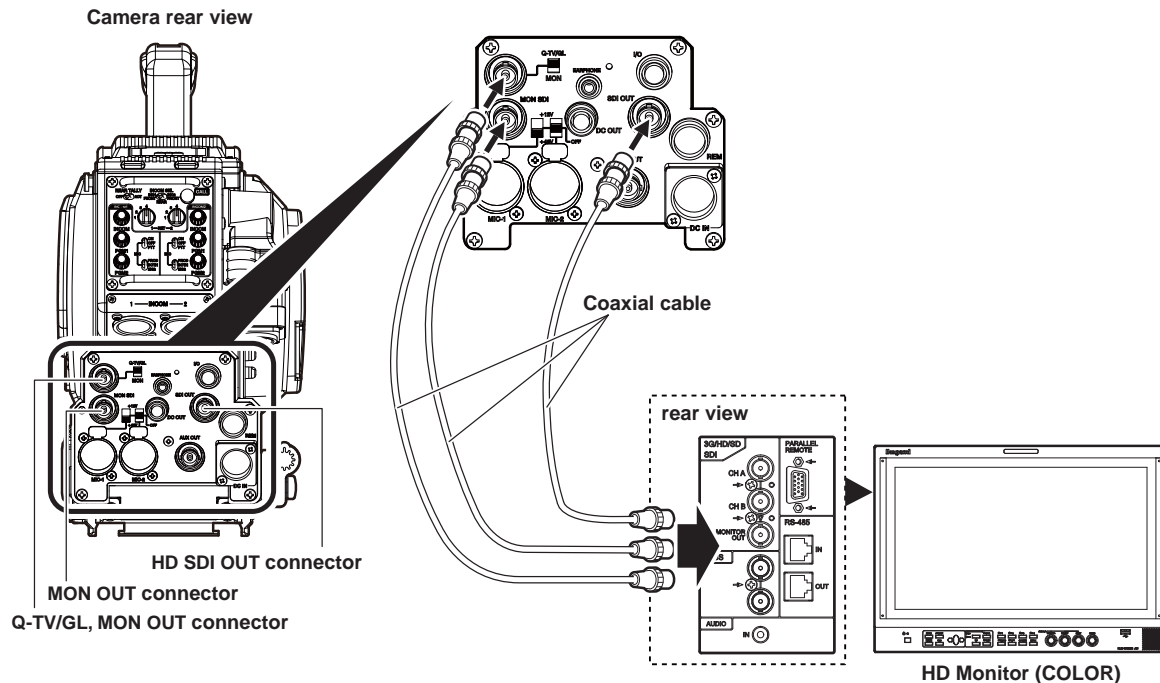

3.5 BS Connection

This section explains how to connect the HC-HD300 to the BS. BSF-300 is used here as an example.

- Fiber cable (2-core single mode): Diameter 9.2mm, Maximum length 350m (when VFL200HD is used)

Connecting Camera and BS

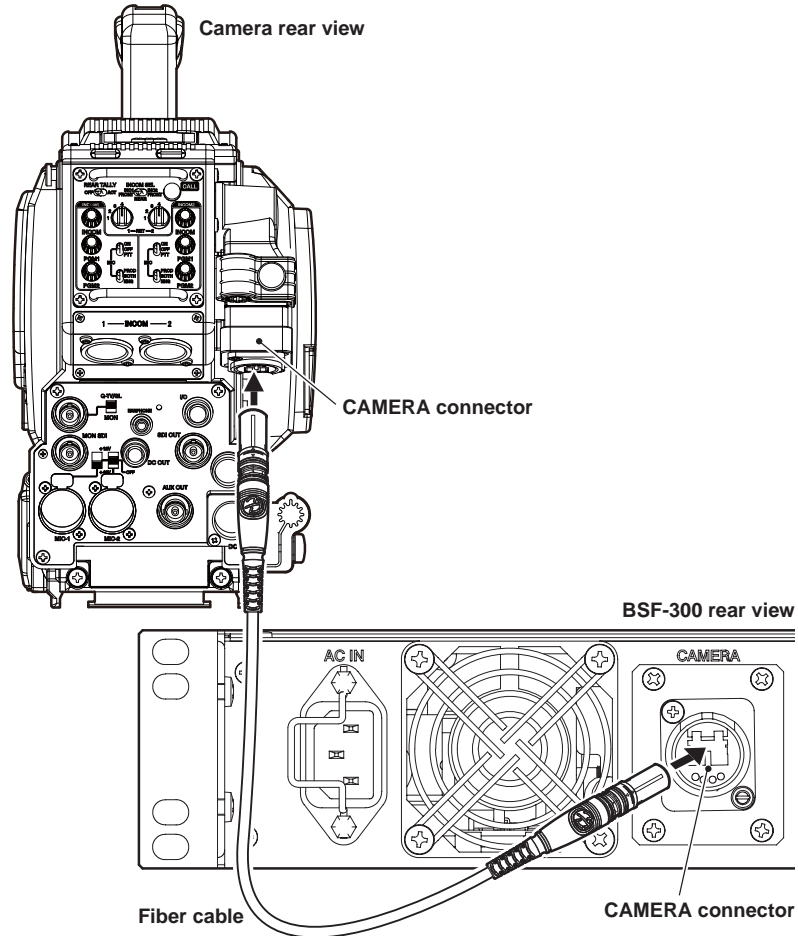

- 1 Connect the CAMERA connector on the rear of the BSF-300 to the CAMERA connector on the rear of the camera via a fiber cable.

CAUTION:

Secure the fiber cable with the CAMERA CABLE clamp on the left side of the camera to remove any slack. Refer to "SAFETY PRECAUTIONS" (iv) described at the beginning of this manual for how to secure the cable with the cable clamp and how to handle the fiber cable.

■ Removing the Fiber Cable

This section explains how to remove the fiber cable.

CAUTION:

When you remove the cable, be sure to hold the plug and pull. Failure to do so may damage the fiber in the cable.

● Camera

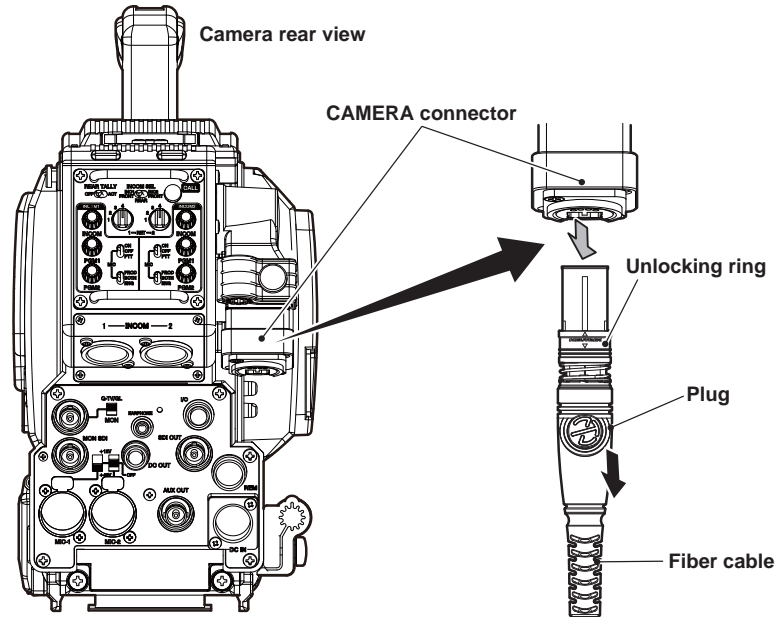

● BS

BSF-300 rear view

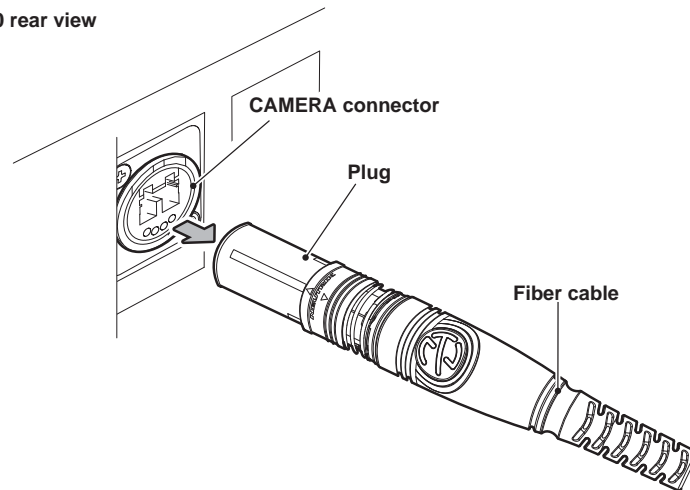

- 1 Remove the cable while pulling the unlocking ring on the fiber cable plug toward you.

If the connector tip is locked, the fiber cable will not be removed. If it is locked, push the fiber cable toward the CAMERA connector, and then remove as described above.

OPERATION



4.1 Operating Procedures

This chapter explains how to operate this product..

Initial Operation Check

When you use the camera for the first time after purchase, ensure that it works properly.

- ◆ 4.2 Switch Position Check (P58)
- ◆ 4.3 Turning ON Power (P60)
- ◆ 4.5 Output Signal Check (P63)
 - Color-Bar Signal Check
 - Test Pulse Check (CAL Signal)
 - Check by Use of External Chart

Preparation Before Shooting

- ◆ 4.4 Viewfinder Adjustment (P62)
 - Diopter Adjustment and Screen Adjustment
 - Display Mode Check
- ◆ 4.5 Output Signal Check (P63)
 - Color-Bar Signal Check
 - Test Pulse Check (CAL Signal)
 - Check by Use of External Chart
- ◆ 4.6 Auto Setup (P65)
 - Auto Black Balance (ABB)
 - Auto White Balance (AWB)

Shooting Settings and Adjustment

Make IRIS and pedestal adjustments and various function settings according to the environment in which the camera is used.

- ◆ Camera menu settings
Refer to "5. CAMERA SETTINGS and ADJUSTMENT" (P69)
- ◆ BS menu settings
Refer to the operation manual accompanying th BSF-300 or other base station to be used.

4.2 Switch Position Check

When the camera is used for the first time, set the switches on the camera to the positions indicated in the figure below, and ensure that the camera works properly. After ensuring that it works properly, set the switches according to the environment in which the camera is used and shooting conditions.

■ Camera Right

- GAIN SELECT switch : 0
- AWB SELECT switch : A
- CC FILTER switch (ECC) : A (3200K)
- ND FILTER switch : 1 (100%)
- OUTPUT SELECT switch : CAM
- SHUTT/SUP-V switch : OFF

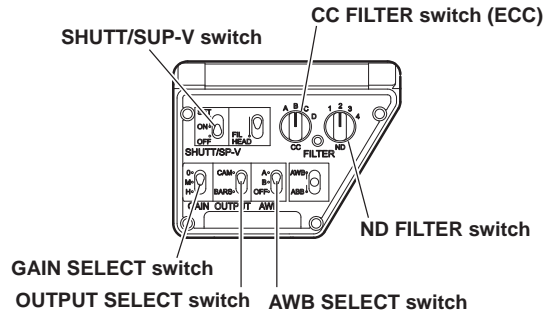

Note:

When the camera is connected to the BS, the switches on the camera are disabled except the CC FILTER switch (ECC) and ND FILTER switch. When the camera has operational priority for the CC FILTER (ECC) and ND FILTER switches, the FILTER local indicator lights. Pressing the FILTER HEAD switch will switch the operational priority between the camera and the BS.

■ Camera Front

- P.FUNC switch : OFF

Note:

When the camera is connected to the BS, you cannot use the P.FUNC switch.

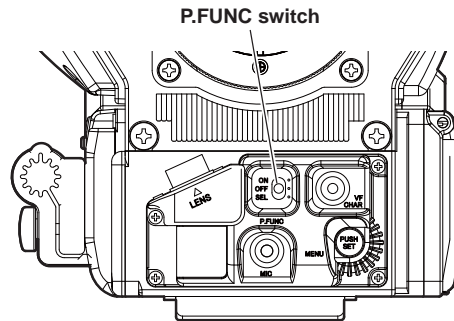

■ Camera Rear

- INCOM FRONT VR SELECT switch : OFF
- ENG MIC switch : ON
- PROD MIC switch : ON
- MIC-1 POWER switch, MIC-2 POWER switch

Depending on the type of microphone to use, the power supply settings differ.

Switch Position	Description
AB+12V	Supplies +12V AB power to the microphone.
OFF	Supplies no power to the microphone. Applicable for a dynamic microphone or a microphone with built-in battery which requires no power supply.
+48V	Supplies +48V Phantom power

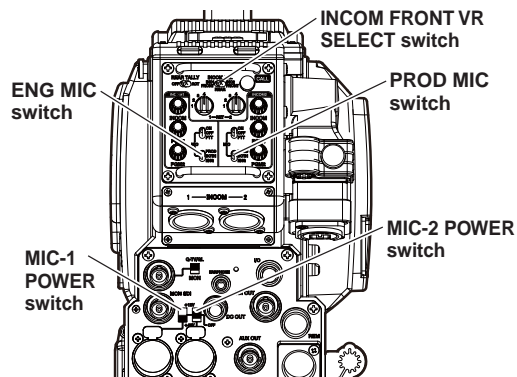

Reference:

For details on the microphone, refer to the instructions accompanying the microphone to be used.

■ Viewfinder

- Assignable SW1 : OFF (Default function is “ZEBRA”).
- Assignable SW2 : OFF (Default function is “TALLY”).
- Assignable SW3 : OFF (Default function is “MONO”).

Note:

You can change Function SW assignment with the MENU of the VF.

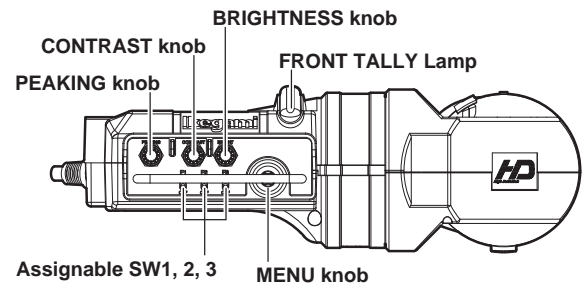

4.3 Turning ON Power

The procedure for turning the power ON/OFF depends on how power is supplied to the camera. This section explains how to supply power from an AC Adapter (External power) and the BS.

Power Supply from AC Adapter

Before turning the camera ON, make sure that the POWER switch on the AC Adapter is ON and the POWER indicator lights.

Reference:

Refer to "3. INSTALLATION and CONNECTION [Power Supply from AC Adapter]" (P49) for how to connect the camera to the AC pack and how to turn the power ON.

1 Set the POWER switch on the camera to EXT.

Power will be supplied to the camera, and the POWER indicator will light in green.

Power Supply from BS

Before turning the camera ON, set the switches to the following positions in normal operations. The power is turned ON/OFF by the MAIN POWER switch on the BS.

	Switch	Switch Position
Camera	POWER switch	BS
BS	BS MAIN POWER switch	OFF
	HEAD POWER switch	I
OCP(*)	CAM POWER switch	ON

(*) When OCP-10 is used, the setting for the CAM POWER switch is not necessary.

1 Turn ON the MAIN POWER switch on the BS.

The BS checks the fiber cable connection and supplies power to the camera if the cable is properly connected. The CABLE indicator on the BS will indicate the connection status of the fiber cable.

NORMAL (green) : Lights when the fiber cable is normally connected.

2 Make sure that the ALARM indicator on the OCP or MCP is not flashing

When the camera self-diagnosis function detects errors, the ALARM indicator flashes, and the self-diagnosis information will be displayed for 20 seconds.

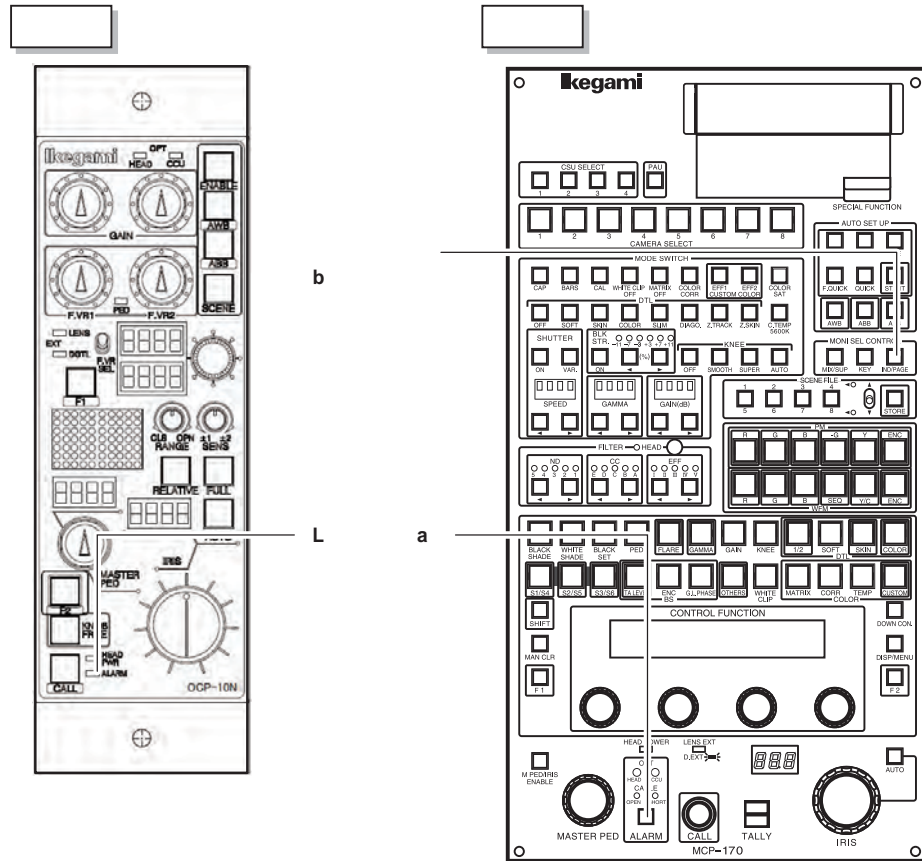

4

OPERATION

Note:

You can display the self-diagnosis information and check the status on the PM attached to the base station by pressing the PM IND/PAGE button even when the ALARM indicator is not flashing. If an OCP-10 is used, make sure you assign a function to an F switch for this function..

■ To Control Power ON/OFF from OCP

It is possible to use the OCP to control the camera power switching.

When the CAM POWER switch of OCP has been turned ON/OFF, only the camera power is turned ON/OFF. The BS power is not turned ON/OFF.

4.4 Viewfinder Adjustment

When you want to obtain a sharp image or enhance the edge of the image in the viewfinder, adjust the viewfinder to suit the environment in which the camera is used.

Reference:

Refer to "3. INSTALLATION and CONNECTION [Mounting and Removing the Viewfinder]" (P45) for how to adjust the position and angle of the viewfinder.

Diopter Adjustment and Screen Adjustment

■ Diopter Adjustment

Adjust the focus of the image in the viewfinder to suit the eyesight of a camera operator.

- 1 While pressing the Diopter Adjustment lever, slide in the direction of the arrow.

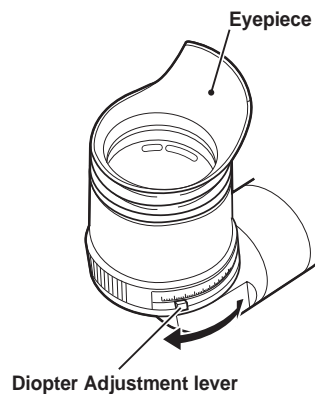

■ Screen Adjustment

Adjust when the viewfinder image is not clearly viewable or if you want to enhance the edge of the image.

- 1 Adjust the knobs on the viewfinder.
 - PEAKING knob : Adjust the sharpness of the edge of the image.
 - CONTRAST knob : Adjusts the contrast of the image.
 - BRIGHTNESS knob : Adjusts the brightness of the image.
 - MENU knob : Used to navigate the menu.

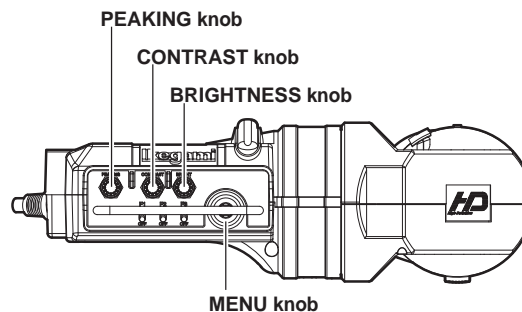

Display Mode Check

You can select the display mode for various markers and characters displayed in the viewfinder. Set the display mode suitable for the conditions in which the camera is used.

Reference:

The display mode is set by the menu. Refer to "5. CAMERA SETTINGS and ADJUSTMENT [Menu Configuration and content]" (P81).

4.5 Output Signal Check

After turning ON the power, ensure that signals are correctly output on the PM and WFM. If the signals are not output for some reason, check the following before concluding that there is a failure.

- Are the cables properly connected?
- Are the switches correctly set?
- Is the breaker thrown?
- Is the POWER switch set to ON?

Reference:

Refer to "3. INSTALLATION and CONNECTION" (P31) for connection of peripheral equipment.

Color-Bar Signal Check

- 1 Set the BARS button on the OCP or MCP to ON.

Ensure that a normal color-bar signal is output.

To output color-bar signals to the monitor system, operate the MONITOR SELECT button.

Note:

If an OCP-10 is used, make sure you assign the BARS function to an F switch for this check.

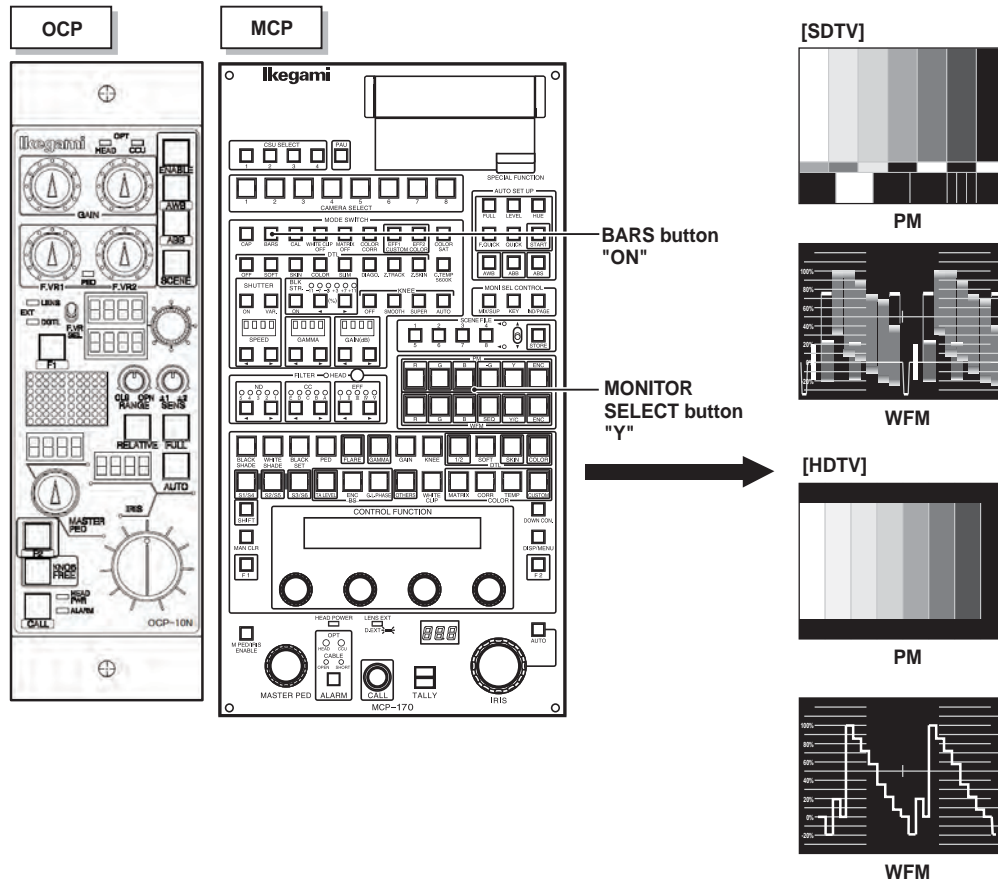

Note:

When no color is displayed on the SDTV signal while you use MCP-170 and press the "Y" button of the MONITOR SELECT buttons, refer to the operation manual for MCP-170.

Test Pulse (CAL Signal) Check

Check if the level of the video system is normal.

- 1 Set the CAL button on the OCP or MCP to ON.

Ensure that 100% level of test pulse is output.

Note:

If an OCP-10 is used, make sure you assign the CAL function to an F switch for this check.

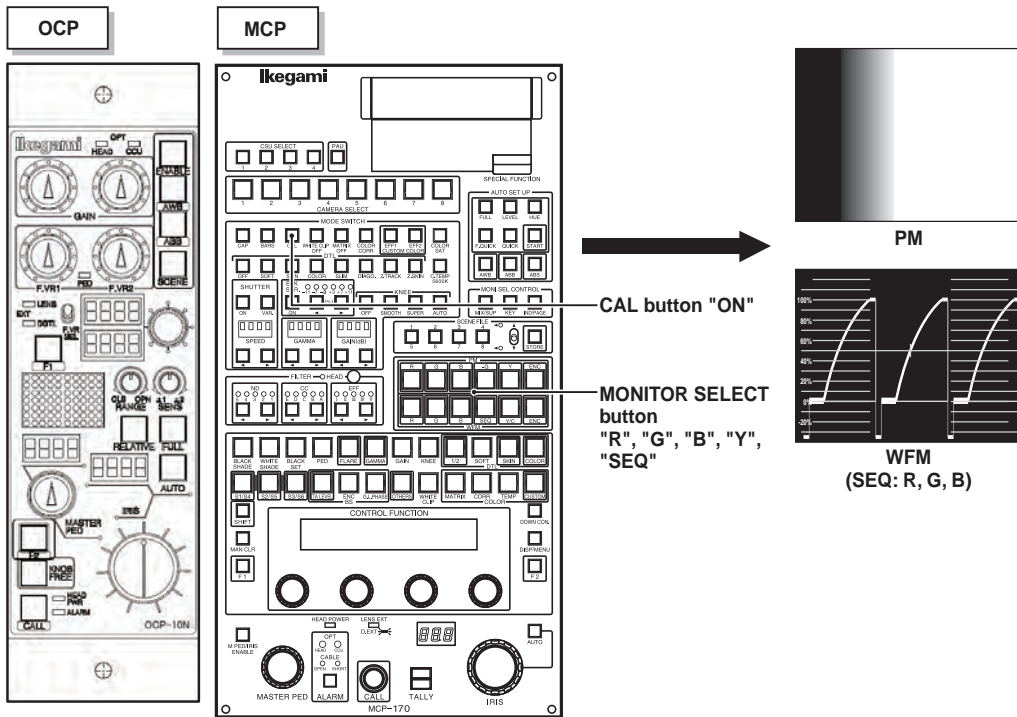

External Chart Check

Shoot an external chart and ensure that the image is normal.

4.6 Auto Setup

The camera is equipped with an auto setup function that automatically adjusts various levels and settings in the CPU of the camera.

● Auto White Balance (AWB)

Sets the white level of the R and B signals. White balance needs to be readjusted when the color temperature of the light source changes or optical filters are changed because white balance is affected by the color temperature of the light source and by optical filters.

● Auto Black Balance (ABB)

Sets the black level of the R, G and B signals. Though black balance is affected neither by the color temperature of the light source nor by optical filters, it needs to be readjusted when GAIN is changed or the ambient temperature has changed significantly.

Note:

Auto setup converges on the reference file value. This reference file value is created in the memory at shipment. The reference file needs to be created again if you want to change the value.

Auto setup can be activated from the camera, OCP, and MCP. See the table in the next page for which device can activate which auto setup function.

Reference:

For how to execute auto setup from the OCP/MCP, refer to the relevant operation manual.

■ Auto Setup Function List

Control Item	Auto Setup Function					
	OCP		MCP		Camera	
	AWB	ABB	AWB	ABB	AWB	ABB
LEVEL						
BLK SET		R, G, B		R, G, B		R, G, B
PED		R, G, B		R, G, B		R, G, B
GAIN	R, B		R, B		R, B	

■ Auto Setup Screen

When various auto setup functions execute, the execution status is displayed in the viewfinder or on the PM. The currently executing item is indicated by the cursor.

When auto setup successfully completes, "OK" appears beside "Judgement". When it fails, "NG" appears beside "Judgement" with the cursor on the failed item.

[Auto Setup Monitor Execution Display Screen]

*** AUTO SETUP MONITOR ***		[HC-HD300]	
Function: AUTO BLACK SHADING			Executing auto setup type
Mode: Lens No.1	Chart: EXT.		
Judgement: Setting	Position: H V		Setup result
Gain	R G B	W-Shading Saw	R G B
Gamma	R G B	W-Shading Para	R G B
Flare	R G B		
Pedestal	R G B		
Black Set	R G B		
Iris	CNTRL		
White Clip	R G B	Chart	SEARCH
Knee Slope	R G B		
Knee Point	R G B		
Auto Knee Slope	R G B		
Auto Knee Point	R G B		
Skin Hue	R G B		

Auto White Balance

Auto white balance can be activated from the camera, OCP, or MCP. This section explains how to activate from the camera.

- 1 Use the AWB SELECT switch to select the memory (Ach or Bch) in which to store the execution result.

AWB settings can be stored in two memories. Use them selectively depending on different conditions.

A : Ach memory

B : Bch memory

OFF: White balance adjustment is in the preset condition (3200K). AWB cannot be activated when the switch is set to this position.

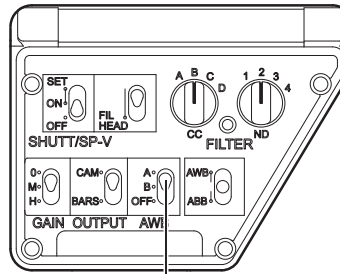

① Set the B switch to select the memory.

Note:

The data previously stored in the memory is overwritten. Also, when the camera is connected to the BS or remote controller, the AWB SELECT switch is disabled.

- 2 Use the CC FILTER switch (ECC) and ND FILTER switch on the right side of the camera to set the optical filter which suits the light source.

If the operational priority for the filter is not given to the camera, press the FILTER HEAD switch to switch the operational priority to the camera. When the priority is given to the camera, an asterisk (*) is displayed in the viewfinder.

- 3 Shoot a subject which contains something white.

Make sure that the white subject fills at least 10% of the screen, and make sure it is the brightest subject in the picture.

- 4 Set the AWB/ABB switch to AWB.

Auto white balance is now activated.

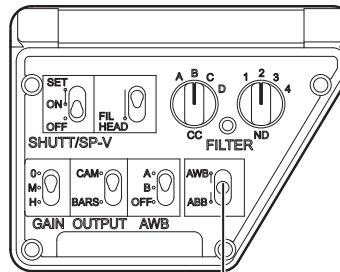

④ Set the AWB/ABB switch to AWB.

- 5 Check the result.

Upon completion of auto white balance, "OK" or "NG" appears on the viewfinder screen. If "NG" appears, check if the subject meets the conditions described above and the optical filter setting is appropriate, and retry from Step 3.

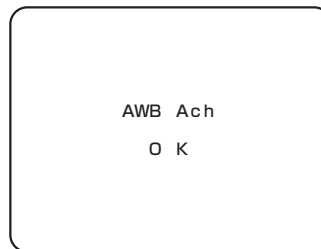

CAUTION:

Be sure to set the R, B GAIN control knob on the OCP or MCP to the center position before activating the auto white balance from the camera. If the control knob is not at the center position, the control range may be biased.

Note:

To activate the auto white balance from an OCP, press the AWB button on the panel.

To activate it from an MCP, press the AWB button on the LCD or on the panel, depending on the MCP model.

Auto Black Balance

Auto black balance can be activated from the camera, OCP, or MCP. This section explains how to activate from the camera.

1 Set the AWB/ABB switch to ABB.

The lens iris is automatically closed, and auto black balance is now activated.

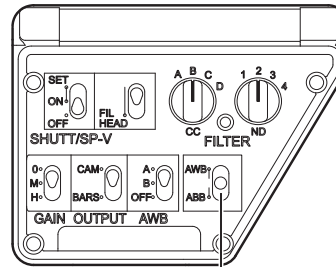

① Set the AWB/ABB switch to ABB.

2 Check the result.

Upon completion of auto black balance, "OK" or "NG" appears on the viewfinder screen.

CAUTION:

Be sure to set the R/G/B BLACK and MASTER PEDESTAL control knobs on the OCP to the center position before activating the auto black balance from the camera. If the control knobs are not at the center position, the control range may be biased.

Note:

To activate the auto black balance from an OCP, press the ABB button on the panel.

To activate it from an MCP, press the ABB button on the LCD or on the panel, depending on the MCP model.

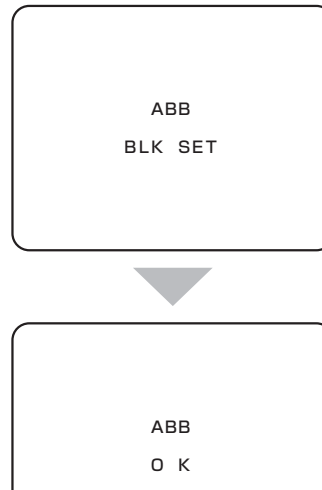

4.7 Preparation for Shooting in Particular Environment

When the camera is used in a particular environment such as where the temperature is extremely low, where the camera is subject to direct sunlight throughout the day, or where the electromagnetic field is so strong that the electronic circuits malfunction, it is necessary to take the following protective measures for proper operation of the camera.

■ **Shooting in an extremely cold location**

Change the oil with that for cold districts in advance. Otherwise the oil freezes because of the extremely low temperature and the movement of the tripod, focus, zoom, and iris will become heavy. Put a cold-weather cover on the camera, and fully warm up the camera before using it.

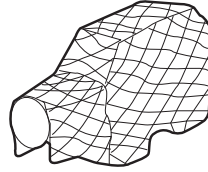

Cold-weather cover

■ **Shooting in a dusty place or in the rain**

The camera is dustproof and rainproof design. However, when shooting in a dusty place or in the rain, put a dustproof cover or a rainproof cover on the camera

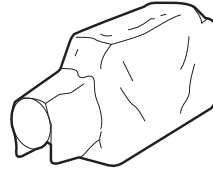

Dustproof cover

■ **Shooting where the electromagnetic field is strong**

When shooting where the electromagnetic field is excessively strong, such as in airports, military bases or transmitting stations, completely shield the camera by thoroughly covering it with aluminum foil.

It is necessary to take the same measure for other devices.

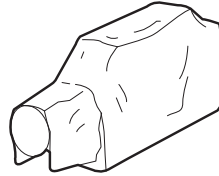

Rainproof cover

CAMERA SETTINGS and ADJUSTMENT



5.1 Settings Using Switches on the Camera

Adjusting Headset Volume

This chapter explains how to control the headset volume.

CAUTION:

Do not set the INCOM-1 control knob, INCOM-2 control knob, INCOM-1 PGM-1/2 control knob, and INCOM-2 PGM-1/2 control knob to near maximum level from the beginning. Setting the volume level too high with the intercom headset on your ears may damage your eardrums. If you suddenly set the volume level too high, it may also damage the headset. Excessive sound pressure from the headset may cause a hearing loss.

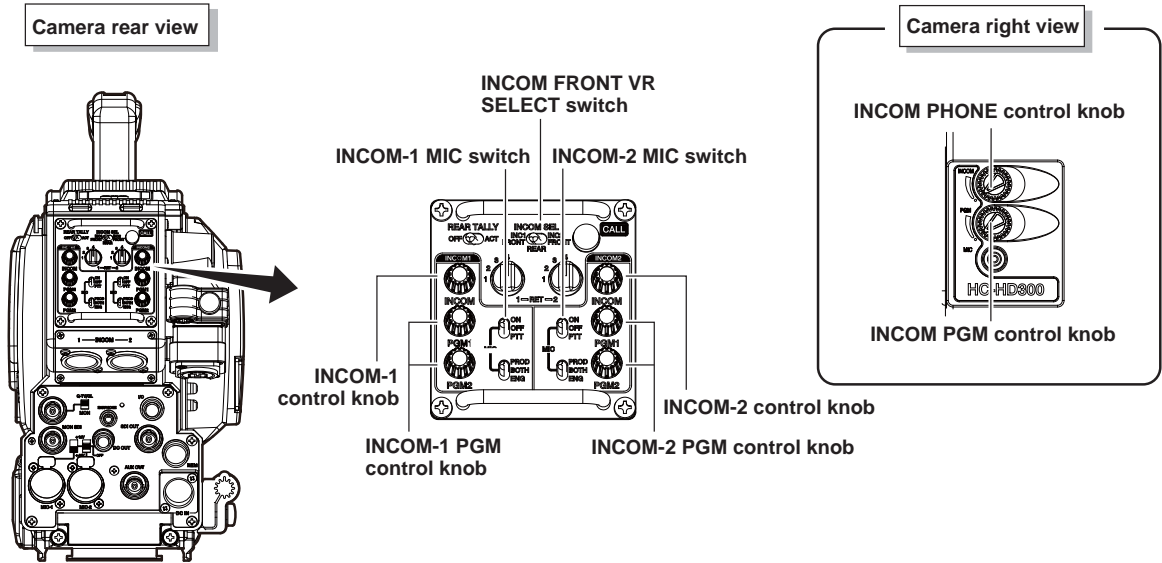

Adjusting Intercom Volume

The intercom volume can be controlled on the rear or right side of the camera. Perform Step 1 to control the volume on the rear of the camera, and Step 2 and 3 to control on the right side of the camera.

- 1** Turn the INCOM-1 control knob and INCOM-2 control knob on the rear of the camera to adjust the volume.
- 2** Set the INCOM FRONT VR SELECT switch on the rear of the camera to INCOM-1 or INCOM-2.
- 3** Turn the INCOM PHONE control knob on the right side of the camera to adjust the volume.

CAUTION:

Be sure to adjust the volume to the appropriate level while listening to sound through the headset.

■ Adjusting Intercom PGM Volume

The intercom PGM volume can be controlled on the rear or right side of the camera. Perform Steps 1 and 2 to control the volume on the rear of the camera, and Steps 1, 3, and 4 to control on the right side of the camera.

- 1** Use the INCOM-1 PGM-1/2 switch or INCOM-2 PGM-1/2 switch on the rear of the camera to select an intercom PGM line.
- 2** Turn the INCOM-1 PGM-1/2 control knob and INCOM-2 PGM-1/2 control knob on the rear of the camera to adjust the volume.
- 3** Set the INCOM FRONT VR SELECT switch on the rear of the camera to INCOM-1/2.
- 4** Turn the INCOM PGM control knob on the right side of the camera to adjust the volume.

CAUTION:

Be sure to adjust the volume to the appropriate level while listening to sound through the headset.

Selecting Shutter Speed

There are two types of shutter: preset shutter with 6 different levels of shutter speed set in advance, and variable shutter which the user can set the shutter speed to any speed.

- Preset shutter : Select from 6 levels of shutter speed: 1/100, 1/120, 1/250, 1/500, 1/1000 and 1/2000.
- Variable shutter : Set the suitable shutter speed within the following range.
 - 1/60.2 to 1/2040 seconds (scanning mode: 59.94Hz)
 - 1/50.2 to 1/2000 seconds (scanning mode: 50Hz)

Variable Shutter function is effective when shooting a computer screen that is not synchronized with the normal TV frame rate, or a subject in quick motion such as the club swing of a golfer in order to playback in slow motion. With a faster shutter speed, a high-resolution picture can be shot without blur caused by the camera shaking when shooting subjects with vigorous movement, for example a live coverage of a sporting event.

CAUTION:

Setting from the camera is effective only for the self-contained system operation. When the camera is connected to the BS, set it from the control panels on the BS.

Note:

- The sensitivity decreases as the shutter speed increases. Ensure that the lighting condition is sufficient for faster shutter speed settings.
- When a remote controller is connected, the operation of the remote controller has priority over the operation switches on the camera (when SEMI REMOTE MODE is set to "OFF"). For details on how to operate the various remote controllers, refer to the instruction manuals attached to the remote controllers.

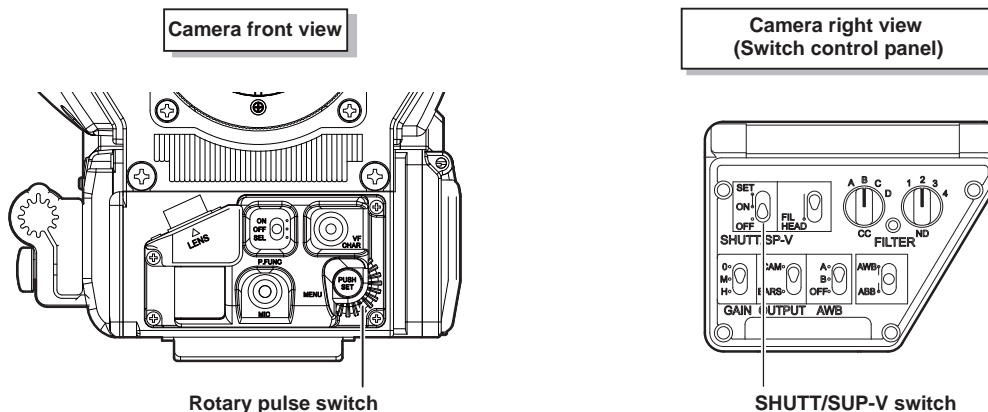

- 1 Select "1" or "2" from MENU (1/4) "VF DISPLAY" - "DISPLAY MODE."

Characters appear in the viewfinder.

Reference:

Refer to "5.2 Settings from the Menu [Menu Configuration and content]" (P81) for how to display characters in the viewfinder.

- 2 Set the SHUTT/SUP-V switch on the right side of the camera to SET.

One of the following modes is displayed:

- Preset shutter speed
- Variable shutter speed
- SUPER-V

Note:

Each time the SHUTT/SUP-V switch is pressed to the SET position, the mode switches are in the order of preset shutter, variable shutter and SUPER-V.

- 3 Select "PRESET SHUTTER SPEED" or "VARIABLE SHUTTER SPEED."

- 4 While the characters are flashing in the viewfinder, turn the rotary pulse switch to the appropriate shutter speed and press the SET button.

The value will be confirmed.

Note:

- The flashing stops automatically in approximately 3 seconds after the setting operation ends.
- When the characters are not flashing in the viewfinder, press the SET button. The characters will start flashing and the shutter speed setting will be enabled.
- There are three ways to confirm the shutter speed:
 - Press the SET button.
 - Wait until the flashing stops.
 - Set the SHUTT/SUP-V switch to OFF. The displayed speed is maintained until the switch is set to ON. The shutter speed is validated when the switch is set to ON.

■ To cancel the Shutter Speed

- 1 Set the SHUTT/SUP-V switch to OFF.

Enhancing the Vertical Resolution (Super-V Function)

Super-V function enhances the vertical resolution. It is activated from the camera, MCP, or OCP.

Note:

- The sensitivity of the camera decreases when in the Super-V function mode.
- When a remote controller is connected, the operation of the remote controller has priority over the operation switches on the camera.

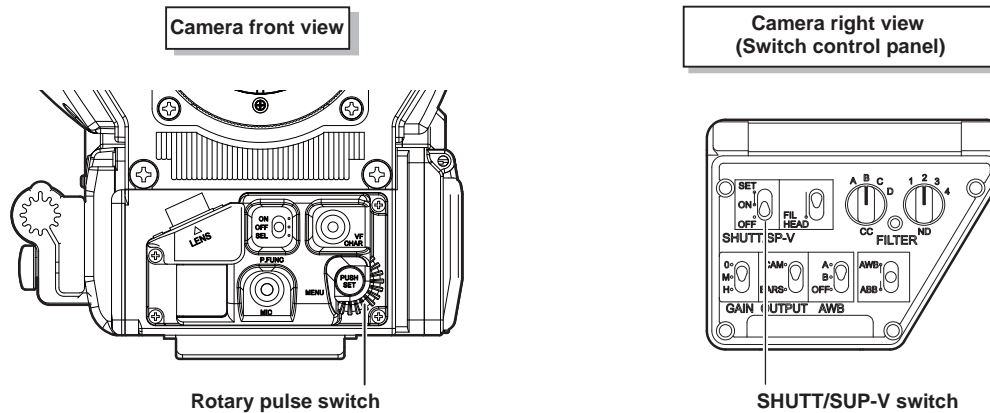

- 1 Select "1" or "2" from MENU (1/4) "VF DISPLAY" - "DISPLAY MODE."
Characters appear in the viewfinder.

Reference:

Refer to "5.2 Settings from the Menu [Menu Configuration and content]" (P81) for details.

- 2 Set the SHUTT/SUP-V switch on the right side of the camera to SET.
One of the following modes is displayed:
 - Preset shutter speed
 - Variable shutter speed
 - SUPER-V

Note:

Each time the SHUTT/SUP-V switch is pressed to the SET position, the mode switches are in the order of preset shutter, variable shutter and SUPER-V.

- 3 Select "SUPER-V."

Note:

The flashing stops automatically in approximately 3 seconds after the setting operation ends.

- 4 Press the SET button.

■ To Cancel the Super-V Function

- 1 Set the SHUTT/SUP-V switch to OFF.

Switching the GAIN

When using the camera under the conditions such as evening, night time, or indoor use, the gain (sensitivity) of the camera needs to be adjusted to suit the brightness of the subject. The gain can be adjusted on the camera or from the remote controller.

■ Adjusting the Gain on the Camera

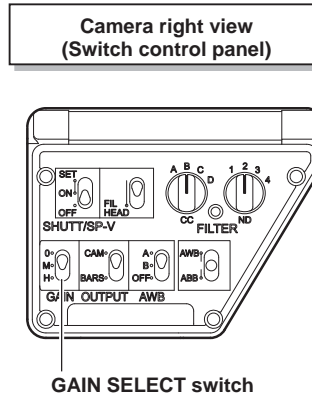

- 1** Use the GAIN SELECT switch on the right side of the camera to switch the setting according to the shooting conditions.

Note:

Allocate gain values to the GAIN SELECT switch in advance. Refer to "5.2 Settings from the Menu [Menu Configuration and content]" (P81) for how to allocate gain values.

■ Adjusting the Gain from the Remote Controller

Note:

When a remote controller is connected, the operation of the remote controller has priority over the operation switches on the camera (when SEMI REMOTE MODE is set to "OFF").

Reference:

For details on how to operate the various remote controllers, refer to the instruction manuals attached to the remote controllers.

- 1** Use the GAIN (dB) on the remote controller to switch the setting according to the conditions.

Allocating Functions to the P.FUNC Switch

The user can select a function to allocate to the P.FUNC (Personal Function) switch. By allocating the function used most frequently, the user can easily operate the camera.

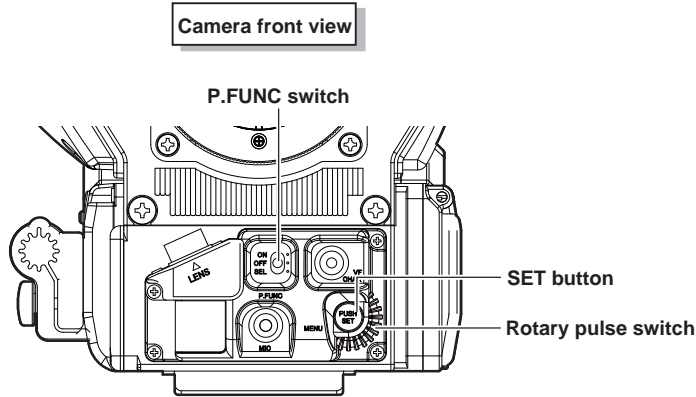

- 1 Set the P.FUNC switch on the front of the camera to SEL.

The selection display flashes.

- 2 Turn the rotary pulse switch to select the function to be allocated, and press the SET button.

The selected function is allocated to the P.FUNC switch.

The following table shows the functions that can be allocated to the P.FUNC switch:

Selection Display	Function
SKIN DTL	Turns ON/OFF the SKIN DTL function
IRIS+CORR	Turns ON/OFF the mode to adjust the iris by approximately +1/2 STOP when AUTO IRIS is set
IRIS++CORR	Turns ON/OFF the mode to adjust the iris by +1 STOP when AUTO IRIS is set
AUTO KNEE	Turns ON/OFF the AUTO KNEE function
SOFT DTL	Turns ON/OFF the SOFT DTL function
SCENE-1	Turns ON/OFF scene file 1
SCENE-2	Turns ON/OFF scene file 2
SCENE-3	Turns ON/OFF scene file 3
SCENE-4	Turns ON/OFF scene file 4
SCENE-5	Turns ON/OFF scene file 5
SCENE-6	Turns ON/OFF scene file 6
SCENE-7	Turns ON/OFF scene file 7
SCENE-8	Turns ON/OFF scene file 8

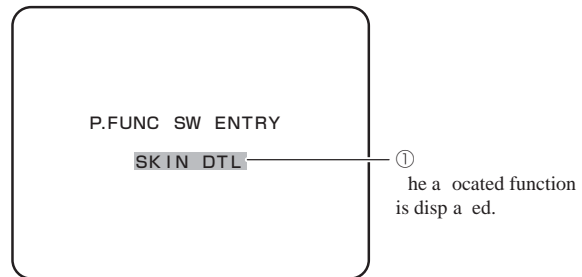
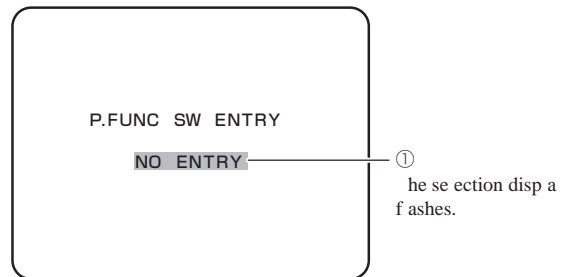

- 3 Set the P.FUNC switch to ON.

The allocated function is now activated.

Note:

Setting the P.FUNC switch to OFF will turn the allocated function OFF.

Screen Detail Enhancement (DTL)

There are two DTL functions available for selection by the P.Function switch: skin DTL and soft DTL.

Term:

Skin DTL

Skin DTL function suppresses the amount of the edge signals in the skin colored area, while maintaining the DTL setting for the entire picture. To achieve the best effect, it is important to ensure that the skin DTL function does not affect the clothing and colors appearing immediately next to the skin colors.

Term:

Soft DTL

In a scene where there is large luminance change, the DTL edge can become high producing an unnatural appearance. The Soft DTL function acts as a limiter on the maximum white and black edge from the detail system, and can be used to prevent harsh edges.

There are two ways to activate the skin DTL and soft DTL functions: allocating the function to the P.FUNC switch or activating from the remote controller.

■ Allocating the Function to the P.FUNC Switch

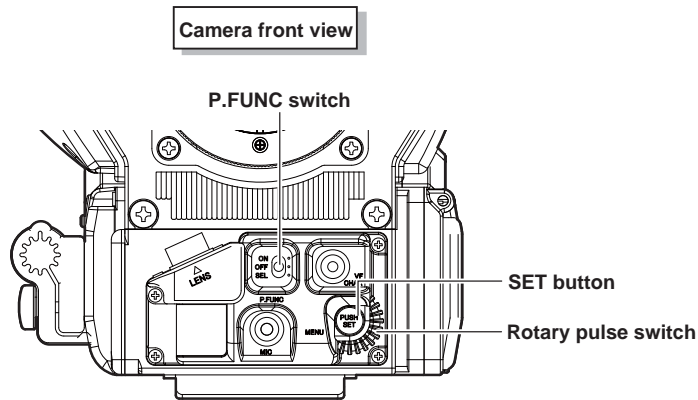

- 1 Set the P.FUNC switch on the front of the camera to ON.

Reference:

Allocate the skin DTL or soft DTL function to the P.FUNC switch in advance. Refer to "5.1 Settings by Switches [Allocating Functions to the P.FUNC Switch]" (P76) for how to allocate the function.

■ Activating from the Remote Controller

Reference:

For details on how to operate the various remote controllers, refer to the instruction manuals attached to the remote controllers.

5.2 Settings from the Menu

Basic Operation of the Menu

The menu function can set up the items to display in the viewfinder and other various status of the camera to suit the shooting conditions. The selection and setting of each item are performed by displaying the main menu/submenu in the viewfinder or the monitor.

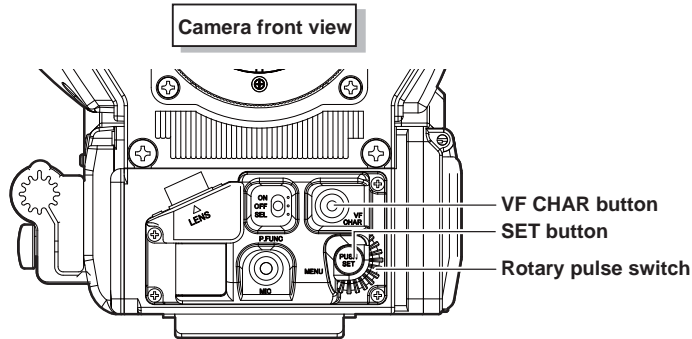

Rotary pulse switch : Used to select a setting item.

SET button : Pressed to confirm the selection and setting.

VF CHAR button : Used with the SET button to switch to the menu mode and display the menu.

■ Displaying the Simple Menu

This section explains how to display the simple menu in the viewfinder and monitor.

- 1 Press the SET button while holding down the VF CHAR button on the front of the camera.
The main menu appears in the viewfinder and monitor.

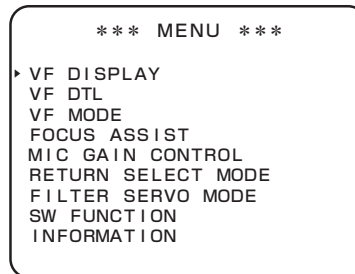

■ Displaying the Main Menu

This section explains how to display the main menu in the viewfinder and monitor.

- 1 Press and hold the SET button while holding down the VF CHARA button on the front of the camera.
The simple menu appears in the viewfinder and monitor first, and then the screen switches to the main menu.

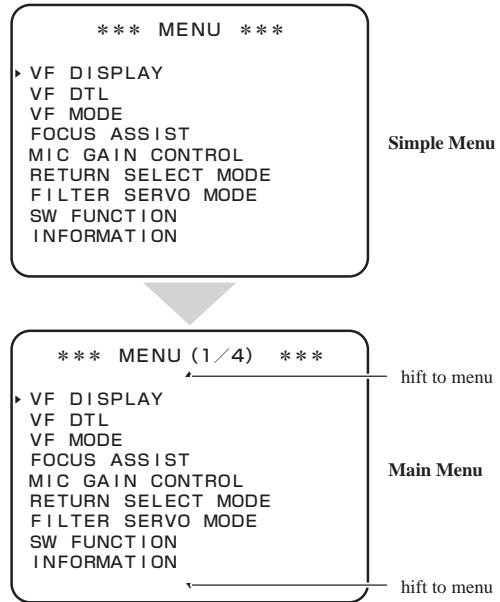

■ Displaying the Submenu

You can perform various settings on the submenu that is displayed from the main menu in the viewfinder or monitor.

- 1 Make sure that the main menu is displayed.

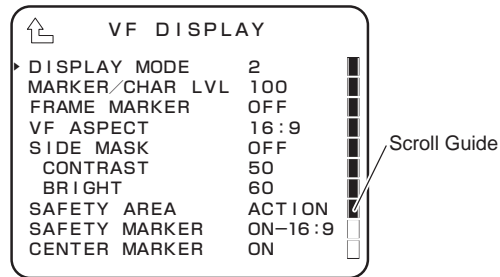

- 2 Turn the rotary pulse switch on the front of the camera to position the cursor on the setting item, and press the SET button.
The submenu appears, on which you can perform various settings.

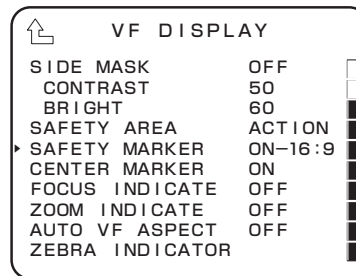

CAUTION:

If the SET button is not pressed after selecting a value in the mode selection column, the change may be canceled.

Note:

- To return to the main menu, select "⏪" and press the SET button.
- The scroll guide is displayed on the submenu containing multiple items.

■ **Exiting the Menu**

This section explains how to exit the main menu/submenu in the viewfinder or monitor.

- 1** Press the VF CHAR button on the front of the camera.

The main menu/submenu disappears.

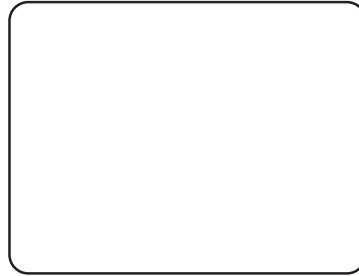

Menu Configuration and content

The following lists the camera menu configuration.

■ MENU (Simple Menu)

The simple menu is the same as MENU (1/4) described below. Refer to items in MENU (1/4) for details of each menu.

■ MENU (1/4)

Menu Item	Initial setting	Setting value	Description, Remarks	MENU DATA	
				ALL	VF
VF DISPLAY					
DISPLAY MODE	2	OFF, 1, 2	1 : Only the markers are constantly displayed. Information related to characters is displayed for 2 seconds during function operation and when changing parameters. 2 : The markers and characters are displayed at all times. OFF : The markers and characters are constantly OFF, and only the warning messages are displayed.	<input type="radio"/>	<input type="radio"/>
MARKER/CHAR LVL	100	0 to 100	Sets the brightness levels of the markers and characters. The brightness level gets dark in the direction of "1".	<input type="radio"/>	<input type="radio"/>
FRAME MARKER	OFF	ON-16:9, ON-14:9, ON-13:9, ON-4:3, OFF	Sets the frame marker.	<input type="radio"/>	<input type="radio"/>
VF ASPECT	16:9	16:9, 4:3	Sets the VF aspect ratio.	<input type="radio"/>	<input type="radio"/>
SIDE MASK	OFF	OFF, ON-4:3, ON-13:9, ON-16:9	Sets the side mask.	<input type="radio"/>	<input type="radio"/>
CONTRAST	50	0 to 100	Adjusts the side mask contrast level.	<input type="radio"/>	<input type="radio"/>
BRIGHT	60	0 to 100	Adjusts the side mask brightness level.	<input type="radio"/>	<input type="radio"/>
SAFETY AREA	ACTION	ACTION, TITLE	ACTION : Area marker of 93% of the screen height and width. TITLE : Area marker of 89% of the screen height and width.	<input type="radio"/>	<input type="radio"/>
SAFETY MARKER	ON-16:9	ON-4:3, ON-16:9, OFF	Sets the safety marker.	<input type="radio"/>	<input type="radio"/>
CENTER MARKER	TYPE1	TYPE1, TYPE2, TYPE3, OFF	Sets the center marker.	<input type="radio"/>	<input type="radio"/>
FOCUS INDICATE	ON	ON, OFF	Only active when using the serial lens.	<input type="radio"/>	<input type="radio"/>
ZOOM INDICATE	ON	ON, OFF	Only active when using the serial lens.	<input type="radio"/>	<input type="radio"/>
AUTO VF ASPECT	OFF	ON, OFF	Switches the VF aspect ratio in linked motion with the output mode of the BS/CCU down converter.	<input type="radio"/>	<input type="radio"/>
ZEBRA INDICATOR			Overlaps the striped pattern signal on the image if the image level has exceeded the individual DETECT LEVELS. The zebra indicator goes ON/OFF with the VF special switch. -Zebra 1 signal : Fine, slanted striped pattern signal flowing toward the upper right of the screen. *Use to control the tone of the entire screen. -Zebra 2 signal : Thick, slanted striped pattern signal flowing to the lower right of the screen. *Used for controlling the tone of the subject, such as face tone, etc		
ZEBRA1 DETECT	100%	30 to 109%	Sets the DETECT LEVEL of the 1st zebra indicator.	<input type="radio"/>	<input type="radio"/>
ZEBRA2 IND	OFF	ON, OFF	Selects whether there is a 2nd zebra indicator or not.	<input type="radio"/>	<input type="radio"/>
ZEBRA2 DETECT	70%	30 to 109%	Sets the DETECT LEVEL of the 2nd zebra indicator.	<input type="radio"/>	<input type="radio"/>
ZEBRA IND LVL	78	1 to 100	Adjusts the overlap level of the zebra indicator.	<input type="radio"/>	<input type="radio"/>
VF DTL					
BOOST FREQ	10MHz	10MHz, 15MHz, 18MHz, 18MHzWIDE	Selects the frequency to be boosted.	<input type="radio"/>	<input type="radio"/>
NOISE SUP	5	0 to 10	Sets the removal level of the noise signal.	<input type="radio"/>	<input type="radio"/>
VF DTL	35	0 to 100	Sets the VF detail amount. The detail amount decreases in the direction of "0" and increases in the direction of "100".	<input type="radio"/>	<input type="radio"/>
V FILTER	OFF	ON, OFF	Turns on/off the filter of VF DTL.	<input type="radio"/>	<input type="radio"/>
VF MODE					
COLOR VF MODE	AUTO	AUTO, ON	AUTO : Automatically recognizes the color VF to convert the VF VIDEO signal to R/G/B output. ON : Makes the VF VIDEO signal output R/G/B.	<input type="radio"/>	<input type="radio"/>
VF VIDEO SELECT	Y (² R/G/B)	Y, R, G, B, R+G+B, (R/G/B)	Sets the VF image output. R/G/B can be set in case the color VF is mounted or when the COLOR VF MODE is ON.	<input type="radio"/>	<input type="radio"/>
FRONT TALLY	ENABLE	ENABLE, DISABLE	Sets active/inactive for VF FRONT TALLY.	<input type="radio"/>	<input type="radio"/>

5.2 Settings from the Menu

Menu Item	Initial setting	Setting value	Description, Remarks	MENU DATA	
				ALL	VF
FOCUS ASSIST					
ASSIST AREA	TRIGGER ON	TRIGGER ON, ALWAYS ON, OFF	Sets the ASSIST AREA display. Select TRIGGER ON if you wish to display with the trigger of lens operation, etc.	×	×
TRIGGER	FOCUS	FOCUS, FOCUS/ZOOM, LENS VTR	Trigger to display ASSIST AREA. This setting is used when TRIGGER ON is selected.	×	×
AREA ON/OFF SW	NONE	VTR SW, EXT SW, NONE"	Selects the switch to turn ON/OFF the ASSIST AREA.	×	×
VF DOT BY DOT	UNLINK	LINK, UNLINK	Sets whether a control signal is sent to a VF having a DOT BY DOT display function.	×	×
FOR RET	ON	ON, OFF	Sets whether to display the ASSIST AREA or not when switching to the RET signal.	×	×
ASSIST DATA	NO.1	N0.1 to N0.4	Selects the ASSIST DATA compiled in the ASSIST DATA SETTING menu.	×	×
ASSIST DATA SETTING					
SW ACTION	ALTERNATE	ALTERNATE, MOMENTARY	If the trigger has been assigned to the LENS VTR SW, sets whether it is momentary operation or alternate operation.	○	○
AREA DISP TIME	1.0S	0.5S to 5.0S (0.5sec increments)	Sets the time from trigger detection until the focus assist area is erased.	○	○
AREA SIZE	15	0 to 100	Sets the focus assist area range. If set to "100", it is the entire screen domain.	○	○
AREA LEVEL	60%	25% to 100%	Sets the image level of the ASSIST AREA.	○	○
AREA COLOR	MONO	MONO, COLOR, NEGA	Sets whether the ASSIST AREA image should be color, monochrome or negative.	○	○
AREA MARKER	OFF	ON, OFF	Sets whether the assist area frame marker is displayed or not.	○	○
EDGE BOOST LEVEL	55	0 to 100	Sets the boost level of the edge signal.	○	○
EDGE COLOR	MONO	MONO, CYAN, MAGENTA, YELLOW, GREEN, RED, BLUE	Sets the color of the edge signal.	○	○
STORE DATA	---	N0.1 to N0.4	The contents set in the ASSIST DATA SETTING menu are stored as ASSIST DATA. Select the numbers you wish to store from No. 1 to No. 4 and write over the present data to store them.	-	-
MIC GAIN CONTROL					
MIC1 STEP	-40dB	+4dB, 0dB, -10dB, -20dB, -30dB, -40dB, -50dB, -60dB	The MIC1 gain is changed step by step.	○	×
MIC1 FINE	0	-100 to 100	Fine adjustment of the MIC1 gain. The gain decreases about -8 dB with -100, and increases about +8 dB with +100.	○	×
MIC2 STEP	-40dB	+4dB, 0dB, -10dB, -20dB, -30dB, -40dB, -50dB, -60dB	The MIC2 gain is changed stepwise.	○	×
MIC2 FINE	0	-100 to 100	Fine adjustment of the MIC2 gain. The gain decreases about -8 dB with -100, and increases about +8 dB with +100.	○	×
RETURN SELECT MODE					
RET-2/MIC SEL	RET-2	RET-2, MIC	Allocates a function to the RET-2/MIC button on top of handle and on left side of camera.	○	×
VTR SW SEL	RET-2	RET-2, MIC, FOCUS ASST	Sets a function to the VTR SW button on the lens. If the FOCUS ASSIST menu TRIGGER is set to LENS VTR, it becomes FOCUS TRIG fixed (information display).	○	×
RET PRIORITY	NOTHING	NOTHING, RET-1, RET-2	If a RET-1 or RET-2 image is not displayed in the viewfinder, sets the output signal to MON SDI (during RETURN setting). NOTHING : Sets to RET image last displayed in VF. RET1 : Sets to RET-1 image. RET2 : Sets to RET-2 image.	○	×
FILTER SERVO MODE					
SERVO CONT	SERVO	SERVO, MANUAL	SERVO : Sets to automatic control. MANUAL : Sets to manual control.	○	×

Menu Item	Initial setting	Setting value	Description, Remarks	MENU DATA	
				ALL	VF
SW FUNCTION					
RET-1 (HANDLE)	RET-1	RET-1, ZOOM-, FOCUS-, NONE	Sets the button control of RET-1 and RET-2/MIC on the top of the handle. When assigning to ZOOM, FOCUS, a serial lens is required.	○	×
RET-2 (HANDLE)	RET-2	RET-2, ZOOM+, FOCUS+, NONE		○	×
ZOOM SPEED	15	0 to 100	Sets the operational speed of ZOOM, FOCUS control. The speed is slower for "0" and faster for "100".	○	×
FOCUS SPEED	15	0 to 100		○	×
INFORMATION					
MPU MODULE SW	---	MPU substrate DIP SW	Displays the DIP switch settings of the MPU module.	-	-
WORKING TIME	---	*****H (information display)	Displays the total accumulated operation time of the camera up to the present.	-	-
SUB TIME	---	*****H (information display), RESET	Displays the camera's calculated operation time. Differs from WORKING TIME because it can be reset by the user.	-	-
VERSION	---	STRB600IV**:* (information display)	Number to control the structure of the camera software and FPGA. (Regarding the SDI-TRX, because it is on the FA side, it is not included in this control number).	-	-
MPU ROM	---	(information display)	Displays the camera software version.	-	-
D.PROC (PRE)	---				
D.PROC (POST)	---				
DRIVE PULSE	---	(information display)	Displays the FPGA version.	-	-
MPU	---				
SDI-TRX	---				

*1 : It is possible to determine when loading MENU DATA from the SD CARD whether to read the entire MENU or to read only items related to VF.
"○, ×" indicates the contents to be read at that time.

*2 : If the color VF is recognized automatically, the display switches to R/G/B.

MENU (2/4)

Menu Item	Initial setting	Setting value	Description, Remarks	MENU DATA	
				ALL	VF
VIDEO OUTPUT MODE					
SDI OUT	ON	ON, OFF	Turns the HD-SD signal (mainline) output ON/OFF.	○	×
MON SDI OUT	VF	VF, MAIN, RETURN	Switches the signals (HD-SDI) output from the MON SDI OUT connector. VF : Outputs same signals as VF images. MAIN : Outputs main line signals. RETURN : Outputs RET signals.	○	×
MON ANA OUT	MON	MON, SYNC	MON : Outputs micro-analog HD signals for monitor. SYNC : Outputs tri-level SYNC signals.	○	×
Q-TV ANA OUT	Q-TV1	Q-TV1, Q-TV2, VBS, OFF	Selects output signals from Q-TV output connector. VBS is the down convert signal of the main line signal.	○	×
AUX ANA OUT	VBS	VBS, Q-TV1, Q-TV2, OFF	Selects the output signal of the AUX output connector.	○	×
VBS CONFIG					
└ ASPECT	SQUEEZE	SQUEEZE, LETTER BOX, SIDE CROP	Sets the output of the down convert signal of the main line signal.	○	×
MID/HIGH GAIN MODE					
MID GAIN	-3dB	-6 to +12dB	Sets the medium gain value allocated to the M position of the GAIN SELECT switch.	○	×
HIGH GAIN	+6dB	-3 to +18dB	Sets the high gain value allocated to the H position of the GAIN SELECT switch.	○	×
BATTERY WARNING					
└ BATT WARN VOLT	11.0V	10.5 to 13.5V	Sets the battery voltage threshold to display warning.	○	×
BARS MODE					
BARS MODE	Destination setting	FULL, MULTI	FULL : Displays the BARS signal conventionally used. MULTI : Displays the multiformat BARS signal.	○	×
BARS ON	OFF	ON, OFF	Turns the color bar signal ON/OFF.	×	×
FAN CONTROL					
FAN CONT MODE	AUTO	AUTO, SLOW, QUIET, STOP	AUTO : Automatically changes the cooling fan speed according to the internal temperature level. SLOW : Sets the fan to SLOW for 5 minutes. After 5 minutes, the mode changes to AUTO. QUIET : Stops the fan until the external temperature becomes about 35°C. Above that temperature the fan is operated automatically. STOP : Keeps the fan stopped as long as the internal temperature does not reach a critical level. If the power is turned on again, it returns to AUTO. *If the QUIET, STOP modes are chosen, the surface temperature of the box may become higher than normal.	×	×
HEAD TOP	---	(information display)	SSLOW : Fan speed is very slow. SLOW : Fan speed is slow. NOR : Fan speed is normal. FAST : Fan speed is fast.	-	-
ADAPTOR	---				
VF CONT	---				
FAN CONDITION					
HEAD TOP	---	(information display)	OK : Normal NG : Fan is stopped.	-	-
ADAPTOR	---				
H PHASE CONTROL					
H PHASE	0.0	-100 to +100	Adjusts the horizontal phase when using external sync. Sets so that the phase of the internal SYNC signal matches the phase of the external SYNC signal. The internal SYNC advances in the direction of -100 in relation to the external sync, and delays in the direction of +100. *Can only be set during self-operation.	×	×
TIME SETTING					
TIME	---	HH : MM : SS	Sets the time and date when saving the file to the memory card.	-	-
DATE (YY/MM/DD)	---	YY / MM / DD			

Menu Item	Initial setting	Setting value	Description, Remarks	MENU DATA	
				ALL	VF
MEMORY CARD			See "5.3 Using the Memory Card" (P100) for the memory card usage method.		
SAVE FILE					
ALL DATA	---				
SNAP SHOT	---				
SCENE	---				
REFERENCE	---		Saves the selected data to the memory card.	-	-
LENS	---				
MENU DATA	---				
LOAD FILE					
ALL DATA	---			Loads all files.	-
SNAP SHOT	---		Loads snapshot files.	-	-
SCENE	---	ALL, SELECT NUMBER	Possible to select whether to load all from SCENE DATA or to load individual data from 1 to 8.	-	-
REFERENCE	---		Loads the reference file.	-	-
LENS	---	ALL, SELECT NUMBER	Possible to select whether to load all from LENS DATA or to load individual data from 1 to 8.	-	-
MENU DATA	---	ALL, VF	Possible to select whether to load all menus from MENU DATA or only those menus related to VF.	-	-

MENU (3/4)

Menu Item	Initial Setting	Setting Value	Description, Remarks	MENU DATA	
				ALL	VF
SCAN FORMAT SELECT					
SCAN MODE	Destination setting	1080I59, 720P59, 1080I50, 720P50	Selects the camera operation format. *If BS/CCU is connected, the format on the BS/CCU side and the operation format will be the same.	×	×
CPU SYSTEM CONTROL					
SEMI SELF MODE	ON	ON, OFF	ON : Will hold settings made by the operation control panel when the panel is disconnected. OFF : Will default back to camera head settings when operation control panel is removed.	○	×
SEMI REMOTE MODE	OFF	ON, OFF	ON : Allows GAIN, AWB, and SHUTTER/SUP-V to be set at the camera head when connected to a base station. OFF : Disables these functions at the camera head when connected to a basic station.	○	×
AUTO IRIS SET					
IRIS SET MODE	OFF	ON, OFF	ON: Enables auto-iris operation setting. *If set to ON, the iris adjustment from the operation control panel is disabled.	×	×
IRIS LEVEL SET	0	-100 to +100	Adjusts the convergence level of auto iris. Shoot the registration chart with the camera and adjust the value so that the video level becomes 75%.	×	×
PEAK RATIO SET	-70	-100 to +100	Shoot the gray scale chart with the camera and adjust the value so that the video level is 100%. Set the exposure for a bright area in the "+" direction and for a dark area in the "-" direction. The default value "50" indicates no exposure compensation.	×	×
IRIS GAIN	50	1 to 100	Sets the auto-iris response sensitivity characteristics. The auto-iris operation sensitivity is such that "1" is low and "100" is high. Hunting tends to occur more often as the value goes up. (Set it to the default value "50" as long as hunting is not occurring).	×	×
IRIS SPEED	50	1 to 100	Sets the response speed characteristics of the auto-iris. The auto-iris speed becomes slower for "1" and faster for "100".	○	×
IRIS LIMIT	F22	F22, F20, F18, F16	If the iris is about to close during auto-iris operation, it stops the iris operation before it completely closes to prevent iris hunting. Sets the iris limit value at that time.	○	×
LENS ADJUST	OFF	F16, F2.8, OFF	Sets the output of control voltage for fixed iris value during lens adjustment. To adjust the relationship between the lens control voltage value and lens iris value, the control voltage equivalent of F2.8 and F16 can be output to the lens.	×	×
AWB/ABB MODE					
AWB WITH A.IRIS	OFF	ON, OFF	Select whether A.IRIS is automatically input or not when executing AWB. *This menu is only valid during self-operation. It is always OFF during BS/CCU operation.	○	×
SMOOTH AWB	ON-0.5s	ON-0.3s, ON-0.5s, ON-0.7s, ON-1.0s, ON-1.5s, ON-2.0s, OFF	Switches Ach/Bch of AWB smoothly. Transition time of switching can be set.	○	×
AWB REFERENCE	ON	ON, OFF	ON : Converges the AWB convergence value to EXT AWB REF. OFF : Makes Rch/Bch correspond to Gch.	○	×
REFERENCE SET	ABB	ABB, AWB	Creates convergence value of AWB and ABB ^{*3}	×	×
AUTO WHITE SHADING	---	SET → START	Executes AWS(Auto White Shading). Makes Rch/Bch correspond to Gch White Shading. You must shoot a uniformly lit white surface.	-	-

Menu Item	Initial Setting	Setting Value	Description, Remarks	MENU DATA	
				ALL	VF
LENS SELECT					
NUMBER	OFF	NO.1 to NO.8, OFF	Select the lens file number. -If the lens code is obtained from the lens, (CODE SEL) is displayed on the back of the lens number display. -If AUTO SEL is ON, "AUTO SEL" is displayed on the back of the lens number display.	○	×
NAME	(-----)	12 characters	Set the file name for each lens file. Attaching the lens model name, etc. will make it easier to know the correspondence between the lens number and lens.	-	-
()	(-----)	AUTO SEL name display section	Displays the lens name obtained from the serial lens.	-	-
EXTENDER	OFF	ON-1, ON-2, ON-3, x0.8 CONV, OFF	Displays the extender state.	×	×
AUTO SEL	OFF	ON, OFF	The lens file number is switched automatically according to the model name obtained from the lens.	○	×
FILE SET	OFF	MANUAL, AUTO, OFF	See "5.2 Settings from the Menu [FILE SET]" (P94) for the FILE SET usage method.	×	×
LENS TYPE	OFF	C.PORTABLE, C.STUDIO, C.FIELD, F.PORTABLE, F.STUDIO, F.FIELD, OFF	To match the zoom tracking DTL operation characteristics with the lens zoom characteristics, set the time of the lens used in the camera. C.PORTABLE : Canon portable lens C.STUDIO : Canon studio lens C.FIELD : Canon field lens F.PORTABLE : Fujinon portable lens F.STUDIO : Fujinon studio lens F.FIELD : Fujinon field lens OFF : Game tracking DTL is OFF. Set by lens file (NO.1-8).	○	×
AUTO x0.8 CONV	OFF	ON, OFF	Set automatic switching of the aspect ratio converter (X0.8) internal lens. If set to ON, it operates in linked motion with the output aspect ratio of the down converter to carry out automatic switching.	○	×
X0.8 CONV CONT	OFF	ON, OFF	If turned ON when using the X0.8 converter internal lens, control is possible. When not using the X0.8 converter internal lens, set to OFF.	○	×
LENS SERIAL I/F	ON	ON, OFF	Set whether to respond to the serial interface of the lens or not.	○	×
LEVEL ADJUST					
MASTER GAMMA	0.0	-100 to +100	Sets the master gamma value. The gamma value decreases in the direction of "-100" and increases in the direction of "+100".	×	×
MASTER PED	0.0	-100 to +100	Sets the master pedestal value. The pedestal value decreases in the direction of "-100" and increases in the direction of "+100".	×	×
MASTER FLARE	0.0	-100 to +100	Sets the master flare value. The flare value decreases in the direction of "-100" and increases in the direction of "+100".	×	×
DTL GAIN	0.0	-100 to +100	Sets the detail amount. The detail amount decreases in the direction of "-100" and increases in the direction of "+100".	×	×
ADJ CLR	READY	READY, PUSH SET→CLR, CANCEL	Returns the settings changed with LEVEL ADJUST to the state prior to change as a group.	-	-
PROCESS MODE					
SMOOTH STEP GAIN	ON-0.5s	ON-0.3s, ON-0.5s, ON-0.7s, ON-1.0s, ON-1.5s, ON-2.0s, OFF	Changes the STEP GAIN step by step. Possible to choose the time until convergence.	○	×
SMOOTH STEP ECC	ON-0.5s	ON-0.3s, ON-0.5s, ON-0.7s, ON-1.0s, ON-1.5s, ON-2.0s, OFF	Changes the STEP ECC step by step. Possible to choose the time until convergence.	○	×
MATRIX	OFF	1, 2, 3, OFF	There are independent settings for three channels of the matrix, which can be switched.	×	×
ADVANCED MATRIX	OFF	ON, OFF	Sets the ON/OFF of advanced matrix.	×	×
HI-LIGHT DTL	ON	ON, OFF	Possible to increase the DTL level of the highlight part.	×	×
GAIN	0.0	0 to 100	Sets the level value to be emphasized. Level increases in the direction of +100.	×	×
LIMIT	0.0	-100 to +100	Sets the upper limit for the emphasized DTD level. The "-100" direction lowers the limit. The "+100" direction raises the limit and lowers the DTL level.	×	×

Menu Item	Initial Setting	Setting Value	Description, Remarks	MENU DATA	
				ALL	VF
SMOOTH KNEE	TYPE-1	TYPE1, TYPE2, TYPE3, OFF	SMOOTH KNEE is a function to adjust the compression level of the brightness signal with KNEE. It can be selected from the following three setting types. TYPE1 : The compression rate of brightness is low. TYPE2 : The compression rate of brightness is medium. TYPE3 : The compression rate of brightness is high.	×	×
DTL V FILTER	OFF	ON, OFF	If the V filter of the DTL is ON, the resolution in direction V diminishes, making it possible to obtain an image with less noise.	○	×
PRESET FILE LOAD			Function to load the user settings (ENGINEER SET FILE) or factory settings (FACTORY SET FILE) for the level adjustment or menu of the camera. Used to return the camera state back to the previous or initial settings.		
FILE SELECT	ENGINEER	ENGINEER, FACTORY	ENGINEER : Initializes the state back to the user setting. FACTORY : Initializes the state back to the initial factory setting.	×	×
LOAD START	READY	READY, START, CANCEL	Executes initialization.	-	-

*3 : When compiling ABB/AWB reference files from the menu, No. 2 of S3 of the MPU module must be turned ON.
When changing the switch, be sure to first turn the power OFF.
After compiling the reference file, be sure to return No. 2 of S3 to OFF.
When compiling the reference file from the control panel, it is not necessary to turn this switch ON.

■ MENU (4/4)

Menu Item	Initial Setting	Setting Value	Description, Remarks	MENU DATA	
				ALL	VF
INCOM SETUP					
┌ RECEIVE					
├ INCOM1 L/R CH					
├ INCOM1	BOTH	BOTH, LEFT, RIGHT	Do the Assignment Settings to the head set of INCOM1 channel.	○	×
├ INCOM2	BOTH	BOTH, LEFT, RIGHT	Do the Assignment Settings to the head set of INCOM2 channel.	○	×
├ PGM1	BOTH	BOTH, LEFT, RIGHT	Do the Assignment Settings to the head set of PGM1 channel.	○	×
├ PGM2	BOTH	BOTH, LEFT, RIGHT	Do the Assignment Settings to the head set of PGM2 channel.	○	×
├ INCOM2 L/R CH					
├ INCOM1	BOTH	BOTH, LEFT, RIGHT	Do the Assignment Settings to the head set of INCOM1 channel.	○	×
├ INCOM2	BOTH	BOTH, LEFT, RIGHT	Do the Assignment Settings to the head set of INCOM2 channel.	○	×
├ PGM1	BOTH	BOTH, LEFT, RIGHT	Do the Assignment Settings to the head set of PGM1 channel.	○	×
├ PGM2	BOTH	BOTH, LEFT, RIGHT	Do the Assignment Settings to the head set of PGM2 channel.	○	×
└ PGM FRONT VR	PGM1	PGM1, PGM2	Choose a signal to control by the PGM volume of the camera right side surface.	×	×
MENU MODE					
└ ENGINEER MENU	OFF	OFF, ON	Set to ON to display the ENGINEER menu. *If the camera power is turned OFF, this menu setting returns to OFF.	×	×

ENGINEER (1/2)

Menu Item	Initial Setting	Setting Value	Description, Remarks	MENU DATA	
				ALL	VF
AUTO DPC					
DPC	ON	ON, OFF	Turns on/off all data with defective pixel correction. ON : Enable all data with defective pixel correction. OFF : Disable all data with defective pixel correction.	×	×
DETECT MODE	WHT+BLK	WHT+BLK, WHITE, BLACK	Sets the mode of defective pixel correction. WHT + BLK : Simultaneously corrects white and black defective pixels. WHT : Corrects white defective pixels only. BLK : Corrects black defective pixels only.	×	×
SAMPLE AREA SET			Sets the WINDOWS cursor for defective pixel correction.	-	-
AUTO DPC			If this item is selected, automatic detection and automatic correction are performed for defective pixel correction.	-	-
DPC EFFECT CHK	OK	OK, CANCEL	You can check the correction of defective pixels in all setting ranges.	-	-
DPC CLEAR	OK	OK, CANCEL	Deletes all correction data for defective pixel correction.	-	-
SAMPLE GUIDE LINE	ALL ON	ALL ON, H ON, V ON, ALL OFF	Selects display/hide and types of auxiliary line on WINDOWS cursor in "SAMPLE AREA SET".	○	×
AREA SELECT SPEED	FAST	FAST, NORMAL	Sets the moving speed of WINDOWS cursor in "SAMPLE AREA SET".	×	×
FIBER SINGLE MODE CONT					
SINGLE MODE	OFF	ON, OFF	Supplies power from DC connector of adapter when BS/CCU is connected. In this case, stops power supply from an optical cable. If it is sets to "ON," the mode is switched to the single fiber mode.	○	×
CAMERA ID SETUP					
PROGRAM NO.	1	1 to 99, OFF	You can set the camera No. at the time of program operation, etc. If the camera No. is set on the operation control panel side, the ID No. that has been set is displayed. Reversely, if the camera No. is set on the camera side, the ID No. that has been set is displayed on the operation control panel.	×	×
ID NO.	1	1 to 40	Sets ID No. of camera. Sets this when you want the camera No. to be detected and displayed on the BS/CCU side.	×	×
MATRIX PRESET DATA					
MATRIX 1	Destination setting	OFF, SMPTE, EBU, ITU-709, (USER1, USER2)	Selects the preset of color matrix. * In order to select USER1 and 2, you must turn on "MATRIX USER1(2) DATA SET - DATA SET MODE".	○	×
MATRIX 2	Destination setting	OFF, SMPTE, EBU, ITU-709, (USER1, USER2)		○	×
MATRIX 3	Destination setting	OFF, SMPTE, EBU, ITU-709, (USER1, USER2)		○	×
MATRIX USER1 DATA SET					
DATA SET MODE	OFF	ON, OFF	Sets the preset (USER1) of color matrix. ON : Sets the preset data. OFF : Does not set the preset data.	-	-
R-G	0.0	-100 to +100	Sets the matrix of R-G.	○	×
R-B	0.0	-100 to +100	Sets the matrix of R-B.	○	×
G-R	0.0	-100 to +100	Sets the matrix of G-R.	○	×
G-B	0.0	-100 to +100	Sets the matrix of RG-B.	○	×
B-R	0.0	-100 to +100	Sets the matrix of B-R.	○	×
B-G	0.0	-100 to +100	Sets the matrix of B-G.	○	×
DATA CLEAR	---	READY	READY : Normal status PUSH SET → CLR: Clears the preset data. CANCEL : Exit "DATA CLEAR" without clearing the settings.	-	-

Menu Item	Initial Setting	Setting Value	Description, Remarks	MENU DATA	
				ALL	VF
MATRIX USER2 DATA SET					
			Sets the preset (USER2) of color matrix.		
DATA SET MODE	OFF	ON, OFF	ON : Sets the preset data. OFF : Does not set the preset data.	-	-
R-G	0.0	-100 to +100	Sets the matrix of R-G.	○	×
R-B	0.0	-100 to +100	Sets the matrix of R-B.	○	×
G-R	0.0	-100 to +100	Sets the matrix of G-R.	○	×
G-B	0.0	-100 to +100	Sets the matrix of RG-B.	○	×
B-R	0.0	-100 to +100	Sets the matrix of B-R.	○	×
B-G	0.0	-100 to +100	Sets the matrix of B-G.	○	×
DATA CLEAR	---	READY	READY : Normal status PUSH SET → CLR: Clears the preset data. CANCEL : Exit "DATA CLEAR" without clearing the settings.	-	-
INCOM SETUP (ENG)					
HEADSET					
INCOM1	CARBON	CARBON, DYNAMIC	Selects carbon or dynamic for INCOM microphone.	×	×
INCOM1 POWER	ON	ON, OFF	Sets the ON/OFF of the power supply to dynamic microphone. (Fixed to ON when ICOM1 is set to CARBON.)	○	×
INCOM1 GAIN	NORMAL	NORMAL, HI	Sets the GAIN of the dynamic microphone when "CARBON" is selected in ICOM1.	×	×
INCOM2	CARBON	CARBON, DYNAMIC	Selects carbon or dynamic for INCOM microphone.	×	×
INCOM2 POWER	ON	ON, OFF	Sets the ON/OFF of the power supply to dynamic microphone. (Fixed to ON when ICOM2 is set to CARBON.)	○	×
INCOM2 GAIN	NORMAL	NORMAL, HI	Sets the GAIN of the dynamic microphone when "CARBON" is selected in ICOM2.	×	×
RECEIVE					
INCOM1 L/R CH					
INCOM1	BOTH	BOTH, LEFT, RIGHT	Sets the assignment of INCOM1 channel to headsets.	○	×
INCOM2	BOTH	BOTH, LEFT, RIGHT	Sets the assignment of INCOM2 channel to headsets.	○	×
PGM1	BOTH	BOTH, LEFT, RIGHT	Sets the assignment of PGM1 channel to headsets.	○	×
PGM2	BOTH	BOTH, LEFT, RIGHT	Sets the assignment of PGM2 channel to headsets.	○	×
INCOM2 L/R CH					
INCOM1	BOTH	BOTH, LEFT, RIGHT	Sets the assignment of INCOM1 channel to headsets.	○	×
INCOM2	BOTH	BOTH, LEFT, RIGHT	Sets the assignment of INCOM2 channel to headsets.	○	×
PGM1	BOTH	BOTH, LEFT, RIGHT	Sets the assignment of PGM1 channel to headsets.	○	×
PGM2	BOTH	BOTH, LEFT, RIGHT	Sets the assignment of PGM2 channel to headsets.	○	×
EARPHONE					
INCOM1	ON	ON, OFF	If it is set to ON, INCOM1 signal is outputted from EARPHONE connector on the back side of camera.	○	×
INCOM2	OFF	ON, OFF	If it is set to ON, INCOM2 signal is outputted from EARPHONE connector on the back side of camera.	○	×
PGM SELECT	OFF	INC1, INC2, OFF	INC1 : PGM1 signal and PGM2 signal are outputted from EARPHONE connector on the back of camera, and the volume can be adjusted by the INCOM1 PGM volume on the back of camera. INC2 : PGM1 signal and PGM2 signal are outputted from EARPHONE connector on the back of camera, and the volume can be adjusted by the INCOM2 PGM volume on the back of camera.	○	×

5.2 Settings from the Menu

Menu Item	Initial Setting	Setting Value	Description, Remarks	MENU DATA	
				ALL	VF
INCOM MODE	NORMAL	NORMAL, CROSS, ILINE ENG, USA, USER1, USER2	Sets the connection (preset setting) of INCOM line.	×	×
INCOM MODE SETUP			Sets the connection for when USER1/USER2 is selected in INCOM MODE PRESET.		
DATA LOAD	READY	READY, NORMAL, CROSS, ILINE ENG, USA, USER1, USER2, CANCEL	Load the setting that becomes a base of the setting.	-	-
INCOM1 MIX	ENG	ENG, PRD, BOTH, SW LINK, OFF	Selects the line such that whether TALK line of INCOM1 is linked to ENG line, PROD line, both lines, or SW on the back side, etc. *4	○	×
INCOM2 MIX	PRD	ENG, PRD, BOTH, SW LINK, OFF	Selects the line such that whether TALK line of INCOM2 is linked to ENG line, PROD line, both lines, or SW on the back side, etc. *4	○	×
INCOM1 -> INCOM2	OFF	ON, OFF	Connects TALK line of INCOM1 to INCOM2.	○	×
INCOM1 <- INCOM2	OFF	ON, OFF	Connects TALK line of INCOM2 to INCOM1.	○	×
AFTER VR MIX					
INCOM1 -> INCOM2	OFF	ON, OFF	Connects TALK line of INCOM1 to INCOM2.	○	×
INCOM1 <- INCOM2	OFF	ON, OFF	Connects TALK line of INCOM2 to INCOM1.	○	×
DATA SAVE	READY	READY, USER1, USER2, CANCEL	Saves data as USER1 or USER2.	-	-
PGM FRONT VR	PGM1	PGM1, PGM2	Selects the signal to be controlled by PGM volume on the right side of camera.	×	×
PGM SETUP					
PGM LEVEL	LOW	NORMAL, LOW	Sets the output level of PGM. (Reduced by 10 dB with LOW)	○	×
PGM2 OUT PGM2	ON	ON, OFF	Sets the ON/OFF for outputting PGM2 signal to PGM2.	○	×
PGM2 OUT PGM3	OFF	ON, OFF	Sets the ON/OFF for outputting PGM3 signal to PGM2.	○	×
PGM2 OUT MIC1	OFF	ON, OFF	Sets the ON/OFF for outputting MIC1 signal to PGM2.	○	×
PGM2 OUT MIC2	OFF	ON, OFF	Sets the ON/OFF for outputting MIC2 signal to PGM2.	○	×
BELT PACK(OPTION)					
INCOM1 B.P	OFF	ON, OFF	Turns on when the belt pack is connected to INCOM1.	×	×
INCOM2 B.P	OFF	ON, OFF	Turns on when the belt pack is connected to INCOM2.	×	×
ENGINEER SET FILE RENEW					
DATA RENEW MODE			Saves the conditions of camera level adjustment and menu. The saved data can be loaded as user settings data of "PRESET FILE LOAD" in MENU(3/4).	-	-

*4 : Selection switch on the rear panel of the MIC line typically controls only the TALK line, but SW LINK to be selected TALK line and LISTEN line both can be controlled.

ENGINEER (2/2)

Menu Item	Initial Setting	Setting Value	Description, Remarks	MENU DATA	
				ALL	VF
PROCESS ENABLE					
└─ COLOR CORR	ENABLE	ENABLE, DISABLE	ENABLE : Enables control from the panel.	<input type="radio"/>	<input type="checkbox"/>
└─ CUSTOM COL1	ENABLE	ENABLE, DISABLE	DISABLE : Disables control from the panel (Also disables ON/OFF of processing and analog control.)	<input type="radio"/>	<input type="checkbox"/>
└─ CUSTOM COL2	ENABLE	ENABLE, DISABLE		<input type="radio"/>	<input type="checkbox"/>
└─ PROGRAM UPDATE	ENABLE	ENABLE, DISABLE	ENABLE : Enables ROM update from the panel. DISABLE : Disables ROM update from the panel.	<input type="radio"/>	<input type="checkbox"/>
VF CONT					
└─ RETURN ON CONT	ON	ON, OFF	Sets whether the RETURN control signal is sent to VF or not. Zoom operation is not effective when RETURN is ON.	<input type="radio"/>	<input type="checkbox"/>
HD SDI TRUNK SETTING					
└─ EMB .AUDIO OUT	---	--- (ON, OFF)	Sets the addition of EMB signal to HD-SDI TRUNK signal. However, this can be selected only when FA-97A is connected.	<input type="radio"/>	<input type="checkbox"/>
HD SDI OUT					
└─ COLOR FILTER	LPF4	LPF1, LPF2, LPF3, LPF4	Sets the frequency band of color difference signal (P b, P r) for HD SDI signal. The LPF1 is narrow band, and LPF2 and LPF3 are wider bands in the respective order. LPF 4 (standard value) is the widest band.	<input type="radio"/>	<input type="checkbox"/>
OPTICAL ABERRATION CORR.					
└─ CORRECTION	ENABLE	ENABLE, DISABLE	Switches Enable/Disable of aberration correction. This setting is also saved when the power is turned off. Therefore, set it to DISABLE if aberration correction is not used.	<input type="radio"/>	<input type="checkbox"/>
└─ CORR. LEVEL	0	-10 to 10	Controls the level of correction.	<input type="radio"/>	<input type="checkbox"/>
└─ OAC GUIDE MARK	ON	ON, OFF	Sets whether a reminder to be shown on the VF or not when the aberration correction value is not properly received from the serial lens.	<input type="radio"/>	<input type="checkbox"/>
VIDEO MAINTENANCE MODE					
└─ Q-TV MODE(50Hz)	9MHz x 1ch	6MHz x 2ch, 4.5MHz x 2ch, 9MHz x 1ch	Sets the Q-TV transmission mode when the operation frequency is 50 Hz. Fixed to 1 ch when the operation frequency is 59.94 Hz.	<input type="radio"/>	<input type="checkbox"/>
PROGRAM UPDATE					
└─ FILE SELECT	---		Updates all programs. (SOFT & DPROC FPGA & DRIVE POLSE FPGA) * The package VERSION is updated by this update.	-	-

FILE SET

FILE SET creates a lens file.

To change the settings, select "LENS SELECT" on MENU (3/4), then "FILE SET".

The following explains the set values, descriptions, and setting procedures.

Set Value	Description
OFF (default)	Does not create lens files.
MANUAL	Stores the current lens status as a file. ("LENS No. x" will be displayed at the bottom of the screen.)
AUTO	Starts auto setup for lens file creation. ("PUSH SET -> START" will be displayed and flash at the bottom of the screen.)

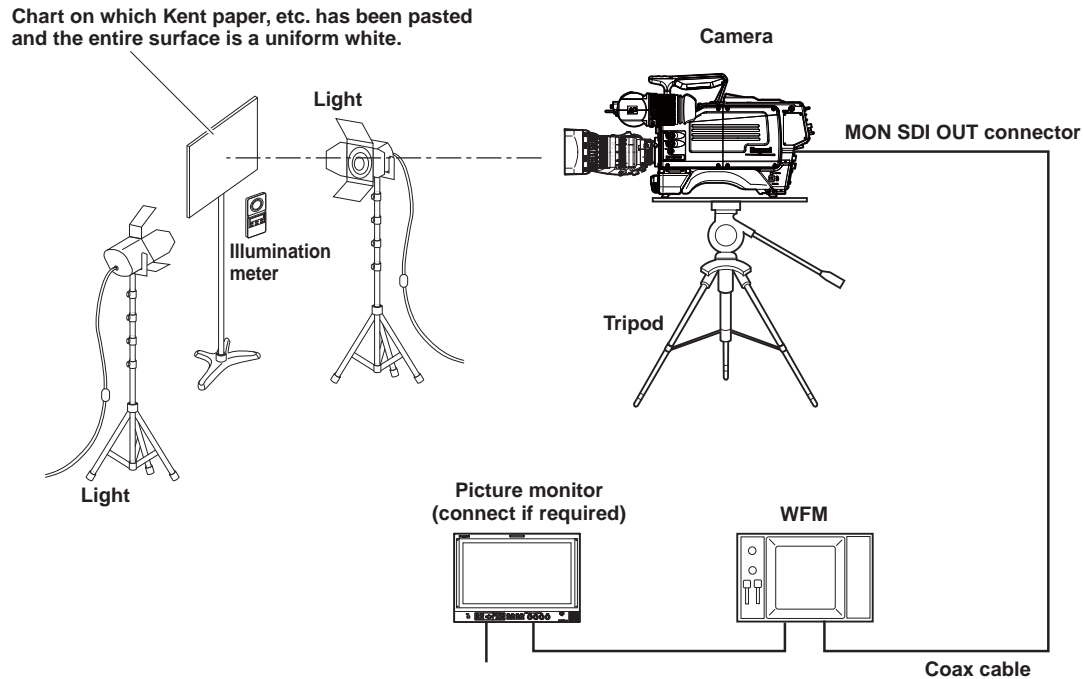

Note:

- The creation of lens file requires precise adjustment; therefore, lens files are protected against unintentional update by the S3-4 DIP switch of the MPU module.
- When creating a lens file, set the optical filter to ND:100% and the ECC filter to 3200K. Also confirm that no special effect filter is attached to the front of the lens or internal filter disk. If a special effect filter is attached, it may not be possible to correctly create the lens file.
- When operating the DIP switch (S3) in the MPU module, turn the POWER switch of the camera OFF once.

1

Set the camera for level setup.

- Mount the standard lens, which is used as a reference lens, to the camera.
- Chart on which Kent paper, etc. has been pasted and the entire surface is uniform white.
- Use an illumination meter to adjust the light so that light is evenly distributed over the whole chart.

2

Dip switch S3-4 On allows creation of a lens file, Off prohibits creation of new lens files.

- 3** On MENU (3/4), turn the rotary pulse switch to position the cursor on "LENS SELECT," and press the SET button.

The submenu is displayed.

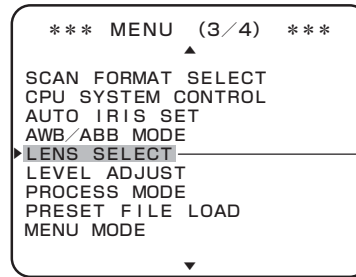

③ position the flashing cursor on and confirm.

- 4** Set "NUMBER", "NAME" and "EXTENDER".

Refer to the explanation of corresponding item for how to set each data.

NO. 1 is selected here as an example.

CAUTION:

If a new file is created with the same file number as an existing file, the data will be overwritten and the old data will be lost.

- 5** Turn the rotary pulse switch to position the cursor on "FILE SET," and press the SET button.

The cursor moves to the mode selection column.

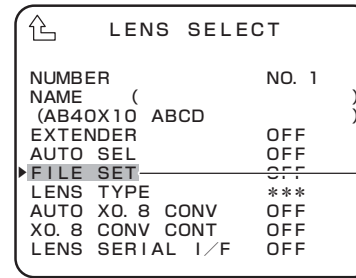

⑤ position the cursor on and

- 6** Turn the rotary pulse switch to select the set value, and press the SET button.

The value is confirmed, and either of the following messages is displayed at the bottom of the screen:

- LENS No. x : Displayed when "MANUAL" is selected.
- PUSH SET -> START : Displayed and flashes when "AUTO" is selected.

Go to Step 7 when "AUTO" is selected.

When "MANUAL" is selected, go to Step M1 to obtain the model name of the lens after lens file items such as GAIN/FLARE/GAMMA are adjusted by MCP, etc.

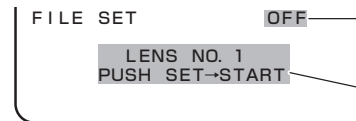

⑥ select the set value and confirm.
⑦ either message is displayed or flashes.

- 7** Press the SET button.

The lens file is created.

- 8** Set the S3-4 DIP switch of the MPU module back to "OFF."

Note:

- When the camera is powered OFF, the FILE SET settings are turned OFF.
- Before creating lens files, prepare all the lenses to use. Then, create the files under the same condition at a time. If the conditions are changed, the setting cannot be accurate. Lens files memorize a difference in level between lenses. If the lighting or chart is changed, it cannot tell whether it is the lighting error, chart error, or lens error.

5

M1 Turn the rotary pulse switch to position the cursor on the AUTO SEL NAME display part (AB40X10 ABCD), and press the SET button.

The screen switches to a display for obtaining a new model number from the lens, and the letters "CANCEL" flash.

Note:

"(AB40X10 ABCD)" is used here for an example of the model name automatically and previously obtained from the lens.

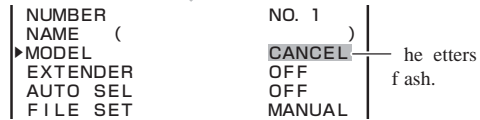
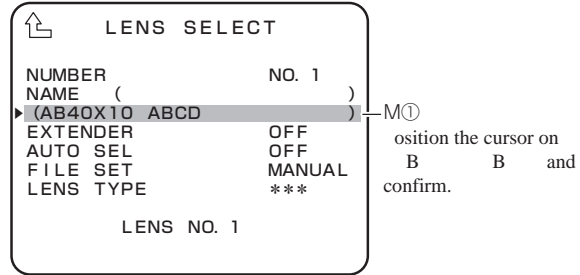

M2 Turn the rotary pulse switch to switch the cursor on "CANCEL" to "AUTO READ," and press the SET button.

- "COMPLETED" appears on the bottom.

- When "COMPLETED" disappears, a newly loaded model name will appear.

Note:

"(BB40X10 BCDE)" is used here for an example of the model name automatically and newly obtained from the lens.

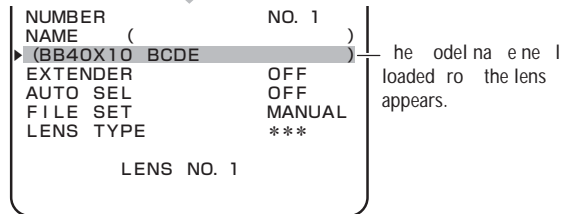
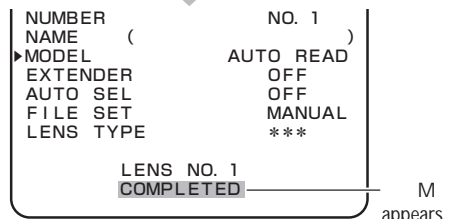
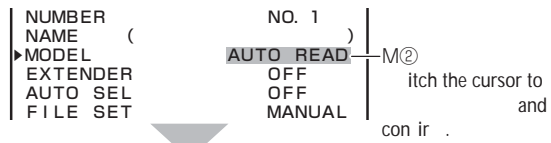

M3 Turn the rotary pulse switch to position the cursor on "FILE SET," and press the SET button.

The cursor moves to the mode selection column.

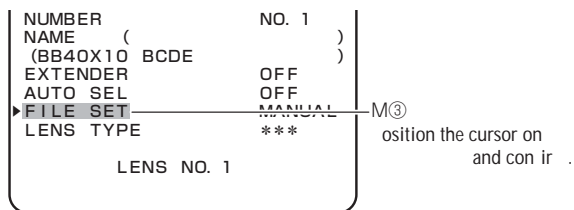

M4 Turn the rotary pulse switch to switch the cursor on "MANUAL" to "OFF," and press the SET button to complete the lens file creation. Then, go to Step 8.

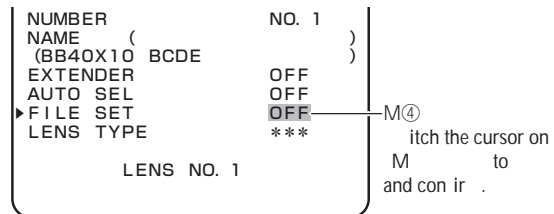

Note:

- When the new model name cannot be loaded from the lens, "READ ERROR" appears on the bottom instead of "COMPLETED."

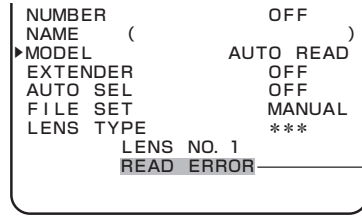

When the new model name cannot be loaded

- When the rotary pulse switch is turned to switch the cursor on "CANCEL" to "CLR" and the SET button is pressed in Step M2, "COMPLETED" appears on the bottom.

Next, when "COMPLETED" disappears, the area to display a model name automatically obtained from the lens will be blank.

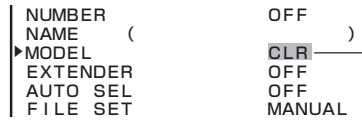

Switch the cursor to CLR and confirm.

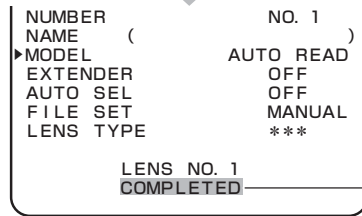

M appears.

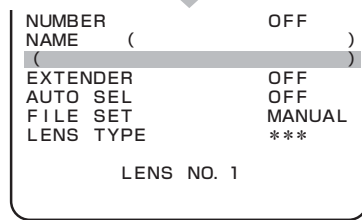

The area will be blank.

Note:

The lens name used for "AUTO SEL" can be edited so that the lens file can be shared with a similar lens. The following explains the procedures.

E1

Follow Steps 1 to 3 of lens file creation to display the submenu.

E2

Turn the rotary pulse switch to position the cursor on "NUMBER", and press the SET button.

The registered lens numbers (NO. 1 to NO. 8) are displayed.

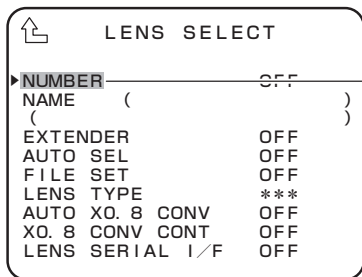

E2: Position the cursor on NUMBER and confirm.

E3

Turn the rotary pulse switch to position the cursor on the lens number of the file name to be edited, and press the SET button.

The NO.5 lens set in "AUTO SEL" is selected here as an example and the AUTO SEL NAME display part displays "AB40X10 ABCD".

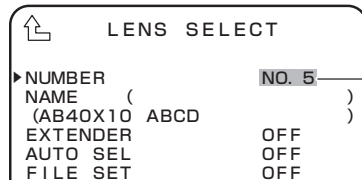

E3: Select the target lens number and confirm.

E4 Turn the rotary pulse switch to position the cursor on "FILE SET", and press the SET button.
The cursor moves to the mode selection column.

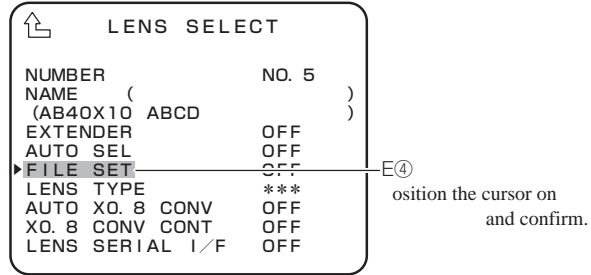

E5 Turn the rotary pulse switch to position the cursor on "MANUAL", and press the SET button.

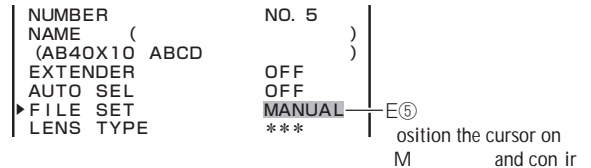

E6 Turn the rotary pulse switch to position the cursor on the AUTO SEL NAME display part, and press the SET button.
The item changes to "MODEL", and the letters "CANCEL" flash.

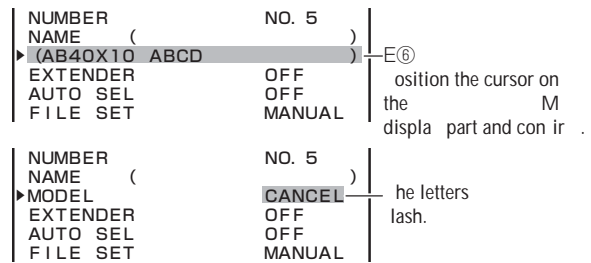

Reference:

If "AUTO SEL NAME" is not set, the AUTO SEL NAME display part does not display the lens model name.
Connect the target lens, perform "AUTO READ", and then follow the procedures below.
Refer to Steps M1 and M2 for performing "AUTO READ".

E7 Turn the rotary pulse switch to switch the cursor from "CANCEL" to "EDIT", and press the SET button.
The under submenu "AUTO SEL NAME EDIT" is displayed.

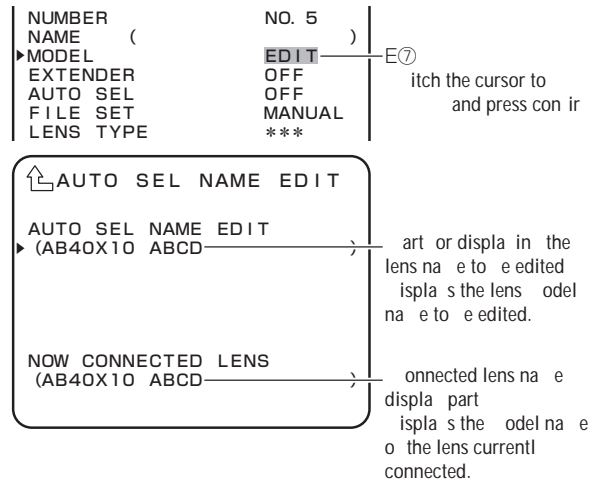

E8 Turn the rotary pulse switch to position the cursor on the part for displaying the lens name to be edited, and press the SET button.
The item changes to the edit mode and () at both ends flash.

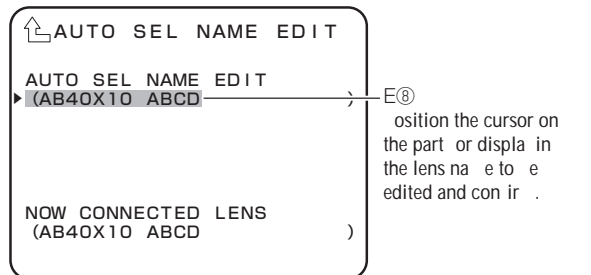

- E9** Turn the rotary pulse switch to edit the lens name. Use "*" for the characters that are not to be compared in "AUTO SEL".

"AB40X10 A" are to be compared and the following "BCD" are not to be compared here as an example. Editing the lens name in this way allows you to apply the same lens file to the following two lenses.
 - "AB40X10 ABCD"
 - "AB40X10 AEFG"

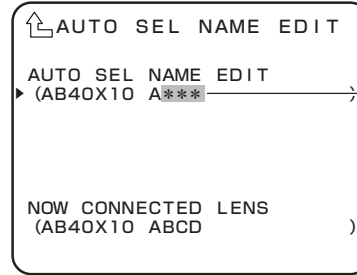

E⑩
change the characters
not to be compared to
and confirm.

- E10** After editing the lens name, press the SET button and confirm.

The edit mode is terminated and () at both ends stop flashing.
 Now go to Step M3.

CAUTION:

1. The processing for "AUTO READ" is as follows:
 - * When a serial lens is connected
 The model name of the serial lens currently connected is set for "AUTO SEL NAME".
 - * When no lens is connected or an analog lens is connected
 The registered "AUTO SEL NAME" is retained.
2. "AUTO SEL NAME EDIT" can be set regardless of whether a lens is connected or not.
3. "AUTO SEL NAME EDIT" is a function to edit the model name read through "AUTO READ".
4. This function is not available if the model name of the target serial lens has not been obtained through "AUTO READ".

5.3 Using the Memory Card

The memory card can be used to store/read the setting condition of the camera.

For the memory card, it is possible to use the SD/SDHC memory card with the following specifications.

- Memory capacity : SD card from 32 MBytes to 2 GBytes.
SDHC card from 4 GBytes to 32 GBytes.
- Format : Format meeting standards of SD/SDHC memory card.

CAUTION:

Market-sold memory cards have undergone sufficient confirmation of operation at this company. However, we cannot assume any responsibility for guaranteeing operation.

■ Inserting and removing the memory card

There is a memory card slot as shown in the illustration below on the bottom left side of the camera main unit.

Open the dustproof cover and insert the memory card in the memory card slot.

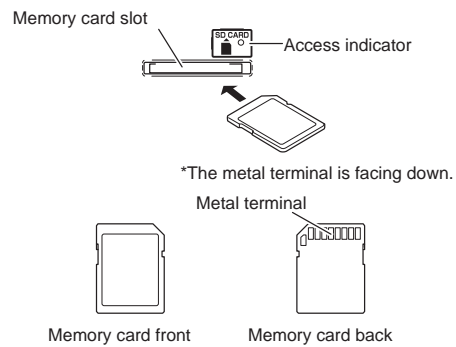
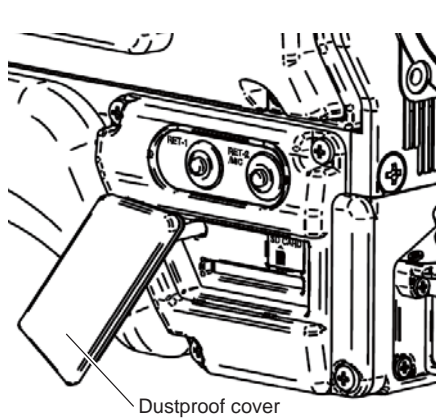

CAUTION:

When inserting the memory card in the slot, be sure that the memory card is facing in the correct direction.

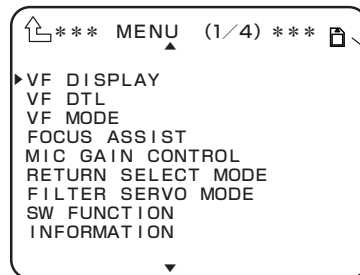

If the camera is recognizing the memory card normally, the memory card mark is displayed in the upper right of the menu screen.

When removing the memory card from the card slot, gently press the memory card until there is a clicking sound and then carefully remove the card.

■ Storing the camera setting state on the memory card

Store the camera setting state on the memory card. First confirm that the write protect switch of the memory card is not on the LOCK side.

- 1 Turn the rotary pulse switch on MENU (2/4), set the cursor to [MEMORY CARD] and press the SET button.

The submenu is displayed.

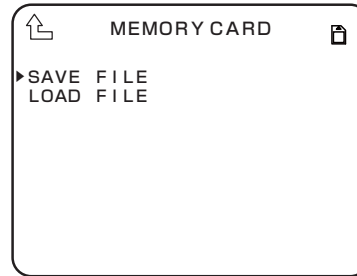

- 2 Select [SAVE FILE] and press the SET button.

The SAVE FILE submenu is displayed.

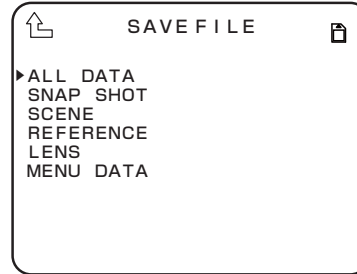

- 3 Select the item from the SAVE FILE submenu that you wish to save.

Select ALL DATA on the picture.

- 4 After selecting the item you wish to save, press the SET button. Then use the rotary pulse switch and SET button to insert an eight-character file name. When the eight character file name has been determined, [PUSH SET -> START] is displayed on the cursor.

Press the SET button. If a file of the same file name exists on the memory card at this time, proceed to step M1. If you wish to cancel, turn the rotary pulse switch when [PUSH SET -> START] is displayed.

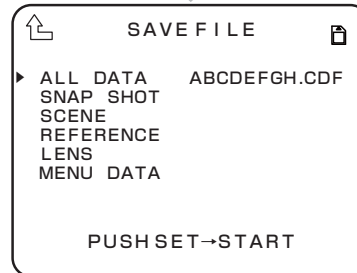

- 5 When the file is being saved, [SAVING FILE] is displayed. If the file is saved normally, [COMPLETE] is displayed.

CAUTION:

Never remove the memory card from the slot during display of [SAVING FILE] or while the access indicator is lighted, as data is being written to the memory card. Removing it at this time could damage the memory card data or the memory card itself.

M1 If a file with the same file name exists on the memory card, a message is displayed asking whether it is all right to write over the data. To enable writing over of data, change [NO] to [YES] and press the SET button. If [NO] has been selected, storage is cancelled and the system returns to step [3].

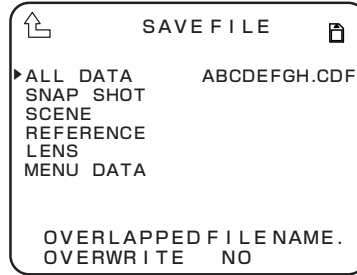

Note:

The images of the storage range for files are shown in the figure below.

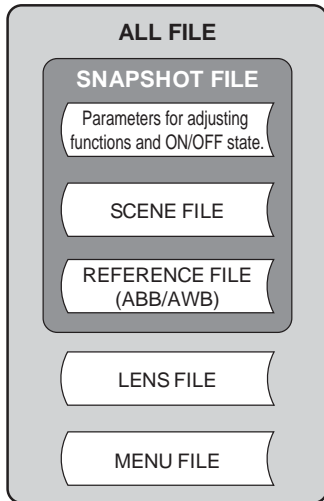

■ Reading the camera setting condition from the memory card.

Read the camera setting condition from the memory card.

- 1 Turn the rotary pulse switch on MENU (2/4) to adjust the cursor to [MEMORY CARD] and press the SET button.

The submenu is displayed.

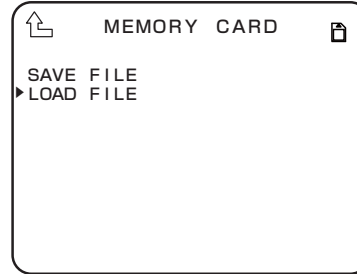

- 2 Select [LOAD FILE] and press the SET button.

The LOAD FILE submenu is displayed.

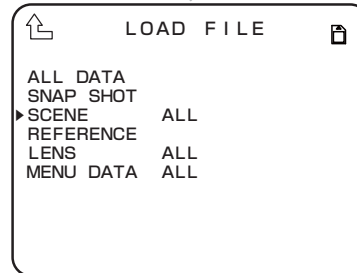

- 3 Select the item you which to read to the camera from the LOAD FILE submenu.

In the figure, [SCENE] is selected.

- 4 After selecting the item to be read to the camera, press the SET button.

Then select whether to read all files or individual files from No. 1 to No. 8. In the example in the figure, No. 8 is selected. Then select a file stored on the memory card.

After the contents are determined, [PUSH SET -> START] is displayed. Press the SET button.

If you wish to cancel, turn the rotary pulse switch when [PUSH SET -> START] is displayed.

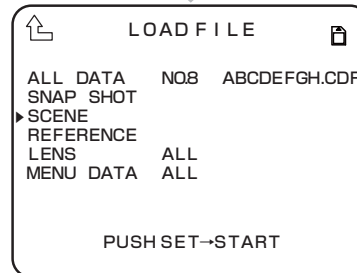

Note:

SCENE FILE, LENS FILE, MENU DATA is about, it is possible to select individual data (ALL) or all data.

-SCENE : ALL, NO.1-NO.8

-LENS FILE : ALL, NO

-MENU DATA : ALL, VF

- 5 When the file is being saved, [SAVING FILE] is displayed. If the file is saved normally, [COMPLETE] is displayed. If ALL FILE and MENU DATA have been read, the camera is automatically restarted after display of [COMPLETE].

CAUTION:

Never remove the memory card from the slot during display of [SAVING FILE] or while the access indicator is lighted, as data is being written to the memory card. Removing it at this time could damage the memory card data or the memory card itself.

CAUTION:

If changes as those listed below have been made in the file name stored to a PC, etc., it is not possible to display the file name normally.

-If a file name with more than 8 characters has been set.

-Using file names (kanji, kana, etc.) composed of characters other than half-size letters of the alphabet.

■ Error Messages

If an error is generated when saving or reading files, various error messages are displayed. The error messages and contents are as shown below.

Error Message	Contents
NO CARD	Memory card not inserted.
CANNOT OPEN FILE	File cannot be opened.
NOT CAMERA DATA FILE.	Not a camera data file.
FILE OF DIFFERENT CAMERA.	Different type of file.
RELEVANT DATA IS NOT FOUND.	Relevant data cannot be found.
WRITE ERROR	Write error.
READ ERROR	Read error.
ERROR	Other error.

TROUBLE SHOOTING and MAINTENANCE



Refer to this chapter when the alarm lamp lights or when you want to know about the maintenance during the use of this product.

■ Problems

- The alarm lamp on the OCP or on the MCP flashes ON and OFF.
- "TEMP!!" or "FAN!!" appears on the viewfinder screen.

■ Questions

- How to reset the settings to default (Return to the factory settings)

■ Maintenance

- Cleaning the camera connectors
- Resetting the breaker

6.1 Alarm Lamp on the OCP or MCP Flashes ON and OFF

The BS is equipped with a self diagnostic function which monitors whether the BS and camera are running normal. As soon as the BS main power switch is turned ON, the self diagnostic function starts running, and always runs during operation. If the BS or camera becomes abnormal, the diagnostic function immediately detects the abnormality, and the ALARM indicator on the OCP or MCP flashes ON and OFF. Furthermore, the self diagnostic information screen appears on the PM, so that you can locate the trouble point.

Note:

Even if the ALARM indicator does not flash, you can check whether BS and camera are running normal by pressing the PM IND/PAGE button on the OCP or on the MCP to display the self diagnostic screen on the PM.

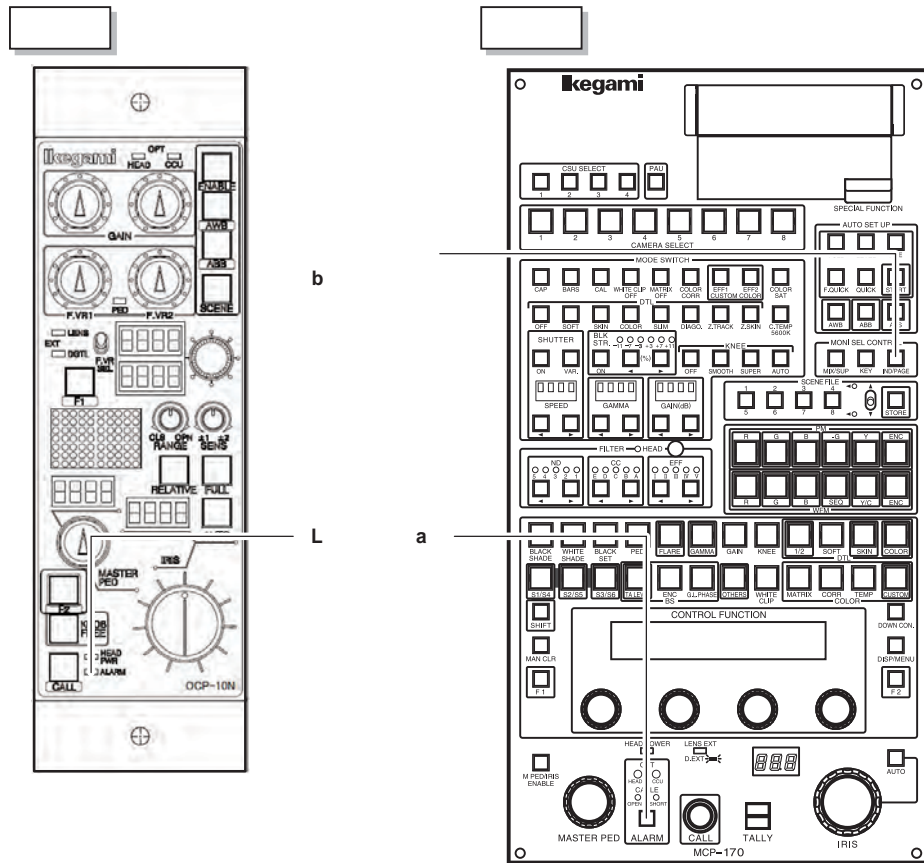

6

TROUBLE SHOOTING and MAINTENANCE

For the list of self diagnostic information of BSF-300, refer to the relevant operation manual. Perform the appropriate action referring to the list.

6.2 "TEMP!!" or "FAN!!" Appears on the VF Screen

When the temperature inside the camera increases abnormally, a warning indicating an abnormal temperature rise flashes on the viewfinder screen.

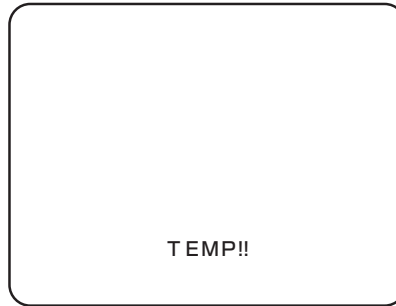

Status	Cause	Action
TEMP!! flashing	The camera is exposed to direct sunlight for many hours.	Put a sunshade cover on the camera to avoid direct sunlight.
	The camera is used near some heating appliance.	Move the position of the camera or heating appliance.

If a fan stops due to some failure, a warning indicating an irregular fan stop flashes on the viewfinder screen.

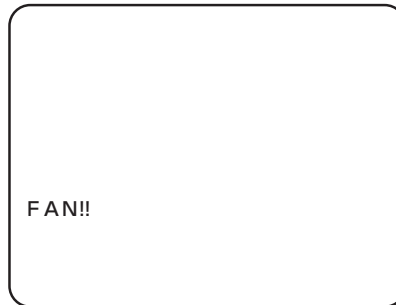

Status	Cause	Action
FAN!! flashing	Fan stops.	Inspect the fan for any problem.

Note:

To prevent temperature increase inside the camera, cooling fans are provided at the top of the camera and fiber adaptor.
For how to check which fan stops, refer to "5. CAMERA SETTINGS and ADJUSTMENT [Menu Configuration and content]" (P81).

6.3 Initializing the Settings of this Product

The following two cases are available for initializing the setting of this product.

1. Initializes the camera back to the user setting (ENGINEER SET FILE).
This initializes the camera back to the state set by user engineer in advance in response to the environment and the shooting conditions.
2. Initializes the camera back to the initial factory setting (FACTORY SET FILE)
This initializes the camera back to the initial factory setting.

To change the settings, select "PRESET FILE LOAD" on MENU (3/4), then "FILE SELECT" and "LOAD START."
The following explains the set values, descriptions, and setting procedures.

Set Value		Description
FILE SELECT	ENGINEER (default)	Initializes the state back to the user setting.
	FACTORY	Initializes the state back to the initial factory setting.
LOAD START	READY (default)	The state before initialization
	START	Starts initialization.
	CANCEL	Cancels initialization.

- 1 On MENU (3/4), turn the rotary pulse switch to position the cursor on "PRESET FILE LOAD", and press the SET button.

The submenu is displayed.

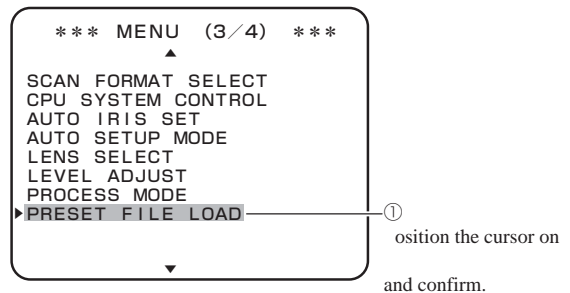

- 2 Turn the rotary pulse switch to position the cursor on "FILE SELECT", and press the SET button.

The cursor moves to the mode selection column.

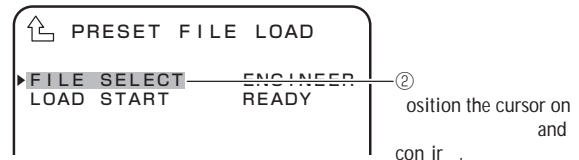

- 3 Turn the rotary pulse switch to select the value to be set, and press the SET button.

The value is confirmed.

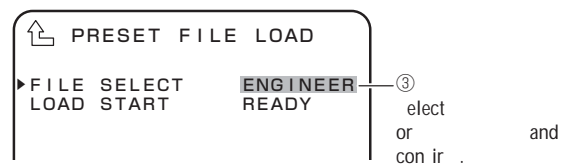

- 4 Press the SET button when the cursor automatically moves to "LOAD START".

The cursor moves to the mode selection column and its display changes from "READY" to "START".

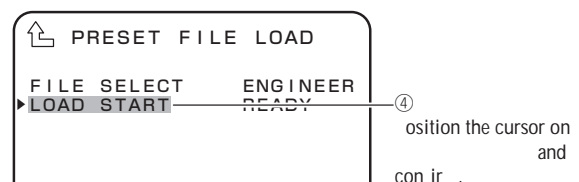

5 Turn the rotary pulse switch to select the set value, and press the SET button.

The value is confirmed.

- Selecting "CANCEL" cancels the setting and terminates "PRESET FILE LOAD".
 - Selecting "START" displays "PUSH SET -> START" at the bottom of the screen.
- Go to Step 6 when selecting "START".

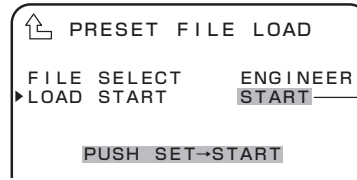

⑤
 Select the set value and confirm.
 Selecting displays a message at the bottom of the screen.

6 Press the SET button.

Initialization starts.

When the file load is completed, "COMPLETED" appears on the screen. Then, "CAMERA RESTART" blinks for about three seconds. After that, the camera restarts and the initialization is completed with the file selected in "FILE SELECT".

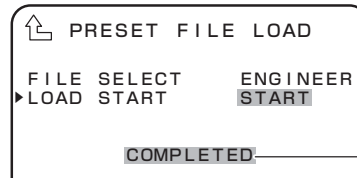

⑥
 Message is displayed at the bottom of the screen.

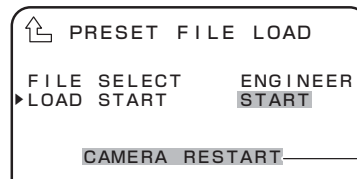

⑥
 Message is displayed at the bottom of the screen.

6.4 Cleaning Camera Connectors

The fiber cable connecting the camera and the BS transmits optical signals through 10 μ m core glass fibers. If Ferrules, which secure glass fibers, are dirty or have dust on them, transmission loss (optical signal attenuation) occurs. If Ferrules are extremely dirty, optical signals are interrupted and the fiber cable may not work properly. Regular cleaning of Ferrules is suggested if the camera connector is frequently removed and inserted. The figures below show the shape of the camera connector joint section, and how to clean the Ferrules:

● Camera Connector Joint Section

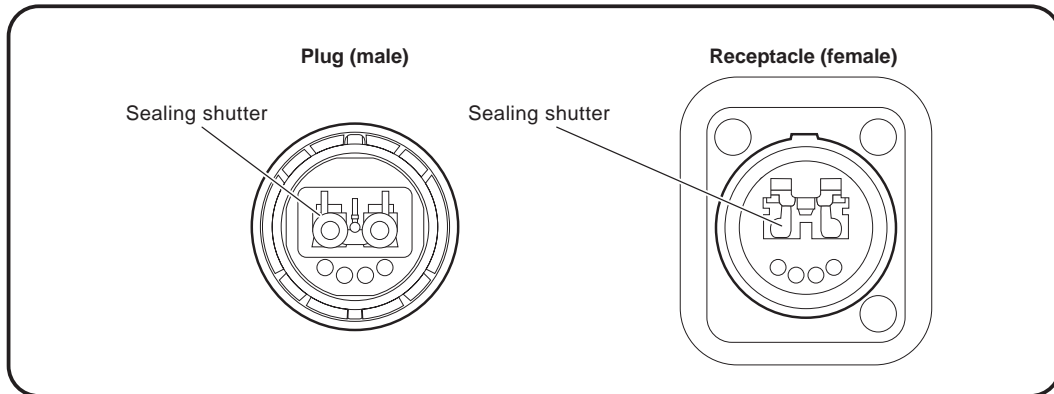

● Male and Female Camera Connectors

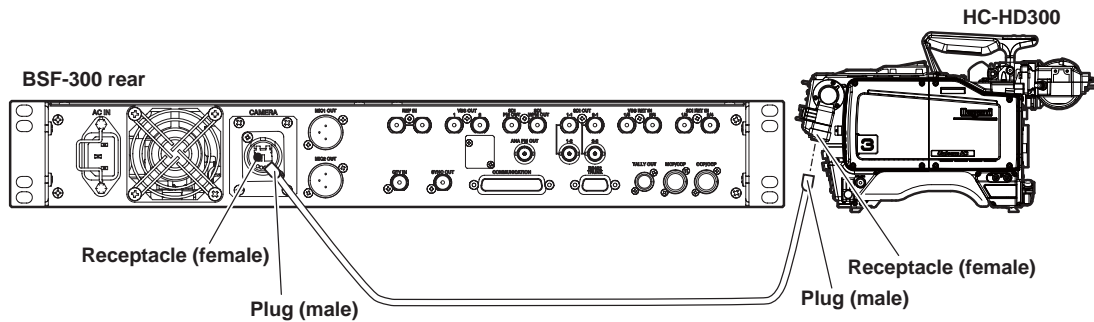

■ Cleaning the plug (male)

Clean the four sections: receptacle (female) on the camera head, receptacle (female) on the BS, and plugs (male) on both ends of the fiber cable.

The following explains how to clean Ferrules using a Neutrik-opticalCON fiber cable plug (male) as an example.

- 1 Pull the bushing in the direction of arrow ①, and simultaneously pull the connector housing (cable side) while turning it in the direction of arrow ② to remove the connector housing.

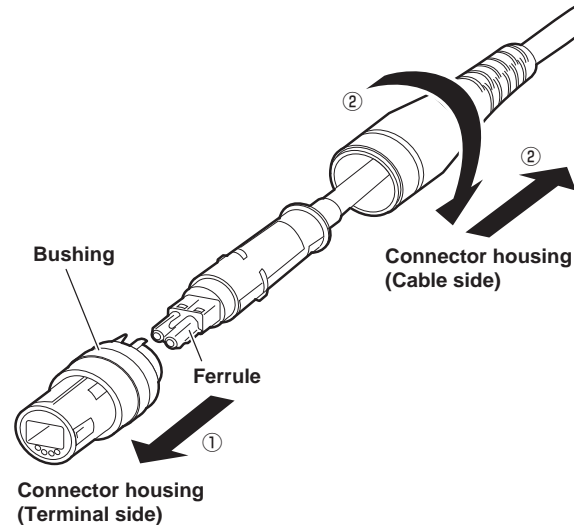

- 2 Wipe the Ferrule with a cotton swab dampened with alcohol.

CAUTION:

- When you wipe the Ferrule, move the cotton swab straight in a way in which you brush the dust off the Ferrule. Do not wipe back and forth or in a circle. Doing so may spread the dirt instead of removing it.
- Do not carelessly blow your breath on the Ferrule.

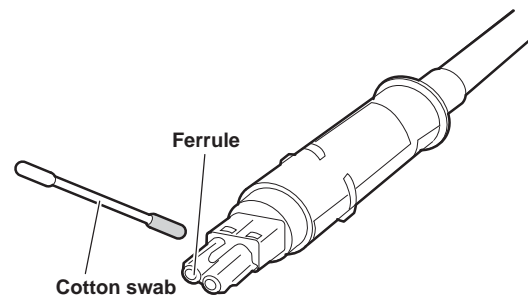

- 3 After wiping the Ferrule with alcohol, wipe the Ferrule with a dry cotton swab.

- 4 Make sure that the dirt is removed.

Use a loupe to examine the Ferrule.

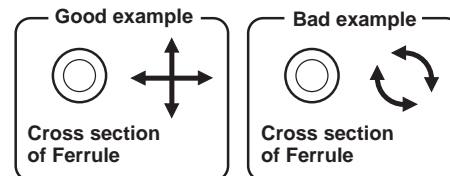

- 5 Make sure the ferrule is clean. Then, fit the connector housing (terminal side) and the cable guide. Insert the connector housing (cable side) while turning it in the direction of arrow ③.

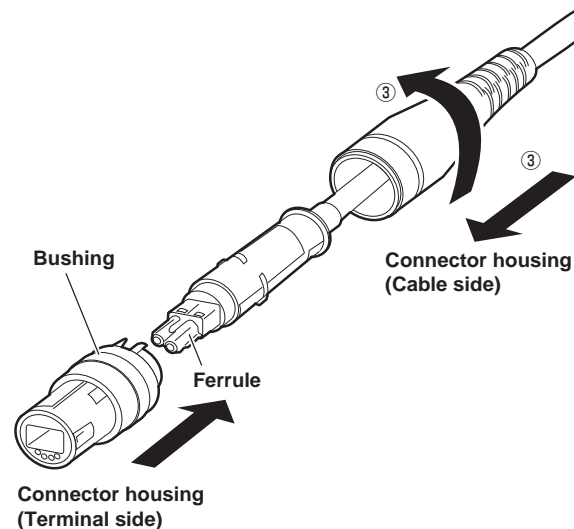

■ **Cleaning the receptacle (female)**

The following describes the cleaning method of a female pin.

CAUTION:

When you clean a female pin, use NEUTRIK cleaner FOCD-DC125.

- 1** Remove the cap of cleaner, and push the insert of pin to open the shutter.
- 2** Insert the cleaner until you hear "click." Repeat this action several times depending on a cleaning condition.
- 3** After finishing the cleaning, pull out the cleaner.

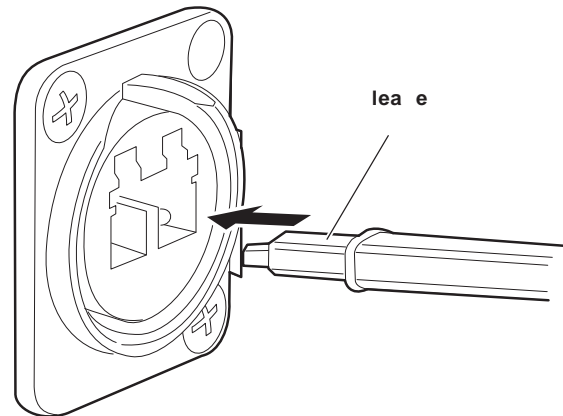

6.5 Reset the Breaker

If power is not being supplied to the camera even though the power is on and peripherals are connected correctly, it might mean that the power has been cut off by the breaker. In this case, reset the breaker as follows:

- 1** Check that the camera's POWER switch is OFF.
- 2** Push in the breaker on the left side of the camera.

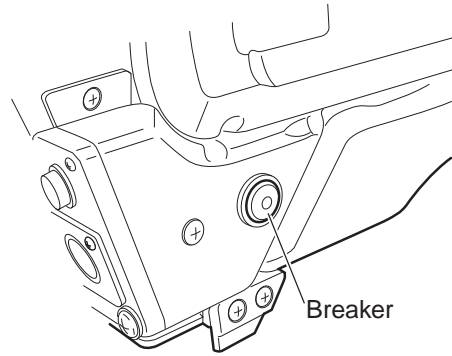

6.6 Sensor defect correction

Some defective pixels on the sensor may occur during operation. In that case, perform the defective pixel correction (DPC: Defective Pixel Correct) of CMOS sensor. This is effective for small defective pixel (singular pixel). The defective pixel correction is performed every time that auto black balance is performed. The auto black balance can be performed from camera and from OCP or MCP. The following describes a procedure to perform auto black balance from OCP.

- 1** Press ABB button on the operation control panel.

Note:

If there is a large defective pixel that cannot be removed by performing ABB, operate "AUTO DPC" in the engineering menu to perform defective pixel correction.

SPECIFICATIONS



7.1 HC-HD300 Specifications

■ Ratings

	Item	Rating				Remarks
1	Scanning system	1080i/59.94, 720p/59.94 1080i/50, 720p/50				Y:Pb:Pr 4:2:2
2	Image sensor	1/3 type MOS sensor × 3				Total pixels 2.5M
3	Effective number of pixels	1920 (H)×1080 (V)				
4	Sensitivity	F10 1080i / 59.94 F11 1080i/50 (Calculated value)				2000LX reflection rate 89.9% The sensitivity is defined as 1080i/59.94, and from this value, 1080i/50 is calculated.
5	Optical system	1/3 type R, G, B prism				
6	Lens mount	1/3 type bayonet mount				
7	Optical filter		1	2	3	4
		ND	100%	25%	6.2%	1.6%
8	Electric color conversion		A	B	C	D
		ECC	3200K	4300K	6300K	8000K
9	Sampling frequency	74.25 MHz/1.001 or 74.25 MHz				
10	VF	2-inch color VFL200HD [1080i 59.94 / 50]				
11	Power source voltage	DC+11 to +16V				
12	Ambient temperature	Operation temperature: -20°C to +45°C Storage temperature : -30°C to +60°C				
13	Ambient humidity	30% to 90%				No condensation.
14	EMI	FCC Class A				
15	External dimensions	Approx. W138.5×H270×D337				Not including projections.
16	Weight	Camera head + Fiber adapter : 4.3 kg				FA-300
		2-inch : 670 g				VFL-200HD
		7-inch : 1.0 kg				VFL-P700 (w/o Attachment plate)

■ Performance

	Item	Rating	Remarks
1	S/N ratio	58 dB (typ.) 1080i/59.94	Defined only in 1080i / 59.94. *1080i / 50,720p / 59.94 / 50 In is not specified.
2	Degree of modulation	55 % (typ.) at f2.8	Defined only in 1080i / 59.94. *1080i / 50,720p / 59.94 / 50 In is not specified.
3	Limiting resolution	1000 TVL (typ.)	Defined only in 1080i / 59.94. *1080i / 50,720p / 59.94 / 50 In is not specified.
4	Registration error	0.02 % or less	Not including lens distortion.
5	Contour correction	Horizontal boost frequency 13 MHz - 22 MHz	
6	GAIN	-6, -3, 0, +3, +6, +9, +12, +18dB	
7	GAMMA	OFF, 0.35, 0.4, 0.45	
8	Electronic shutter	1/100, 1/120, 1/250, 1/500, 1/1000, 1/2000	
9	Power consumption	HEAD : 13W	
		FA : 10W	
		2-inch VF : 4.1W	

■ Output signals (FA-300)

	Item	Rating	Remarks
1	Main line video signal	Y,Pb,Pr 4:2:2 digital serial (optical connector) Y,Pb,Pr 4:2:2 digital serial (75Ω BNC)	BTA S-004B compliant
2	Monitor video signal	RET image HD SDI 4:1:1 or VF HD SDI 4:2:2	Select with MENU
3	Analog signal	HD Y or NTSC/PAL VBS output (MON output terminal) NTSC/PAL VBS output (AUX OUT terminal)	Possible to select Q-TV output with MENU.
4	Q-TV	Analog video signal (75Ω BNC connector)	
5	Intercom signal	0 dBs 2 channels (XLR type or 110 type)	PROD, ENG

■ Input signals (FA-300)

	Item	Rating	Remarks
1	Return video signal	None	
2	External SYNC signal	SYNC 0.6Vp-p±6dB	BB/PS signal
3	Audio signal	-60 to +4dB (variable)/-20dB (fixed)	600Ω balance 2 channels
4	Intercom signal	2 channels (XLR type or 110 type)	ENG, PROD
5	External HD-SDI input signal	None	

■ Camera cables

	Item	Rating	Remarks
1	Standard cable	2SM - 9.2 - 37.5	
2	Studio-use cable	2SM - 16 - 37.5	
3	Cable configuration	Two single-mode type quartz fiber optic cables 4 power cables 2 control cables	HEAD-->BS, BS-->HEAD (one cable for each)
4	Power cables	37.5Ω/Km per cable	
5	Control cables	113Ω/Km per cable	

■ Applicable standards

Safety Standards : CE / FCC

■ Use conditions

Electrical environment : Usually a short life (Except electric field strength, magnetic field strength, etc.)

7.2 External Dimensions Diagram

■ Right View

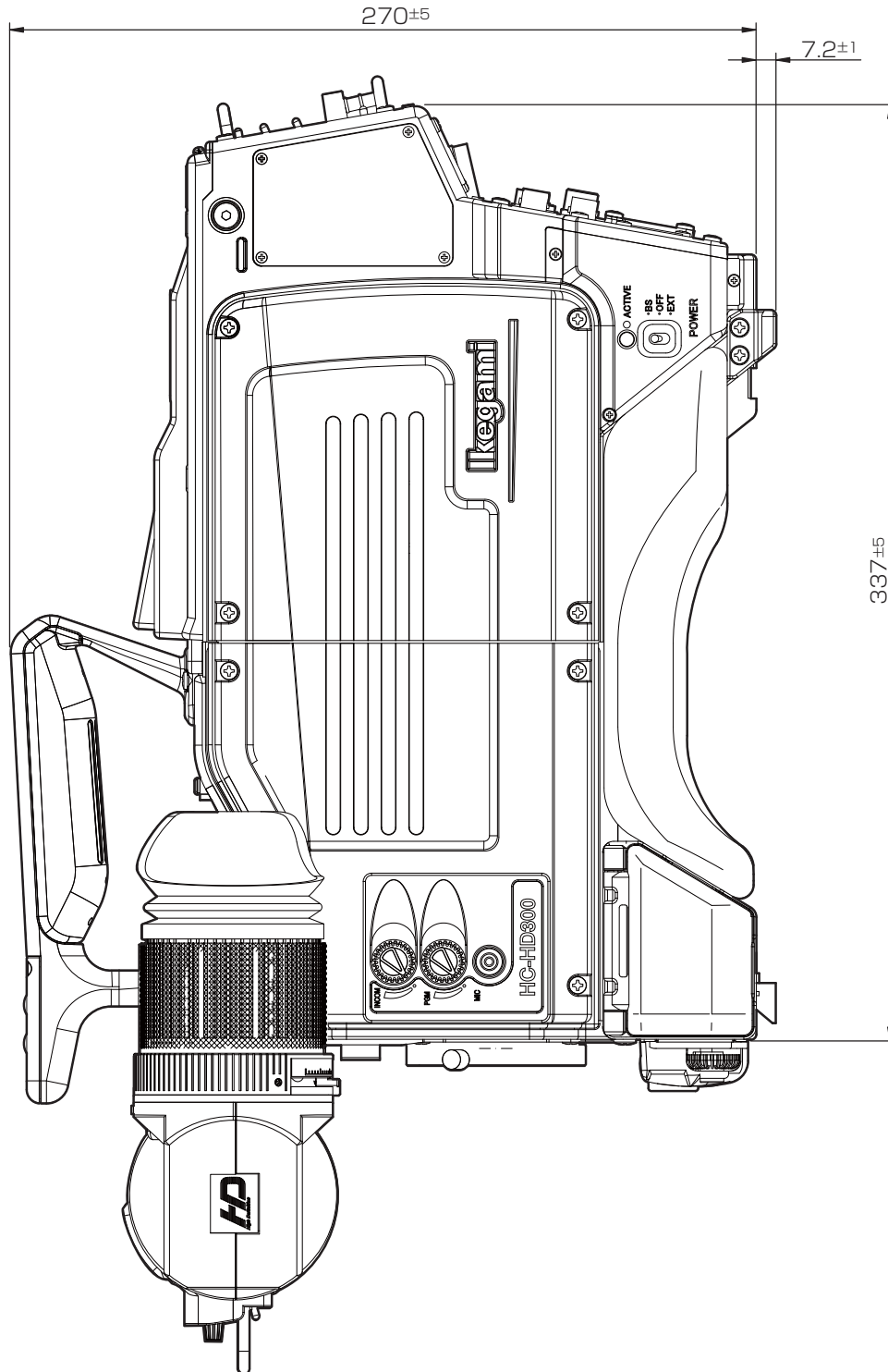

■ Left View

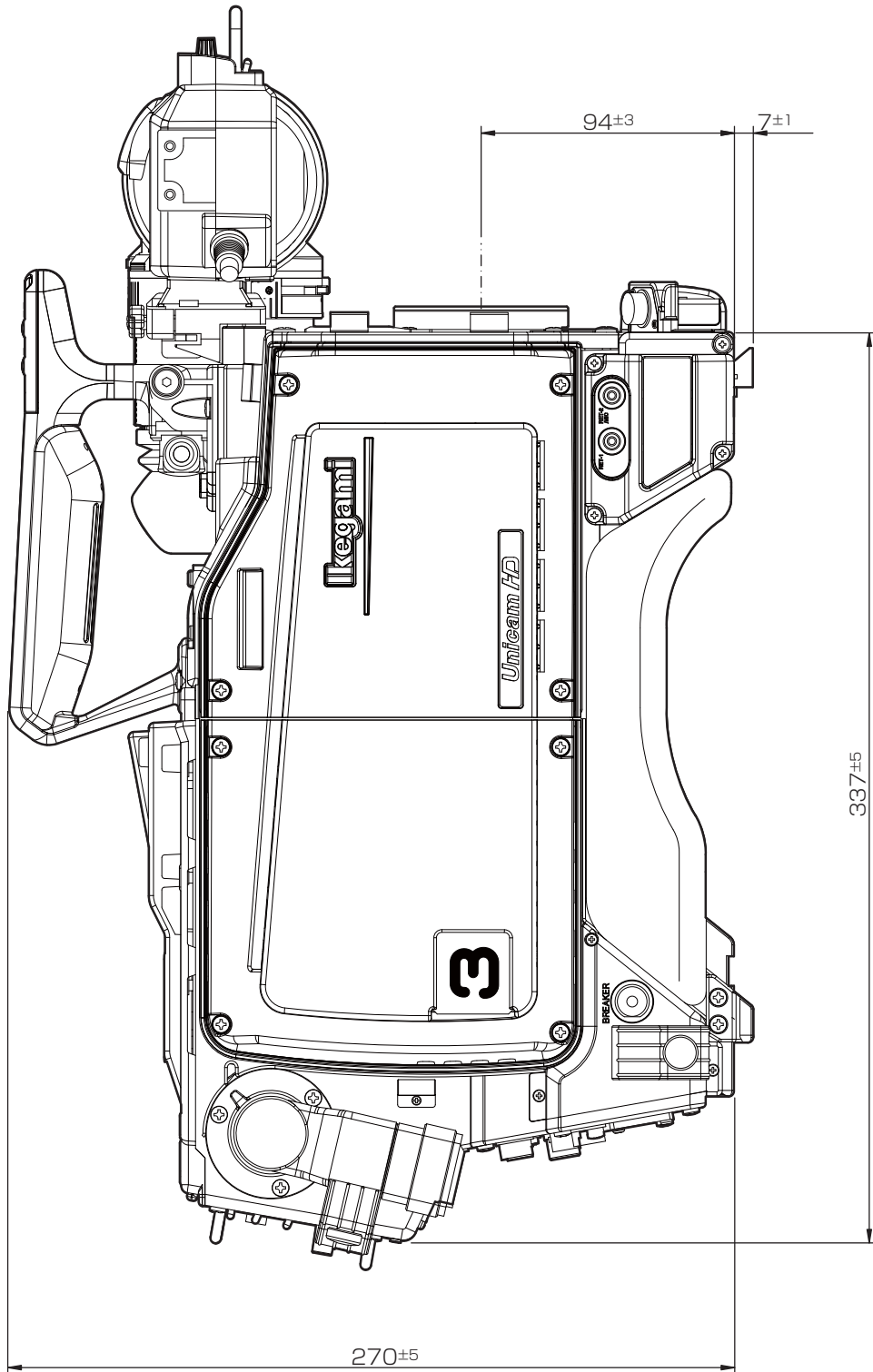

■ Front View

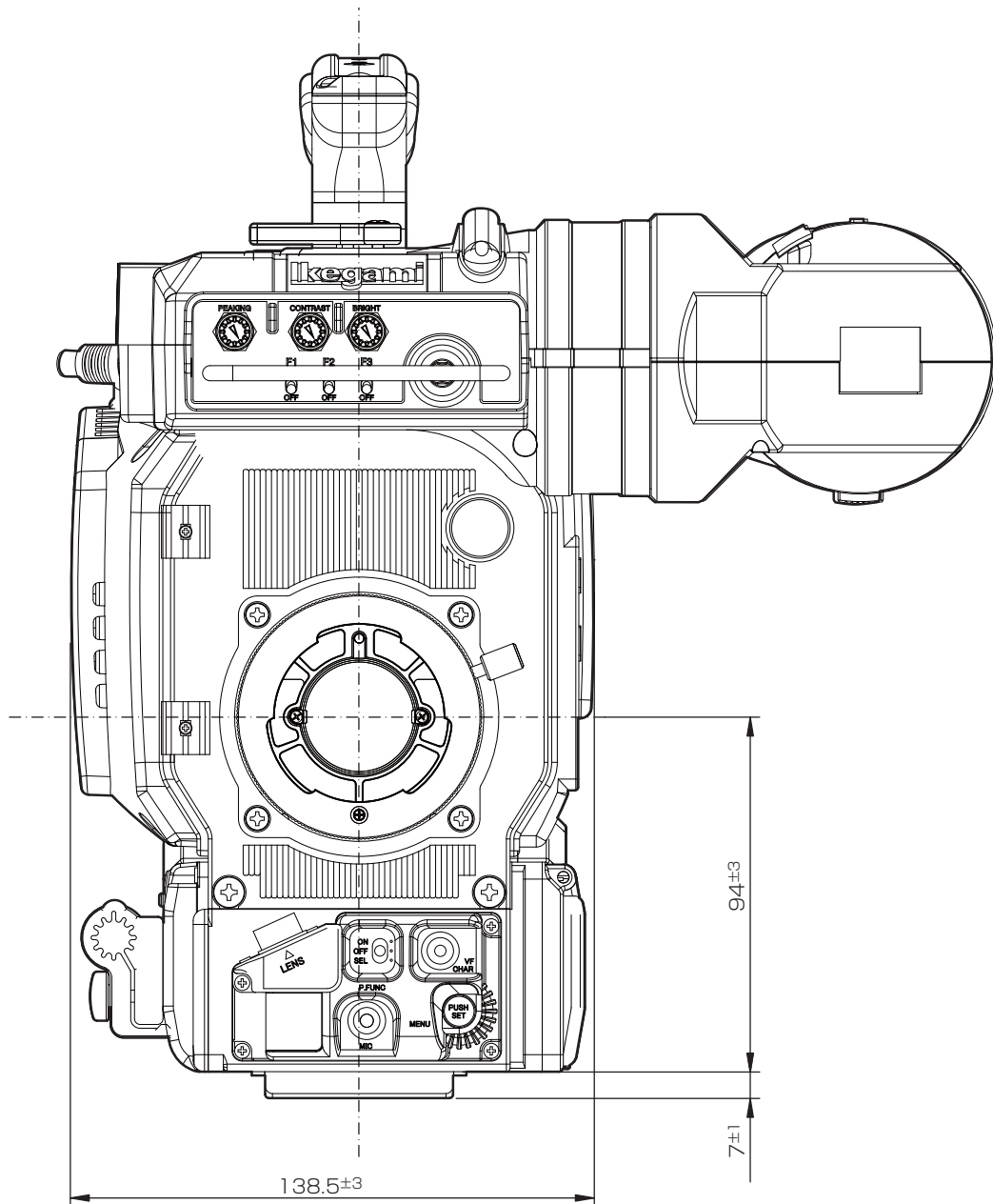

7

SPECIFICATIONS

■ Rear View

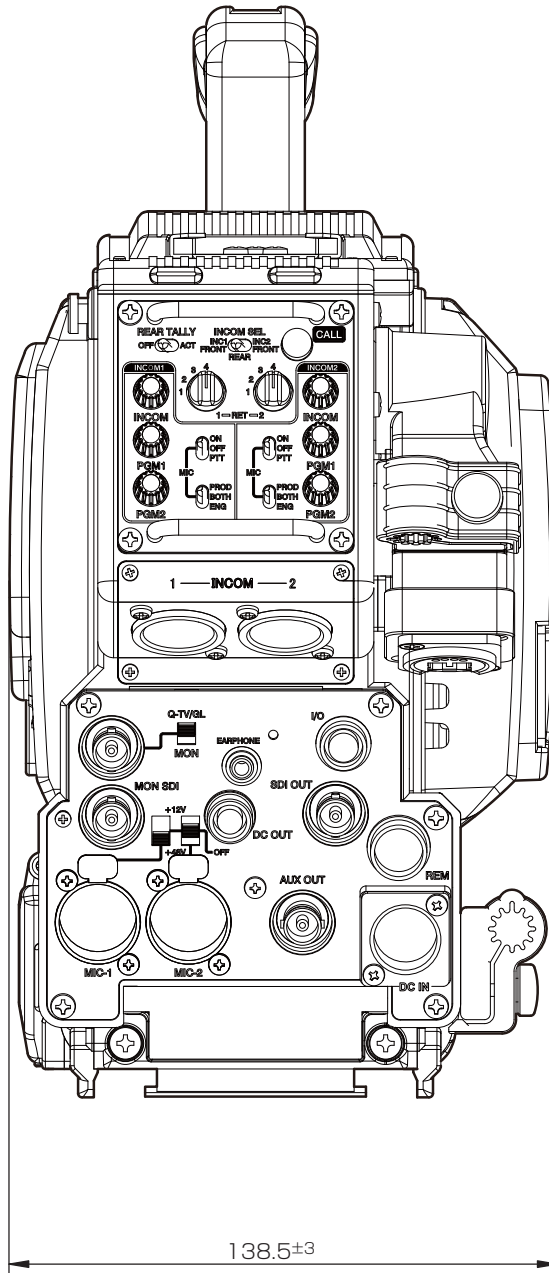

7.3 External Connections

■ Lens Connector

Used to connect each type of lens. The connector pin assignment differs among camera lens mount types.

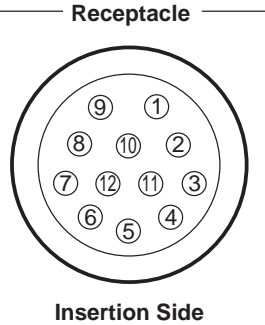

Camera head side : HR10A-10R-12SC

Cable side : HR10A-10P-12PC (12 pin male plug)

[BTA Mount]

Pin No.	Name	Function	I/O	External Interface
①	RET ON	RETURN VIDEO ON/OFF signal RETURN ON : 0.5V or less, Zout = 10 MΩ or more RETURN OFF : OPEN, Zout = 1.5 kΩ or less Zin = 100 kΩ± 5% (10 kΩ or more) Momentary action	IN	
②	VTR TRIG	VTR START/STOP signal VTR START : 0.5 V or less, Zout = 10 MΩ or more VTR STOP : OPEN, Zout = 1.5 kΩ or less Zin = 100 kΩ± 5% (10 kΩ or more) Momentary action	IN	
③	GND	Ground for lens	GND	
④	IRIS SERVO	IRIS forced-servo ON/OFF SERVO ON : + 5 V ± 0.5 V Zout = 10 kΩ or less SERVO OFF : 0.5 V or less Zout = 1.5 kΩ or less or 100 kΩ or more	OUT	
⑤	IRIS CONT	Lens IRIS control output F 2.8 : 6.2 V ± 0.05 V (6.2 V ± 0.1 V) F 16 : 3.4 V ± 0.05 V (3.4 V ± 0.1 V) CLOSE : 2.5 V ± 0.2 V (2.1 V to 2.9 V) Zout = 1 kΩ ± 10% (fixed)	OUT	
⑥	+12V LENS	DC+12V output for LENS Normal operating range : DC + 10 V to + 20 V (DC + 10 V to + 17 V)	OUT	
⑦	IRIS FOLLOW	Lens IRIS control output F 2.8 : 6.2 V ± 0.05 V (6.2 V ± 0.1 V) F 16 : 3.4 V ± 0.05 V (3.4 V ± 0.1 V) CLOSE : 2.5 V ± 0.2 V (2.1 V to 2.9 V) Zin = 100 kΩ ± 2% (100 kΩ or more)	IN	

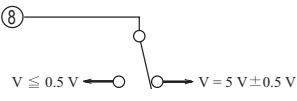
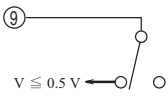
Pin No.	Name	Function	I/O	External Interface
⑧	IRIS REM/AUTO	IRIS REMOTE/AUTO switching REMOTE : + 5 V \pm 0.5 V Zout = 1 k Ω \pm 10% (10k Ω or less) AUTO : 0.5V or less Zout = 1.5 k Ω or less or 100k Ω or more Zin = 100 k Ω \pm 2% (100k Ω or less)	OUT	
⑨	EXT ANS	Input and output of ANSWER signal sent from an external system IN : + 0.5 V or less, Zout = 1.5 k Ω or less OUT : OPEN, Zout = 10 M Ω or more Zin = 100 k Ω \pm 5% (100k Ω or more)	IN OUT	
⑩	ZOOM FOLLOW	Lens zoom control output WIDE : 2.0 V \pm 0.05 V (2.0 V \pm 0.2 V) TELE : 7.0 V \pm 0.05 V (7.0 V \pm 0.2 V) Zin = 100 k Ω \pm 2% (10 k Ω or more) Zout = 1 k Ω \pm 10% (1 k Ω or less)	IN	
⑪	FOCUS FOLLOW	Lens focus control output Minimum distance : 2.0 V \pm 0.05 V (2.0 V \pm 0.2 V) Infinite distance : 7.0 V \pm 0.05 V (7.0 V \pm 0.2 V) Zin = 100 k Ω \pm 2% (20 k Ω or more) Zout = 1 k Ω \pm 10% (1 k Ω or less)	IN	
	LENS \rightarrow CAMERA	Serial data receive (LENS \rightarrow CAMERA) + 0.5 V CMOS level (VCC 5V \pm 0.25V)	IN	
⑫	CAMERA \rightarrow LENS	Serial data transmit (CAMERA \rightarrow LENS) + 0.5 V CMOS level (VCC 5V \pm 0.25V)	OUT	

Numbers within parentheses are standard values in the conventional SDTV system of 2/3-inch camera lens.

IN : camera \leftarrow lens

OUT : camera \rightarrow lens

VF Connector

Used to connect a 2-inch viewfinder.

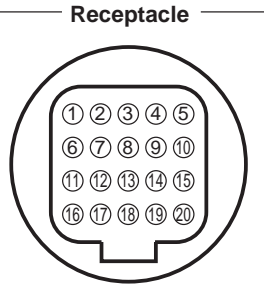

Insertion Side

Camera head side : HR12-14RA-20SC

Pin No.	Name	Function	I/O	External Interface
①	+ 12 V	DC +12V power supply	OUT	
②	+ 12 V	DC +12V power supply	OUT	
③	N.C	-----	—	
④	+12V RET (VF GND)	Ground for DC+12V power supply	RET	
⑤	+12V RET (VF GND)	Ground for DC+12V power supply	RET	
⑥	G/Y VF VIDEO	G/Y VF VIDEO output signal	OUT	
⑦	G/Y VF VIDEO RET	Ground for G/Y VF VIDEO output signal	RET	
⑧	VF M CLK	Reference clock pulse signal for serial data reproduction	OUT	
⑨	SP WR	Read pulse signal for serial-parallel data conversion	OUT	
⑩	VF SP DATA	Serial data signal for serial-parallel data conversion	OUT	
⑪	+12V RET	Ground for DC+12V power supply	RET	
⑫	ZEBRA ON	ZEBRA signal ON/OFF switching	IN	
⑬	ZOOM POSI	Zoom position control	OUT	
⑭	(+9V)	-----	—	
⑮	COLOR ON	Color VF control	IN	
⑯	B VF VIDEO	B VF VIDEO output signal	OUT	
⑰	B VF VIDEO RET	Ground for B VF VIDEO output signal	RET	
⑱	R VF VIDEO	R VF VIDEO output signal	OUT	
⑲	R VF VIDEO RET	Ground for R VF VIDEO output signal	RET	
⑳	+12V RET	Ground for DC+12V power supply	RET	

■ CAMERA Connector

Used to connect the camera to its BS.

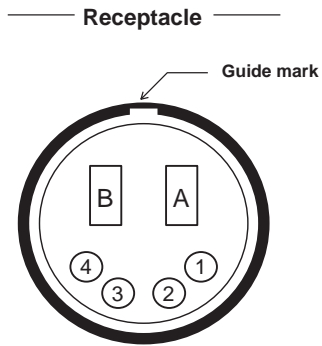

Camera head side : N02-4FDW-1-AS

Insertion Side

Pin No.	Name	Function	I/O	External Interface
A	OPT B - H	Optical contact B camera		
B	OPT H - B	Optical contact camera B		
①	DC+50V RET	Power supplied from the B		
②	DATA+	Control signal		
③	DATA-	Control signal		
④	DC+50V	Power supplied from the B		

■ PROD INCOM Connector and ENG INCOM Connector

Used to connect an intercom headset.

Each headset type has each connector shape.

You can use the carbon type of intercom microphone or the dynamic type of that.

For switch between the carbon type and the dynamic type, use menu display. Refer to "5. CAMERA SETTINGS and ADJUSTMENT [Menu Configuration and content]" (P81).

[7-pin Type]

Receptacle

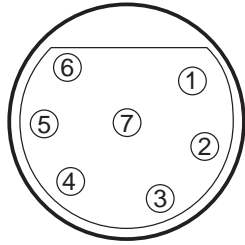

Insertion Side

Camera head side : NC7FD-LX-B (Neutrik)

Cable side : XLR-7-12C

Pin No.	Name	Function	I/O	External Interface
①	LISTEN L (C)	Shield for intercom receiver output	①	① → Receiver
②	LISTEN L (H)	Intercom receiver output		
③	TALK (C)	Shield for intercom microphone input	③	③ ← Intercom microphone
④	TALK (H)	Intercom microphone input		
⑤	COMM	MM Terminal		
⑥	LISTEN R (H)	Intercom receiver output	⑥	⑥ → Receiver
⑦	LISTEN R (C)	Shield for intercom receiver output	⑦	

[5-pin Type]

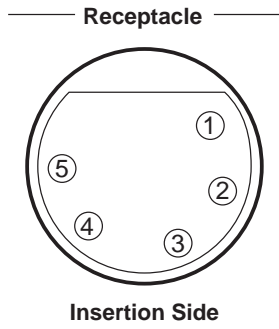

Camera head side : NC5FDL-1 (Neutrik)
Cable side : XLR-5-12C (5-pin male plug) or equivalent

Pin No.	Name	Function	I/O	External Interface
①	TALK (C)	Shield for intercom microphone input	GND	
②	TALK (H)	Intercom microphone input	IN	
③	SHIELD	Shield for output	GND	
④	LISTEN Lch (H)	output	OUT	
⑤	PGM Rch (H)	output	OUT	

[4-pin Type]

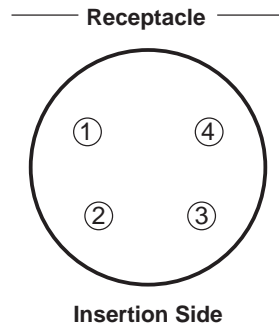

Camera head side : NC4MDL-1 (Neutrik)
Cable side : XLR-4-11C (4-pin female plug) or equivalent

Pin No.	Name	Function	I/O	External Interface
①	TALK (C)	Shield or intercom microphone input	GND	
②	TALK (H)	Intercom microphone input	IN	
③	LISTEN (C)	Shield or output	GND	
④	LISTEN (H)	output	OUT	

[3-pin Type]

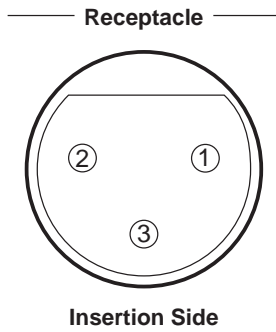

Camera head side : NC3FDL-1 (Neutrik)
Cable side : XLR-3-12C (3-pin male plug) or equivalent

Pin No.	Name	Function	I/O	External Interface
①	COMMON GND	Shield for intercom microphone	GND	
②	POWER	Speaker output to microphone	OUT	
③	TALK	Input to and output from intercom microphone	IN/ OUT	

[114B Jack]

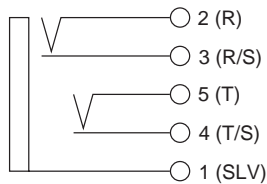

Camera head side : 114B (SWITCH CRAFT)
Cable side : 110 phone plug

Pin No.	Name	Function	I/O	External Interface
①	COMM	MM pin connect to sleeve of plug	GND	
②	LISTEN L (H)	Intercom receiver output connect to ring of plug	OUT	
③	LISTEN L (C)	Intercom receiver output connect to ring of plug	OUT	
④	TALK (C)	Intercom microphone input connect to tip of plug	IN	
⑤	TALK (H)	Intercom microphone input connect to tip of plug	IN	

■ MIC-1 Connector and MIC-2 Connector

Used to connect for input to a microphone. (600Ω balanced input)

Receptacle

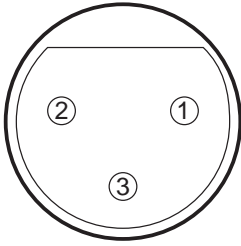

Insertion Side

Camera head side : HA16PRM-3SE (mounted on a board) (HRS)

Cable side : XLR-3-12C (3-pin male plug) or equivalent

Pin No.	Name	Function	I/O	External Interface
①	MIC (SHIELD)	MIC input shield	—	
②	MIC (HOT)	MIC (HOT) line 600Ω balanced input When AB power is supplied : DC 12V When +48 phantom power is supplied : DC 48V	IN	
③	MIC (COLD)	MIC (COLD) line 600Ω balanced input When AB power is supplied : DC 0V When +48 phantom power is supplied : DC 48V	IN	

■ DC-IN Connector

Used to connect external power supply.

Receptacle

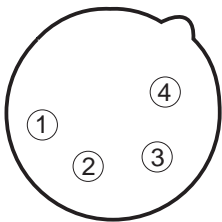

Insertion Side

Camera head side : HA16RX-4P (SW1)

Cable side : XLR-4-11C (4-pin female plug) or equivalent

Pin No.	Name	Function	I/O	External Interface
①	+12 V RET	+12V input RET	IN	
②	NC	-----	—	
③	NC	-----	—	
④	+12 V IN	+12V input (11V to 16V)	IN	

■ REMOTE Connector

Used to connect an external remote controller.

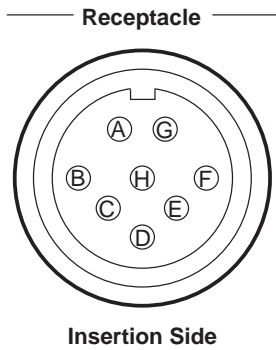

Camera head side : PRC 05-R8F

Cable side : PRC 05-PB8M (8-pin male plug)

Pin No.	Name	Function	I/O	External Interface
A	HED (+)	igital data output from camera to remote controller		
B	HED (-)	igital data output from camera to remote controller		
C	HEC (+)	igital data output from remote controller to camera		
D	HEC (-)	igital data output from remote controller to camera		
E	+ 12 V (REM)	power supply to remote controller		
F	+ 12 V RET (REM)	ground for power supply		
G	REM LISTEN	intercom output from remote controller		
H	REM TALK	intercom input to remote controller		

I/O Connector

Receptacle

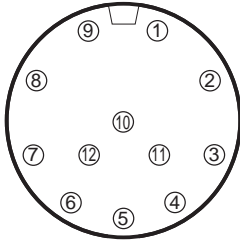

Insertion Side

Camera head side : HR10A-10R-12SC
Cable side : HR10A-10P-12PC

Pin No.	Name	Function	I/O	External Interface
①	PC RXD (+)	Digital data input (+) from remote controller to camera	IN	
②	PC RXD (-)	Digital data input (-) from remote controller to camera	IN	
③	PC TXD (+)	Digital data output (+) from camera to remote controller	OUT	
④	PC TXD (-)	Digital data output (-) from camera to remote controller	OUT	
⑤	+ 12 V RET	Ground for DC +12V power supply	RET	
⑥	+ 12 V	DC +12V power supply to remote controller	OUT	
⑦	R TALLY	R TALLY ON/OFF signal	OUT	
⑧	G TALLY	G TALLY ON/OFF signal	OUT	
⑨	RET - 1	RET-1 ON/OFF signal	IN	
⑩	RET - 2	RET-2 ON/OFF signal	IN	
⑪	-----	-----	—	
⑫	-----	-----	—	

DC OUT Connector

Receptacle

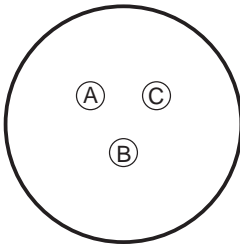

Insertion Side

Camera head side : PRC05-R3F
Cable side : PRC05-P3M

Pin No.	Name	Function	I/O	External Interface
Ⓐ	+ 12 V	DC + 12V power supply	OUT	
Ⓑ	+ 12 V RET	Ground for DC + 12V power supply	RET	
Ⓒ	N . C	-----	—	

7.4 Scene File

■ Save condition of a HC-HD300 scene file

Item	Save Data
PED	Adjusted value
MASTER PED	Adjusted value
BLACK STRECH	OFF/-11% to +11%
FLARE	ON/OFF, Adjusted value
MASTER FLARE	Adjusted value
MASTER BLACK GAMMA	ON/OFF, Adjusted value
GAMMA	ON/OFF, Adjusted value
MASTER GAMMA	Adjusted value
GAMMA TYPE	OFF/0.35/0.40/0.45
GAIN	Adjusted value
MASTER GAIN	Adjusted value
STEP GAIN	-6dB to +18dB
WHITE SHADING	ON/OFF, Adjusted value
MANUAL KNEE	ON/OFF, Adjusted value
SMOOTH KNEE	OFF/TYPE1 to TYPE3
AUTO KNEE	ON/OFF, Adjusted value
SUPER KNEE	OFF/LOW/MID/HIGH
WHITE CLIP	ON/OFF, Adjusted value
VARIABLE C.TMEP	ON/OFF, Adjusted value
ECC FILTER	3200K/4300K/6300K/8200K
ND FILTER	ND1 to ND4
DTL	ON/OFF, Adjusted value
Z.Track DTL	ON/OFF, Adjusted value
SOFT DTL	ON/OFF, Adjusted value
SKIN DTL	ON/OFF, Adjusted value
FINE	Adjusted value
COLOR DTL	ON/OFF, Adjusted value
HI-LIGHT DTL	ON/OFF, Adjusted value
MATRIX	OFF/MTX1 to MTX3, Adjusted value
COLOR SAT	ON/OFF, Adjusted value
COLOR CORRECT	ON/OFF, Adjusted value
COLOR HUE	ON/OFF, Adjusted value
PRESET SHUTTER	ON/OFF, Adjusted value
VARIABLE SHUTTER	ON/OFF, Adjusted value
SUPER V	ON/OFF

CHANGING INFORMATION

This chapter contains the revision information of user-specific specification or design change requested by users or any changes done by Ikegami.

Read by comparing this information with the main part of the operation manual.

HC-HD300

HIGH DEFINITION CAMERA SYSTEM OPERATION MANUAL

1st Edition : December 2014
Published in Utsunomiya Factory of
Ikegami Tsushinki Co., Ltd.

© December 2014 Ikegami Tsushinki Co., Ltd.

- All rights reserved. Reproduction or duplication, without permission of Ikegami Tsushinki Co., Ltd. of editorial or pictorial content in whole or in part, in any manner, is prohibited.
- Specifications and design are subject to change without prior notice.

Ikegami

e a L

e a a a a
e a a a
al e e a
L e a e

e a le e e a e e e
e e e a
al e ee e a e e e a
L e a

e a le e b
e a a e e a
e a
al e a e
L e a e

e a le e b
l e la l e
b a e le e
e a
al e al e a ale e a

e a le a a eL
a e e al a e l
a e
e a
L e a

e